

# Screw Jack Systems





ZIMM

ZIMM  
Z5-14F-150-105







**ZIMM**  
Made in Austria/EU  
www.zimm.com

Type: ZE 25 SW-AGT  
Date: 25AN 4-02  
T<sub>max</sub>/n<sub>max</sub>: 1500/6000 rpm  
Serial No.: L-292-807308

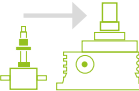
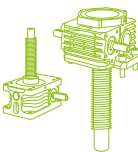

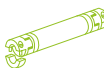
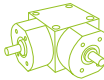
# TABLE OF CONTENTS

## ZIMM Product Catalogue 2021

	<b>Overview</b>	<b>1</b>
	Europe's leading manufacturer   The top 5 arguments for ZIMM	4
	Digitale Services / Online CAD Product configurator	6
	Key benefits - ZIMM Screw jacks features	8
	ZIMM Screw jacks product range	10
	ZIMM modular system - faster to the complete lifting system	12
	<b>Screw Jack</b>	<b>2</b>
	Trapezoidal screw jacks (Tr), S + R-Version, 5 - 1000 kN	14
	Tr Security & inspection (SIFA)	44
	Ball screw jacks (KGT), S-Version, 5 - 1000 kN	50
	Ball screw jacks (KGT), R-Version, 5 - 1000 kN	60
	High-performance gearbox ZE-H, 35 - 200 kN	70
	GSZ-Series   Cubic screw jacks Tr, S + R-Version, 2,5 - 150 kN	72
	GSZ-Series   Cubic screw jacks KGT, S + R-Version, 5 - 150 kN	90
 	<b>Accessories</b>	<b>3</b>
	S-Version   Add-on components	98
	R-Version   Nuts	106
	S + R-Version   Bellows, spiral springs, pivoting	110
	S + R   Motor flange MF (Size 2 - 1000 kN)	117
	S + R   Three-phase AC motors	120
	<b>Connection technology</b>	<b>4</b>
	Connecting shafts VWZ 30 - 100	126
	Pedestal bearing STL, shaft extension WZ	130
	Couplings KUZ & KUZ-KK	132
	<b>Bevel gearboxes</b>	<b>5</b>
	KSZ-H, 5 -150	136
	Motor flange combinations	140
  	<b>Technical information</b>	<b>6</b>
	Lubrication, lubricants for spindle and gearbox	144
	Enquiries, checklists	146
	Design advice, design, attachments	152
	Permissible loads, permissible loads pivoting	158
	Critical buckling force, critical whirling speed	162
	Drive torque, length calculation	164
	Operational reliability and safety, ordering code	170
	Temperature, clean room, food industry...	173
	<b>About ZIMM</b>	<b>7</b>
	Copyright & directions	180
	General terms and conditions	181



# EUROPE'S LEADING MANUFACTURER

## ZIMM Company

**By choosing ZIMM, you are not only choosing an efficient partner, but also the number one in Europe.**

There are five decades of experience within each ZIMM screw jack. Since 1991 we have been systematically improving our know-how regarding our ZIMM modular system, in order to meet your requirements as a customer faster, more precisely, and more reliably than one may at first expect. ZIMM is delighted to constantly improve our gearboxes and thankful to continue our success. This has made ZIMM the market leader in screw jacks in Europe and a sought-after supplier worldwide. At ZIMM you receive solutions that have been proven again and again, and have therefore convinced well-known machine builders and industrial companies in countless industries to also choose ZIMM. As an owner-managed family company, it is our concern to supply you with the best tools in the industry, outstanding delivery reliability and last but not least, our own personal touch.

# THE TOP 5 ARGUMENTS FOR ZIMM

## 1

### Flawless design in half the time

- Massive time saving in design
- Most efficient configurator in the industry
- Complete systems with all drives and connections
- Assemble proven standard parts yourself
- Software prevents design errors
- Generate and download CAD in real time

## 2

### Most extensive modular system

- Proven standard customised components
- More than 7,000 useful combination options
- Complete lifting systems including drive motors
- Engineering service for special requirements

## 3

### Pioneering product design

- Continuous improvement and further development
- Harmonious design also for a visible installation
- Well thought-out details and product advantages
- Standardised interfaces and installation sizes

## 4

### Proven and tested quality

- From Europe's leading provider
- Standard anti-corrosion protection
- Comprehensive test, measurement and inspection systems
- ISO 9001: 2015 certified

## 5

### Reliable and fast delivery

- Order processing via website possible
- Flexibility and capacity for large quantities
- High delivery reliability
- Short delivery time

# DIGITAL SERVICES

## With tangible benefits - ZIMM Online configurator

ZIMM supports you with sophisticated digital tools during selection, construction and ordering.

The ZIMM product configurator accompanies you to your screw jack or lifting system easily, quickly and intuitively. Sophisticated plausibility checks in the background

prevent planning errors. Discover the simplicity and download the required CAD data for your next project with ease!

[www.zimm.com](http://www.zimm.com)



# TOUCH THE FUTURE

With the **ZIMM 3D & AR APP**



The ZE Evolution app makes the boundaries between planning and the real world disappear. Immerse yourself and get inspired by the 3D representation of a ZE lifting gear including all attachments.

Use the future-oriented possibilities to represent the gearbox in a real environment using augmented reality. Explore the product features in a digital constructed environment using virtual reality-mode of the app.

**Download the app to your smartphone or tablet via our website!**

[appszimm.com](http://appszimm.com)



# KEY BENEFITS

## for every use

**Screw jacks are a modern technology for precise lifting and positioning of components or loads. Numerous details and equipment make ZIMM drives the first choice.**

With their performance, accuracy and economy, screw jacks outperform hydraulic solutions in more and more applications. ZIMM screw jacks also shine with a number of features that they already have in the basic equipment ex works.

The most important advantages can be seen in the adjacent figure.

## ZIMM Screw jacks

- 1 Spindle with trapezoidal or ball thread**  
Depending on the requirements for economy, accuracy and speed
- 2 High performance gearing**  
Hardened and ground for outstanding durability and energy efficiency
- 3 Standardised flanges and attachments**  
In stock for commercially available engines
- 4 Corrosion protection ex works**  
Consistent basic protection as standard; further protection levels and desired colours possible
- 5 Integrated sliding swivel bearings**  
Matching bearing blocks, as standard
- 6 Sealed gear**  
Lubricated-for-life for high speeds and operating times
- 7 Lubrication without downtimes**  
Lubrication possible also during operation
- 8 Ready for all installation positions**  
With prepared holes for all types of installation; Installation upside down with nominal load



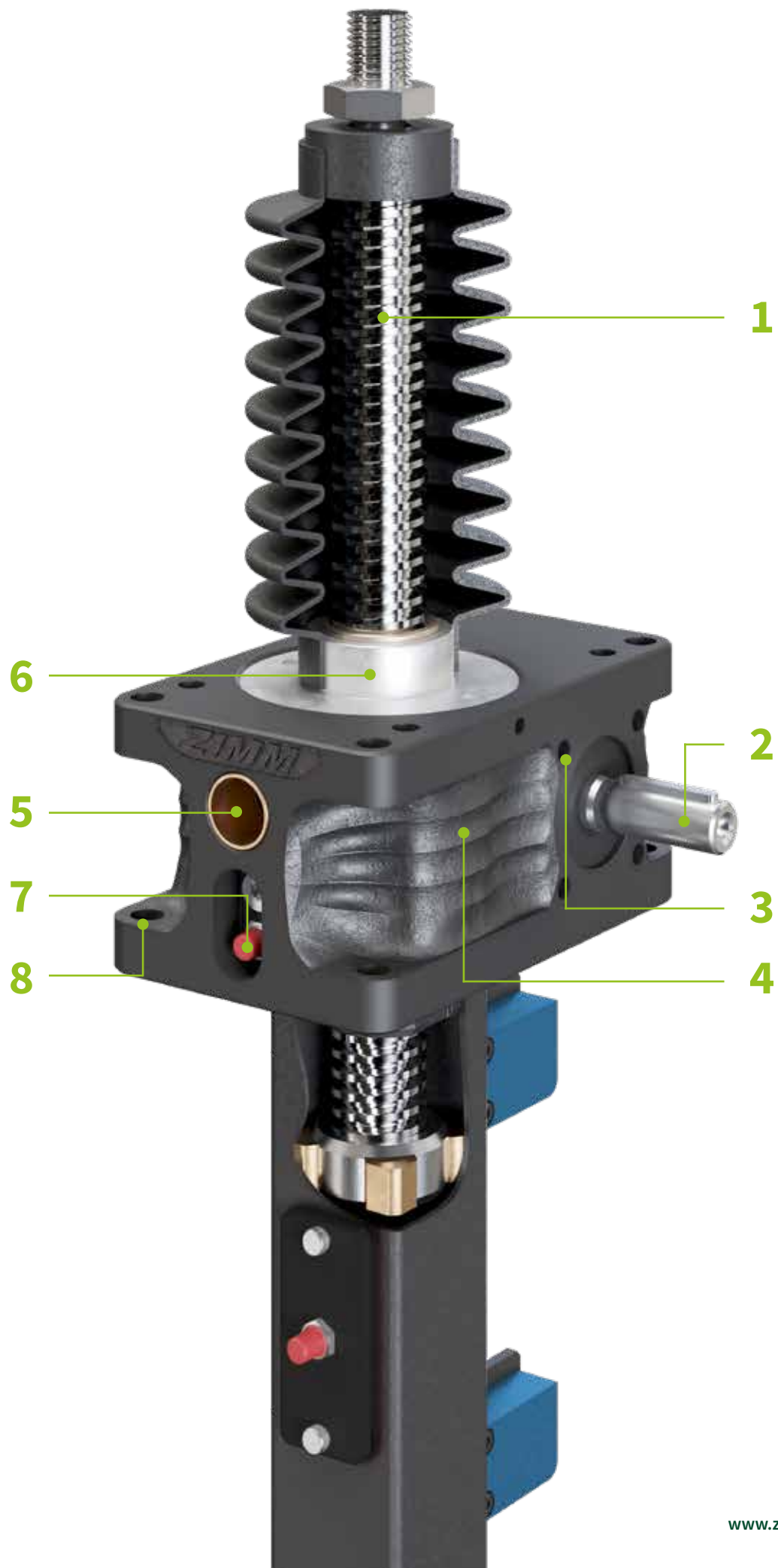

# OUR SCREW JACK PRODUCT RANGE

Sizes from 2,5 to 1000 kN

Series/Load	2,5 kN		5 kN		10 kN	25 kN	35 kN		50 kN	100 kN
<b>ZE Series</b>  <b>Newest technology</b> 100% compatible with the previous Z-Series. Proven and improved once again.										
<b>ZE-H Series</b>  <b>High-performance series</b> Highly dynamic requirements and Speeds up to 3000 min-1 in combination with ball screw.										
<b>Z-Series</b>  <b>Proven series</b> for large loads.										
<b>GSZ Series</b>  <b>Cubic series</b> Compatible with „SHZ“ and „MSZ“										
<b>S-translating screw</b> <b>R-rotating screw</b>	S	R	S	R	S + R Version	S + R Version	S	R	S + R Version	S + R Version
<b>Drive ratios</b>	4:1 16:1				6:1 24:1		7:1 28:1		7:1 28:1	9:1 36:1
<b>Housing material</b>	Aluminium						GGG		GGG	
<b>Tr</b> Trapezoidal screw	16x4		18x4		20x4	30x6	40x7		40x7 (50x8)	55x9
<b>SIFA Tr</b> Safety nut	-	16x4	-	18x4	20x4	30x6	40x7		40x7	55x9
<b>KGT</b> Ball screw	-	16x5 16x10		25x5 25x10 25x25 25x50	32x5 32x10 32x20 32x40	-	40x5 40x10 40x20 40x40		50x10 50x20 50x40 50x50	

# Catalog

## Icon description | Screw jack version

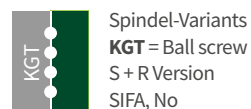
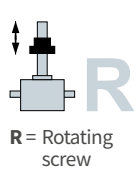
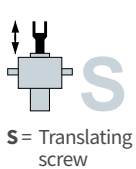

150 kN		200 kN		250 kN		350 kN		500 kN		750 kN		1000 kN	
S + R Version		S + R Version		S + R Version		S + R Version		S + R Version		S + R Version		S + R Version	
9:1 36:1		8:1 24:1				10,66:1 32:1						13,33:1 40:1	
GGG		GGG						GGG					
60x9		70x12		80x16		100x16		120x16		140x20		160x20	
60x9		-	70x12	80x16		100x16		120x16		140x20		160x20	
63x10 63x20 63x40 63x60		80x10 80x20 80x40 80x60				100x20 100x40 100x60 100x80		125x25 125x40 125x60 125x80		140x25 140x40 140x60 140x80		160x25 160x40 160x60 160x80	

# FASTER AND EASIER TO THE COMPLETE LIFTING SYSTEM

## ZIMM modular system

At ZIMM, speed, know-how and customer friendliness have a system. The ZIMM modular system sets a standard with its scope, versatility and possible combinations.

And above all, it offers you the possibility of putting together really complete lifting systems with attachments, connecting shafts, safety features and other.

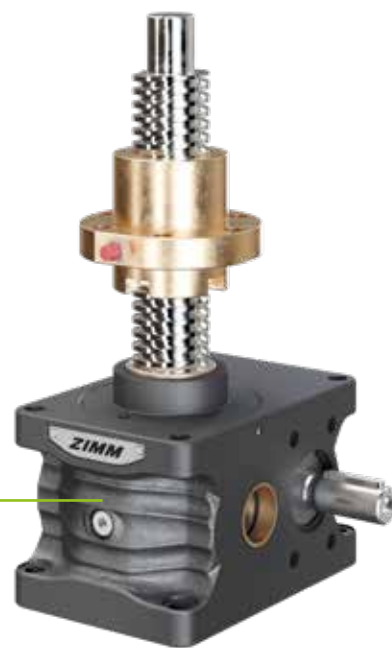

### Basic element

ZIMM screw jack in 14 sizes  
with a lifting force of 2,5 kN to 1,000 kN;  
more than 1,000 system components ex stock,  
more than 7,000 combinations possible

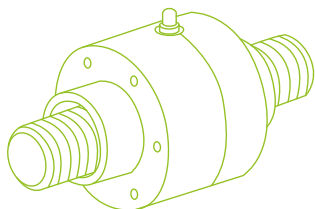

- + Spindles and nuts**  
Versatile range from  
16 to 160 mm in diameter  
for trapezoidal and ball screws

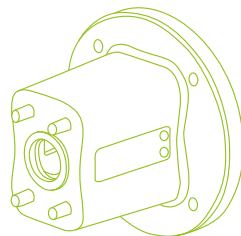

- + Flanges, motors and attachments**  
Common flanges, motors  
and guards

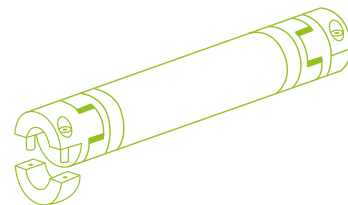

- + Connection shafts**  
Large selection of connection  
shafts and couplings

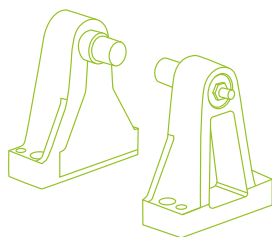

- + Accessories for  
swivelling and tilting**  
Suitable for all gear sizes

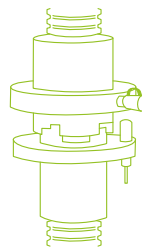

- + Security solutions**  
Standard components protect  
people and systems from failure

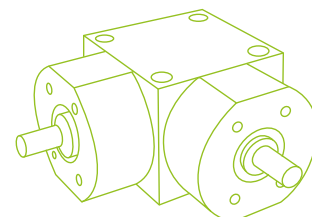

- + Bevel gear units**  
42 different high-performance  
bevel gear units

# THE ZIMM MODULAR SYSTEM

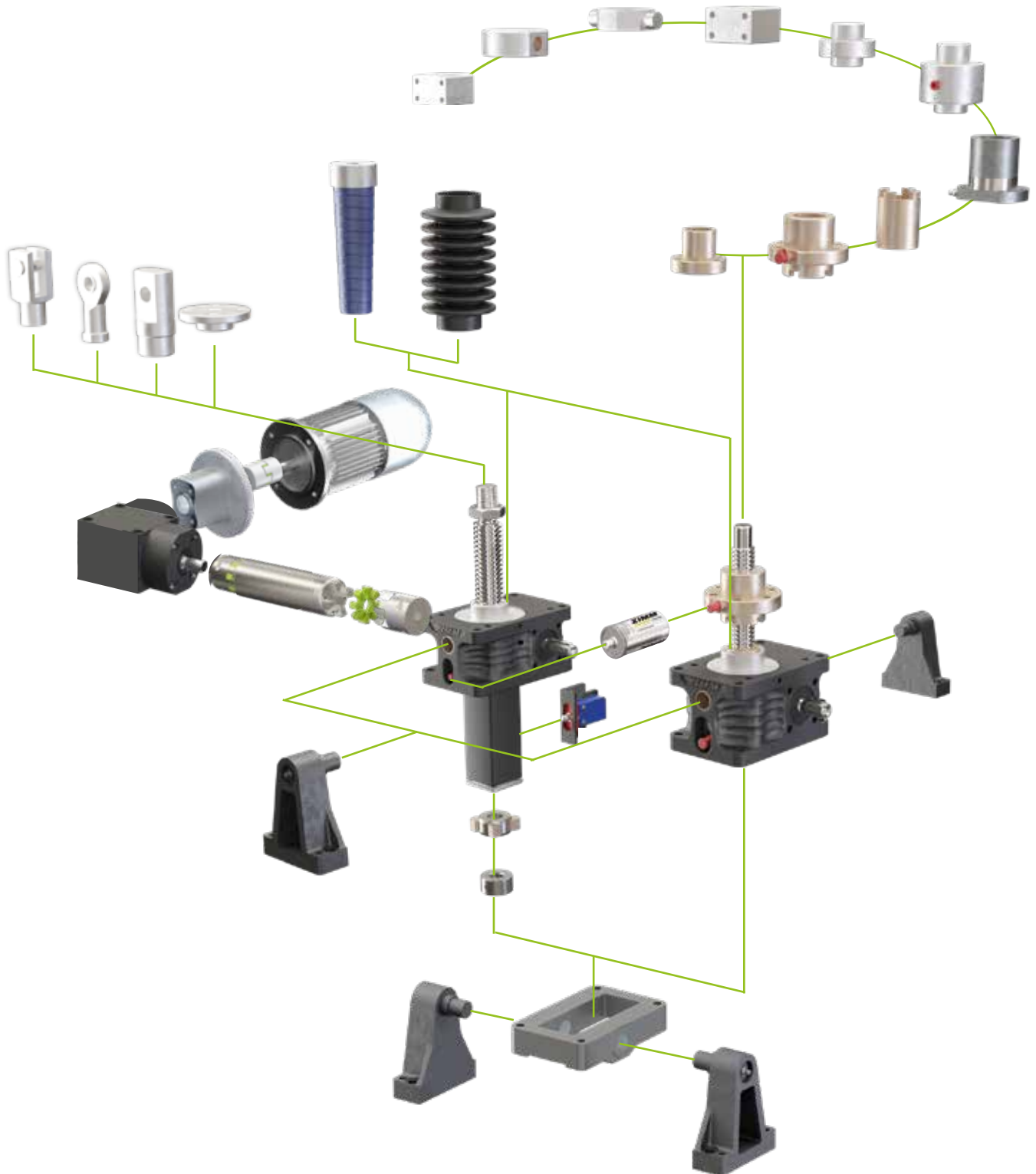



# CHAPTER 2

## Screw jack

<b>Tr</b>	<b>Trapezoidal screw (Tr), S + R-Version</b>	
	ZE-Series (Tr), 5 kN	16
	ZE-Series (Tr), 10 kN	18
	ZE-Series (Tr), 25 kN	20
	ZE-Series (Tr), 35 kN	22
	ZE-Series (Tr), 50 kN	24
	ZE-Series, Tr-50-S kN Increased screw (Only S-Version)	26
	ZE-Series (Tr), 100 kN	28
	ZE-Series (Tr), 150 kN	30
	ZE-Series (Tr), 200 kN	32
	Z-Series (Tr), 250 kN	34
	Z-Series (Tr), 350 kN	36
	Z-Series (Tr), 500 kN	38
	Z-Series (Tr), 750 kN	40
	Z-Series (Tr), 1000 kN	42
<b>SIFA</b>	<b>Security &amp; inspection</b>	44
	SIFA-S for translating screw, 10 - 350 kN	46
	SIFA-R for rotating screw, 2 - 1000 kN	48
<b>KGT</b>	<b>Ball screw (KGT), S + R-Version</b>	
	KGT Guide & information	50
	ZE-Series (KGT), S-Version 5 - 25 kN	52
	ZE-Series (KGT), S-Version 50 - 200 kN	54
	Z-Series (KGT), S-Version 250 - 350 kN	56
	Z-Series (KGT), S-Version 500 - 1000 kN	58
	ZE-Series (KGT), R-Version 5 - 25 kN	60
	ZE-Series (KGT), R-Version 35 - 100 kN	62
	ZE-Series (KGT), R-Version 150 - 200 kN	64
	Z-Series (KGT), R-Version 250 - 350 kN	66
	Z-Series (KGT), R-Version 500 - 1000 kN	68
<b>ZE-H</b>	<b>ZE-H Features &amp; Duty cycle thermal limit</b>	
	ZE-H-Series, 35 - 200 kN	70
<b>GSZ</b>	<b>Cubic screw jack series GSZ</b>	
	GSZ-Series (Tr), S + R-Version, 2,5 - 150 kN	72
	GSZ-Series (KGT), S + R-Version, 5 - 150 kN	90

**5 kN**  
**ZE-5-S** | translating screw

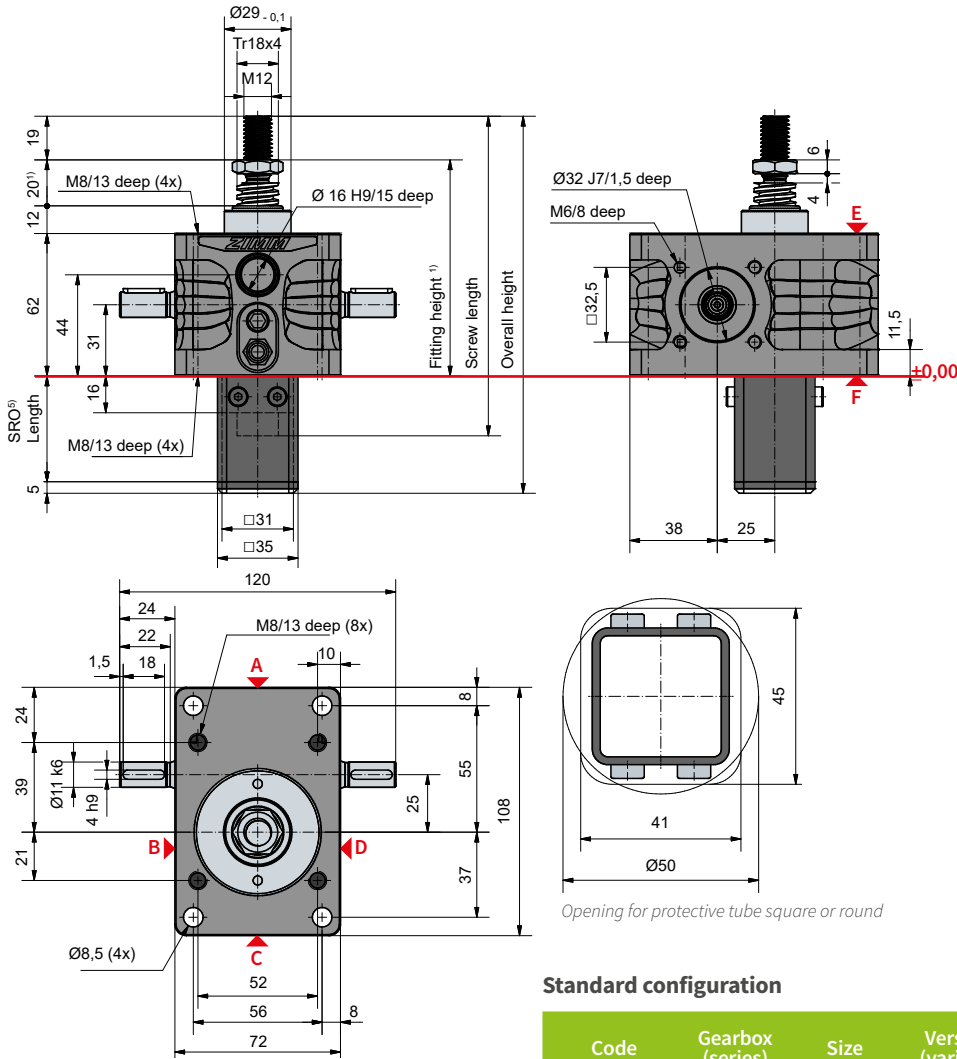

**Protective tube length SRO with Tr 18x4-screw**

Without escape/rotation protection	46 + stroke
Escape/rotation protection	61 + stroke
Rotation protection, with limit switch se ESSET	119 + stroke
Rotation protection with ESSET and KAR	140 + stroke

**Standard configuration**

Code	Gearbox (series)	Size	Version (variant)	Ratio	Screw	Stroke per drive shaft rotation
ZE-5-SN	ZE	5	S (translating screw)	N (normal) 4:1	Tr 18x4	1,00 mm
ZE-5-SL				L (low) 16:1		0,25 mm

**5 kN**

**Duty cycle thermal limit (S + R)**

Ratio „N“ (4:1)

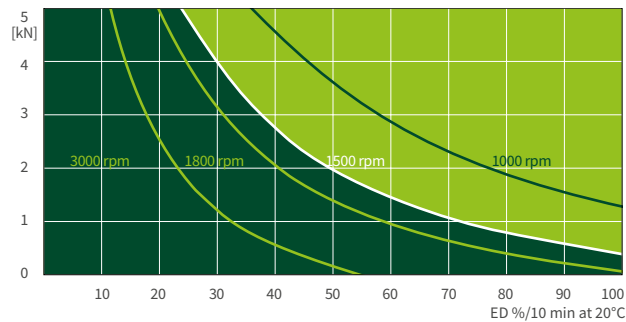

Ratio „L“ (16:1)

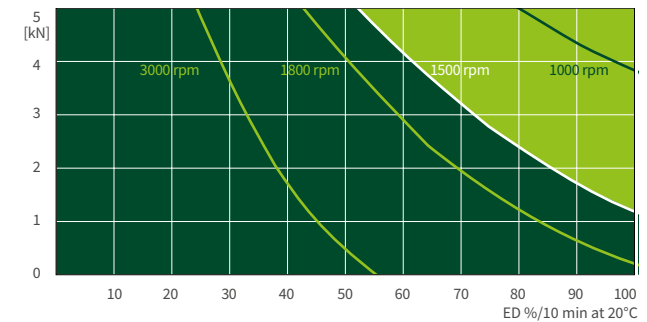

These curves are for guidance under standard industrial conditions (ambient temperature 20°C etc.) and correct maintenance (lubrication etc.). They are based on the ZIMM standard trapezoidal thread Tr 18x4. With the use of a ball screw, the operation cycles can be many times longer.





# 5 kN ZE-5-R | rotating screw

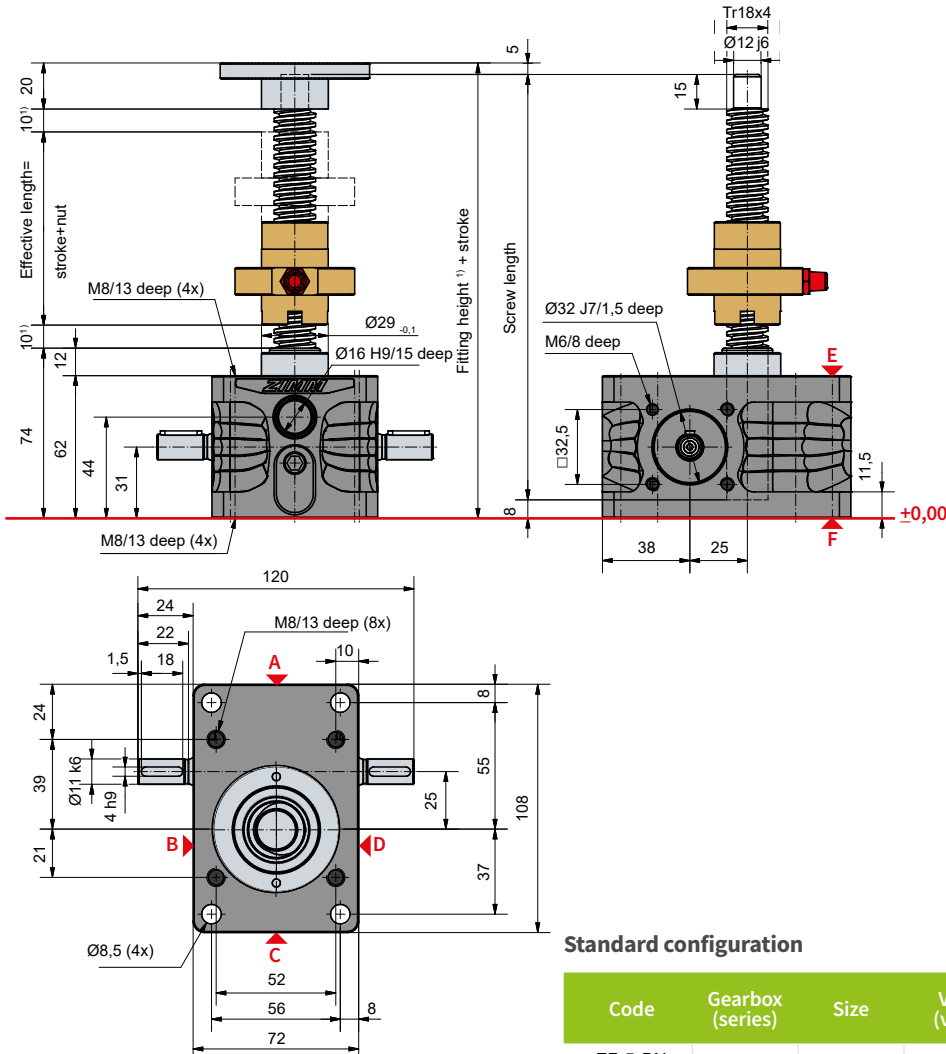

### Standard configuration

Code	Gearbox (series)	Size	Version (variant)	Ratio	Screw	Stroke per drive shaft rotation
ZE-5-RN	ZE	5	R (rotating screw)	N (normal) 4:1	Tr 18x4	1,00 mm
ZE-5-RL				L (low) 16:1		0,25 mm

### Technical data series ZE-5-S / ZE-5-R

max. compressive/tensile force, static:	5 kN (0,5 t)
max. compressive/tensile force, dyn.:	see duty cycle curves
Input speed:	1500 rpm / max. 3000 rpm (depending on the load and duty cycle)
Screw size standard:	Tr 18x4 <sup>2)</sup>
Gear ratio:	4:1 (N) / 16:1 (L)
Housing material:	aluminium, corrosion-resistant
Worm shaft:	steel, case-hardened, ground
Weight of screw jack body:	1,2 kg
Weight of screw/m:	1,58 kg
Gearbox lubrication:	synthetic fluid grease
Screw lubrication:	grease lubrication
Gearbox operating temperature:	max. 60°C, higher on request
Moment of inertia:	N: 0,132 kg cm <sup>2</sup> / L: 0,091 kg cm <sup>2</sup>
Input torque (at 1500 rpm):	max. 4,7 Nm (N) / max. 1,5 Nm (L)
Drive-through torque:	max. 39 Nm
Drive torque M <sub>G</sub> (Nm):	F (kN) x 0,62 <sup>3,4)</sup> (N-Normal) F (kN) x 0,21 <sup>3,4)</sup> (L-Low)
Breakaway torque:	Drive torque M <sub>G</sub> x 1,5

Between gearbox and nut or nut and end of thread, provide for a safety distance of (minimum) 10 mm!

Detailed calculation of the fitting dimensions (bellows, screw, protective tube...) can be conveniently determined with our online configurator: [40www.zimm.com](http://40www.zimm.com)

#### Important information:

- 1) If a bellows, spiral spring or double pitch is used more fitting space is required
- 2) Tr 18x4 is standard, also available: double-pitch, INOX, eft-handed, increased screw Tr 20x4 (only for the R-Version)
- 3) factor includes efficiency, ratio and 30% safety
- 4) for a 4 mm screw pitch
- 5) to calculate the length of our protective tube length SRO simply use our online configurator: [www.zimm.com](http://www.zimm.com)

**10 kN**  
**ZE-10-S** | translating screw

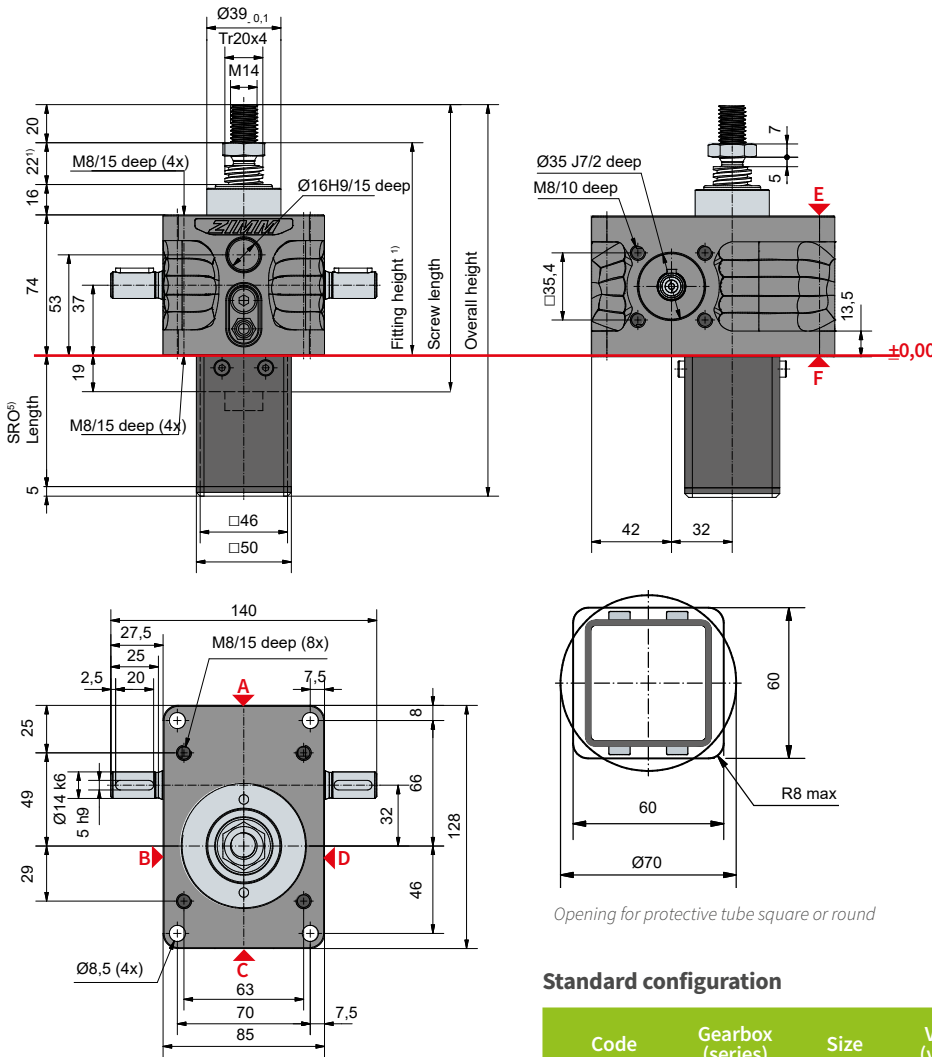

**Protective tube length SRO with Tr 20x4-Screw**

Without escape/rotation protection	49 + stroke
Escape/rotation protection	69 + stroke
Rotation protection, with limit switch set ESSET	121 + stroke
Rotation protection with ESSET and KAR	141 + stroke

**Standard configuration**

Code	Gearbox (series)	Size	Version (variant)	Ratio	Screw	Stroke per drive shaft rotation
ZE-10-SN	ZE	10	S (translating screw)	N (normal) 4:1	Tr 20x4	1,00 mm
ZE-10-SL				L (low) 16:1		0,25 mm

**10 kN**

**Duty cycle thermal limit (S + R)**

Ratio „N“ (4:1)

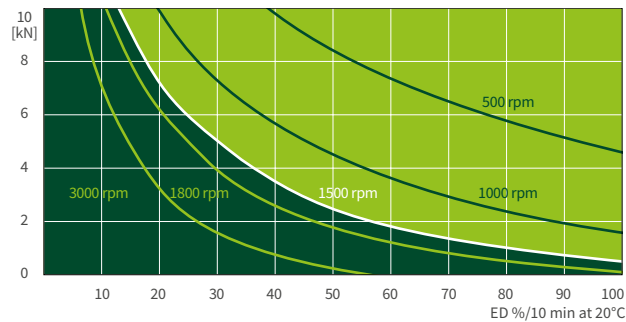

Ratio „L“ (16:1)

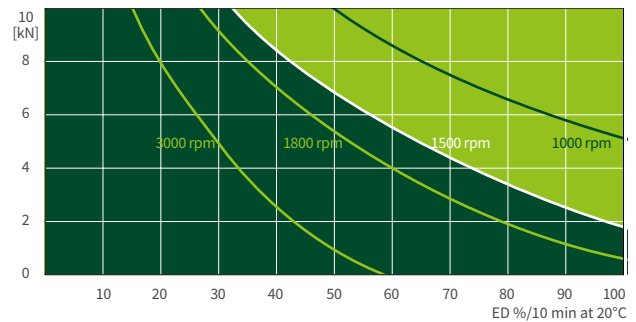

These curves are for guidance under standard industrial conditions (ambient temperature 20°C etc.) and correct maintenance (lubrication etc.). They are based on the ZIMM standard trapezoidal thread Tr 20x4. With the use of a ball screw, the operation cycles can be many times longer.



# 10 kN

## ZE-10-R | rotating screw

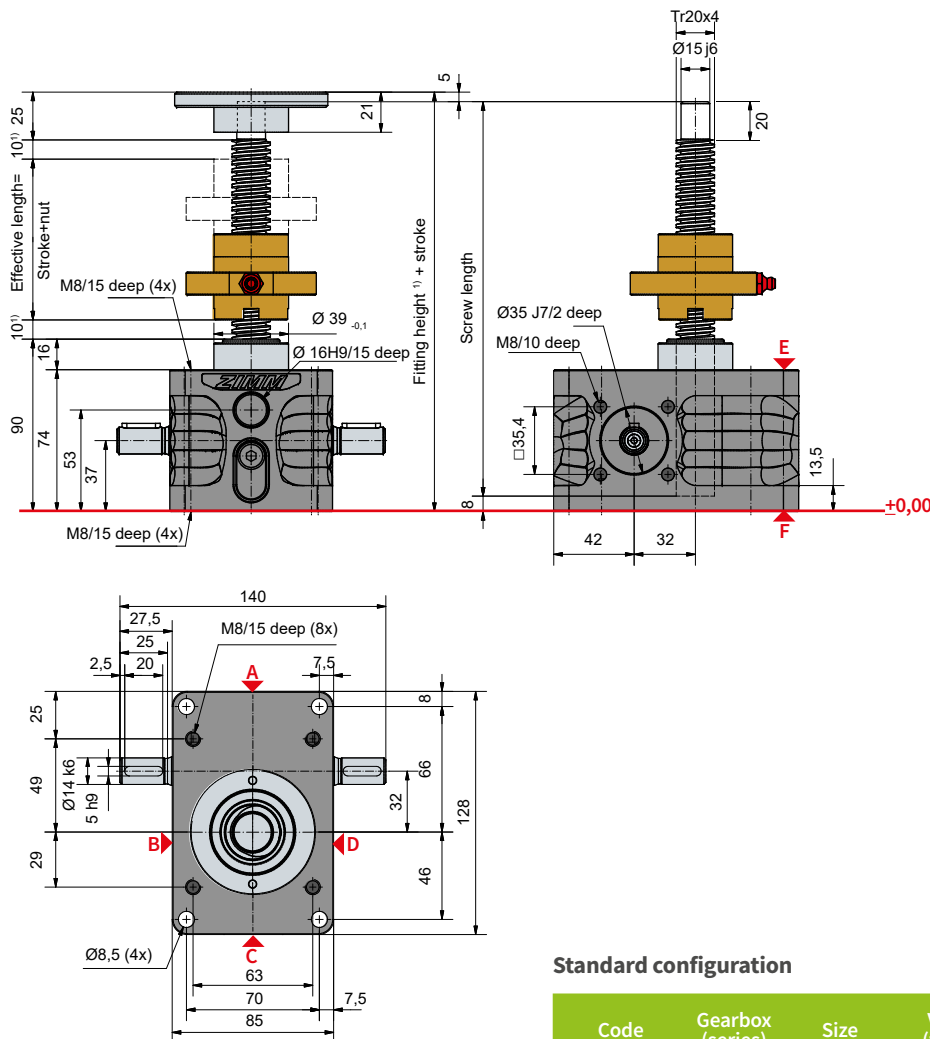

### Standard configuration

Code	Gearbox (series)	Size	Version (variant)	Ratio	Screw	Stroke per drive shaft rotation
ZE-10-RN	ZE	10	R (rotating screw)	N (normal) 4:1	Tr 20x4	1,00 mm
ZE-10-RL				L (low) 16:1		0,25 mm

### Technical data series ZE-10-S / ZE-10-R

max. compressive/tensile force, static:	10 kN (1 t)
max. compressive/tensile force, dyn.:	see duty cycle curves
Input speed:	1500 rpm / max. 3000 rpm (depending on the load and duty cycle)
Screw size standard:	Tr 20x4 <sup>2)</sup>
Gear ratio:	4:1 (N) / 16:1 (L)
Housing material:	aluminium, corrosion-resistant
Worm shaft:	steel, case-hardened, ground
Weight of screw jack body:	2,1 kg
Weight of screw/m:	2 kg
Gearbox lubrication:	synthetic fluid grease
Screw lubrication:	grease lubrication
Gearbox operating temperature:	max. 60°C, higher on request
Moment of inertia:	N: 0,361 kg cm <sup>2</sup> / L: 0,226 kg cm <sup>2</sup>
Input torque (at 1500 rpm):	max. 13,5 Nm (N) / max. 7,5 Nm (L)
Drive-through torque:	max. 57 Nm
Drive torque M <sub>G</sub> (Nm):	F (kN) x 0,64 <sup>3,4)</sup> (N-Normal) F (kN) x 0,20 <sup>3,4)</sup> (L-Low)
Breakaway torque:	Drive torque M <sub>G</sub> x 1,5

Between gearbox and nut or nut and end of thread, provide for a safety distance of (minimum) 10 mm!

Detailed calculation of the fitting dimensions (bellows, screw, protective tube...) can be conveniently determined with our online configurator: [www.zimm.com](http://www.zimm.com)

#### Important information:

- 1) If a bellows, spiral spring or double pitch is used more fitting space is required
- 2) Tr 20x4 is standard, also available: double-pitch, INOX, left-handed, increased screw Tr 30x6 (only for the R-Version)
- 3) factor includes efficiency, ratio and 30% safety
- 4) for a 4 mm screw pitch
- 5) to calculate the length of our protective tube length SRO simply use our online configurator: [www.zimm.com](http://www.zimm.com)

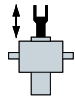

# 25 kN

## ZE-25-S | translating screw

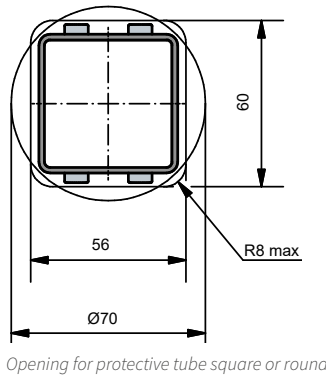
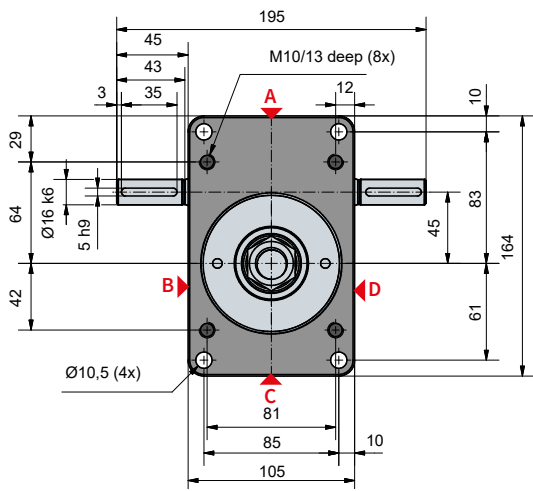
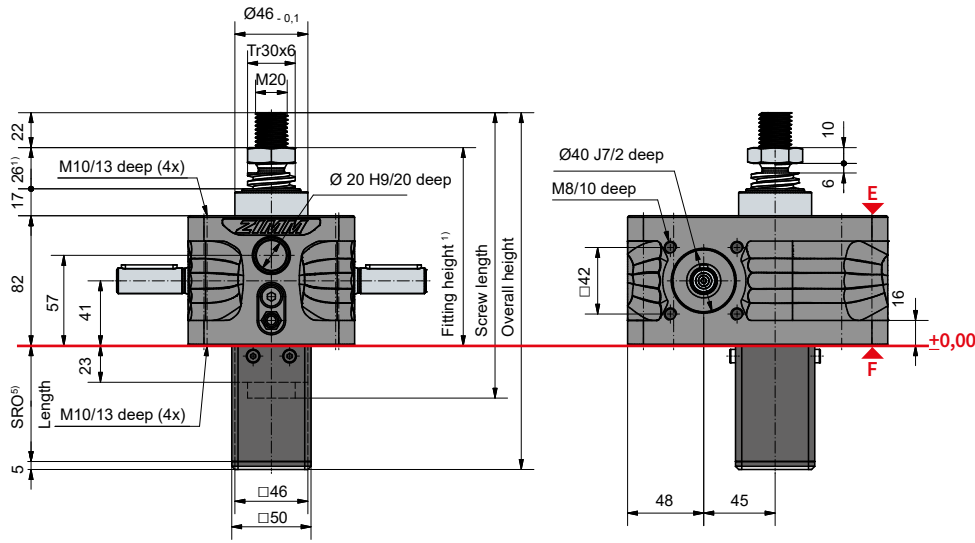

Opening for protective tube square or round

### Protective tube length SRO with Tr 30x6-Screw

Without escape/rotation protection	53 + stroke
Escape/rotation protection	73 + stroke
Rotation protection, with limit switch set ESSET	125 + stroke
Rotation protection with ESSET and KAR	149 + stroke

### Standard configuration

Code	Gearbox (series)	Size	Version (variant)	Ratio	Screw	Stroke per drive shaft rotation
ZE-25-SN	ZE	25	S (translating screw)	N (normal) 6:1	Tr 30x6	1,00 mm
ZE-25-SL				L (low) 24:1		0,25 mm

# 25 kN

## Duty cycle thermal limit (S + R)

Ratio „N“ (6:1)

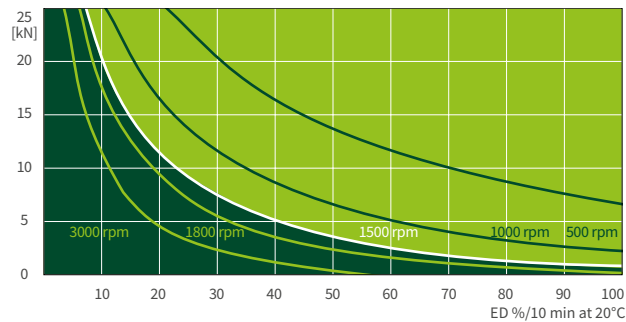

Ratio „L“ (24:1)

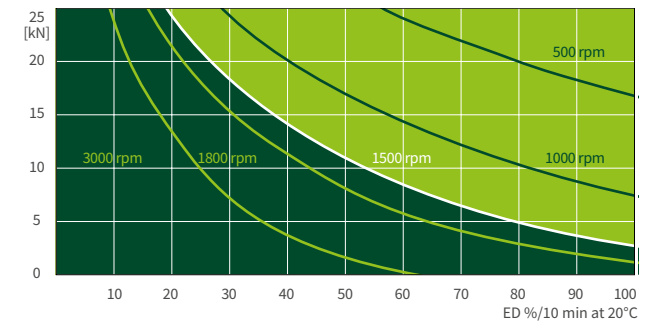

These curves are for guidance under standard industrial conditions (ambient temperature 20°C etc.) and correct maintenance (lubrication etc.). They are based on the ZIMM standard trapezoidal thread Tr 30x6. With the use of a ball screw, the operation cycles can be many times longer.



# 25 kN

## ZE-25-R | rotating screw

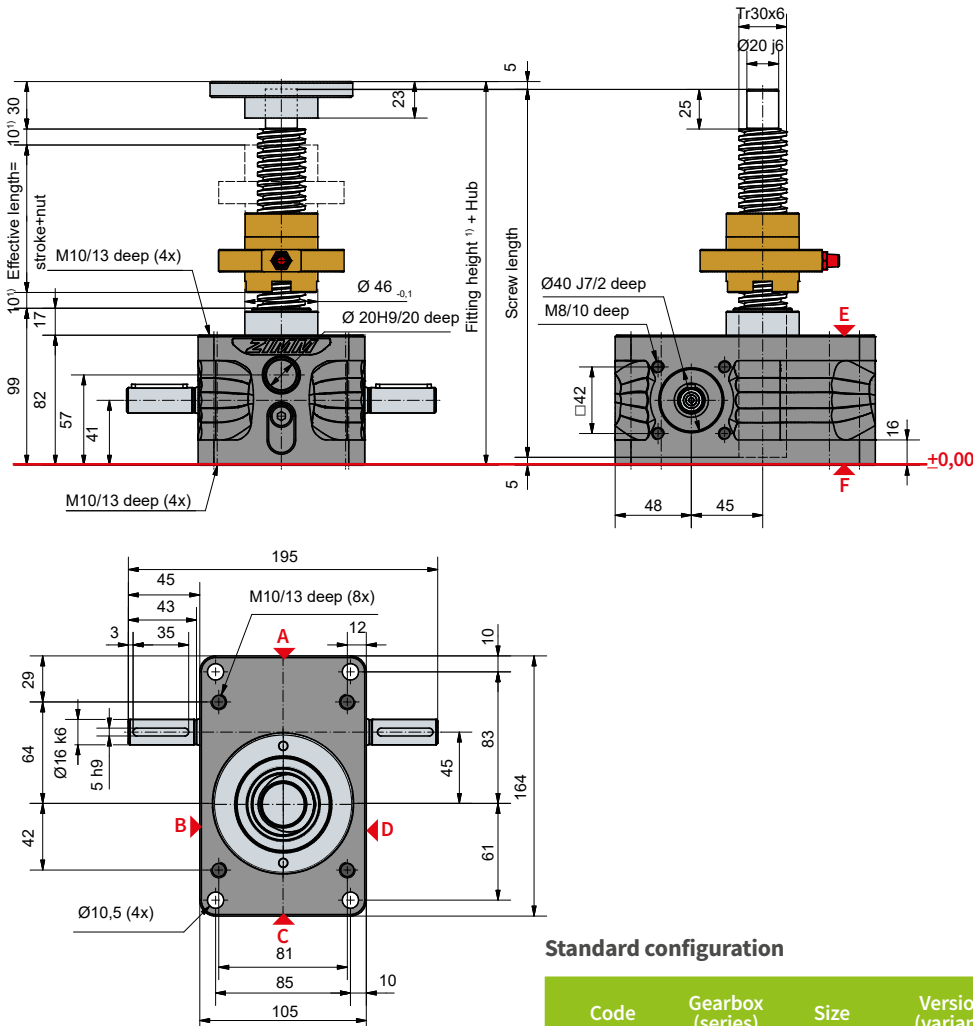

### Standard configuration

Code	Gearbox (series)	Size	Version (variant)	Ratio	Screw	Stroke per drive shaft rotation
ZE-25-RN	ZE	25	R (rotating screw)	N (normal) 6:1	Tr 30x6	1,00 mm
ZE-25-RL				L (low) 24:1		0,25 mm

### Technical data series ZE-25-S / ZE-25-R

max. compressive/tensile force, static:	25 kN (2,5 t)
max. compressive/tensile force, dyn.:	see duty cycle curves
Input speed:	1500 rpm / max. 3000 rpm (depending on the load and duty cycle)
Screw size standard:	Tr 30x6 <sup>2)</sup>
Gear ratio:	6:1 (N) / 24:1 (L)
Housing material:	aluminium, corrosion-resistant
Worm shaf:	steel, case-hardened, ground
Weight of screw jack body:	3,8 kg
Weight of screw/m:	4,5 kg
Gearbox lubrication:	synthetic fluid grease
Screw lubrication:	grease lubrication
Gearbox operating temperature:	max. 60°C, higher on request
Moment of inertia:	N: 0,667 kg cm <sup>2</sup> / L: 0,443 kg cm <sup>2</sup>
Input torque (at 1500 rpm):	max. 18 Nm (N) / max. 10 Nm (L)
Drive-through torque:	max. 108 Nm
Drive torque M <sub>G</sub> (Nm):	F (kN) x 0,63 <sup>3,4)</sup> (N-Normal) F (kN) x 0,20 <sup>3,4)</sup> (L-Low)
Breakaway torque:	Drive torque M <sub>G</sub> x 1,5

Between gearbox and nut or nut and end of thread, provide for a safety distance of (minimum) 10 mm!

Detailed calculation of the fitting dimensions (bellows, screw, protective tube...) can be conveniently determined with our online configurator: [www.zimm.com](http://www.zimm.com)

#### Important information:

- 1) If a bellows, spiral spring or double pitch is used more fitting space is required
- 2) Tr 30x6 is standard, also available: double-pitch, INOX, left-handed, increased screw Tr 40x7 (only for the R-Version)
- 3) factor includes efficiency, ratio and 30% safety
- 4) for a 6 mm screw pitch
- 5) to calculate the length of our protective tube length SRO simply use our online configurator: [www.zimm.com](http://www.zimm.com)

**35 kN**  
**ZE-35-S** | translating screw

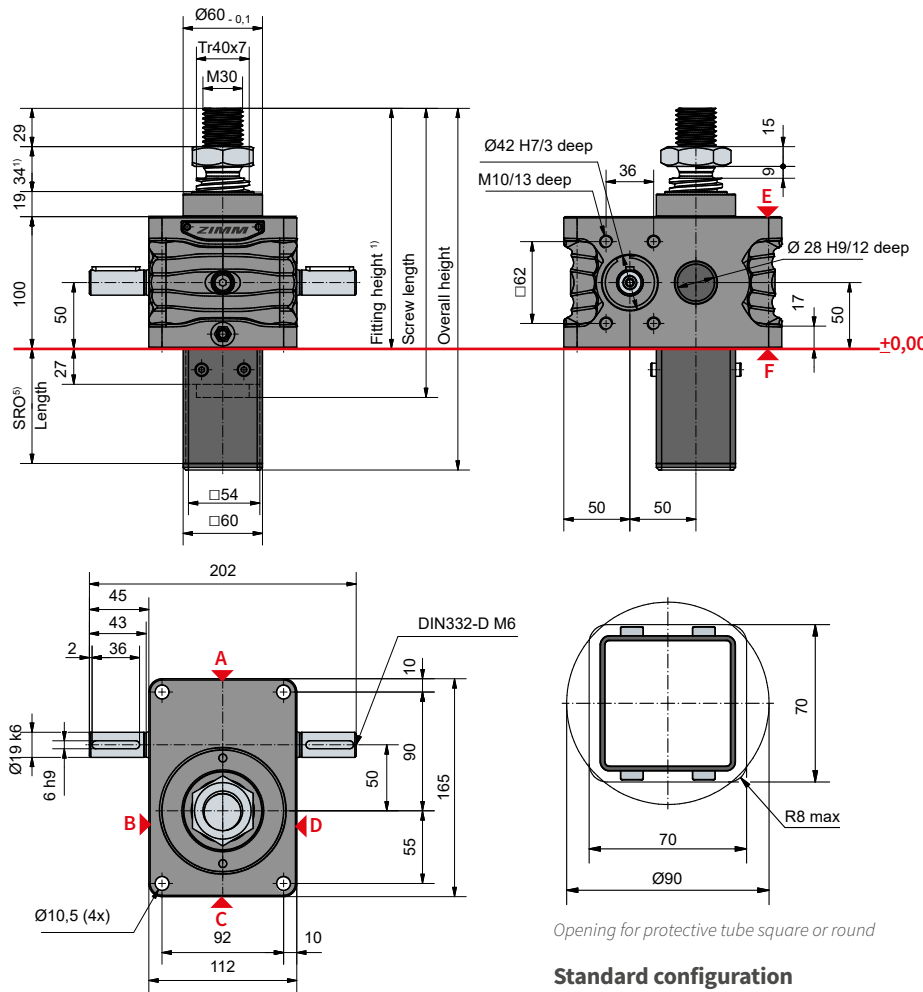

**Protective tube length SRO with Tr 40x7-Screw**

Without escape/rotation protection	57 + stroke
Escape/rotation protection	87 + stroke
Rotation protection, with limit switch set ESSET	143 + stroke

Opening for protective tube square or round

**Standard configuration**

Code	Gearbox (series)	Size	Version (variant)	Ratio	Screw	Stroke per drive shaft rotation
ZE-35-SN	ZE	35	S (translating screw)	N (normal) 7:1	Tr 40x7	1,00 mm
ZE-35-SL				L (low) 28:1		0,25 mm

**35 kN**

**Duty cycle thermal limit (S + R)**

Ratio „N“ (7:1)

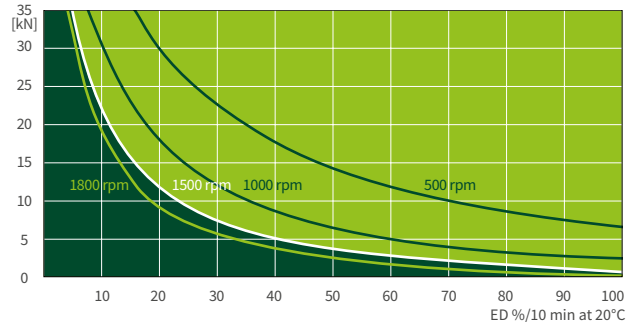

Ratio „L“ (28:1)

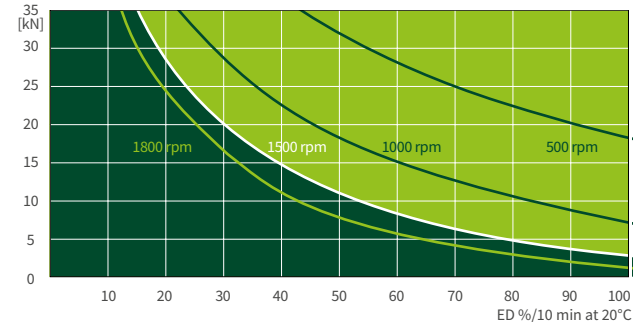

These curves are for guidance under standard industrial conditions (ambient temperature 20°C etc.) and correct maintenance (lubrication etc.). They are based on the ZIMM standard trapezoidal thread Tr 40x7. With the use of a ball screw, the operation cycles can be many times longer. In case you need an even longer duration or performance, you will find information about our ZE-H high performance gearboxes on page 70 and 71.



**S** 50 kN  
**ZE-50-S** | translating screw

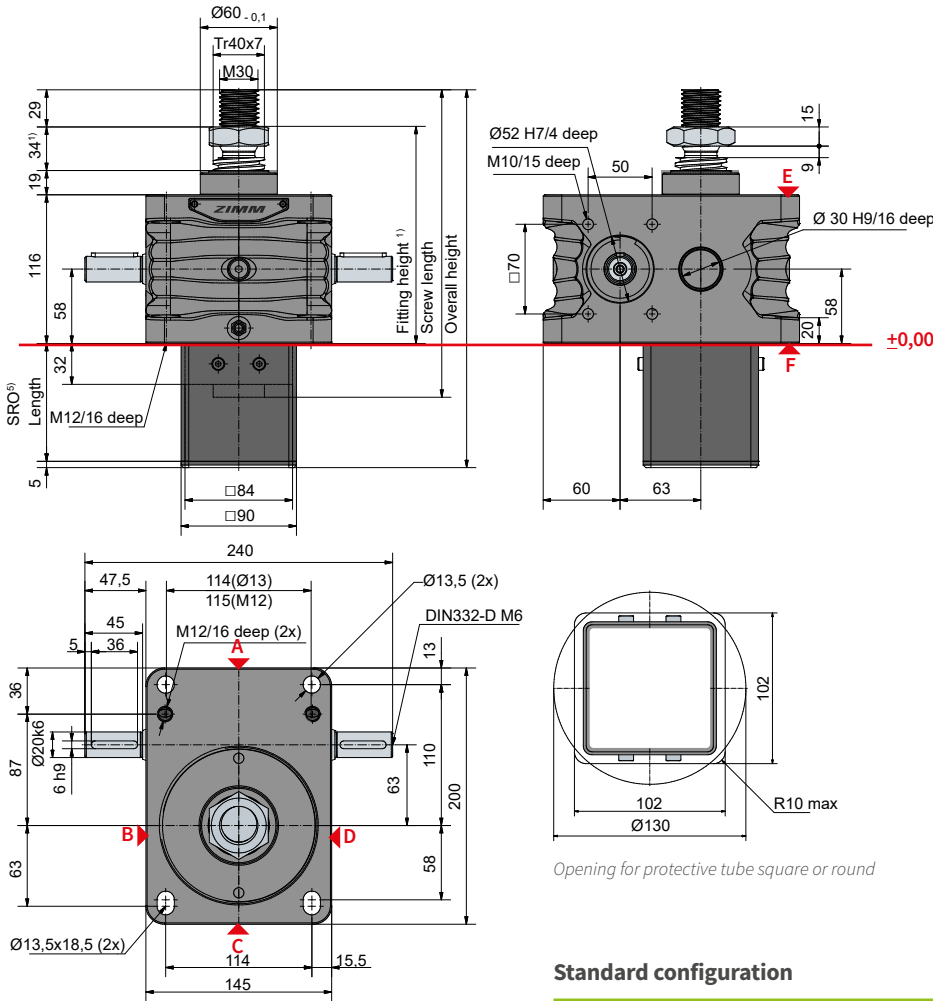

**Protective tube length SRO with Tr 40x7-Screw**

Without escape/rotation protection	62 + stroke
Escape/rotation protection	92 + stroke
Rotation protection, with limit switch set ESSET	144 + stroke

Opening for protective tube square or round

**Standard configuration**

Code	Gearbox (series)	Size	Version (variant)	Ratio	Screw	Stroke per drive shaft rotation
ZE-50-SN	ZE	50	S (translating screw)	N (normal) 7:1	Tr 40x7	1,00 mm
ZE-50-SL				L (low) 28:1		0,25 mm

**50 kN**

**Duty cycle thermal limit (S + R)**

Ratio „N“ (7:1)

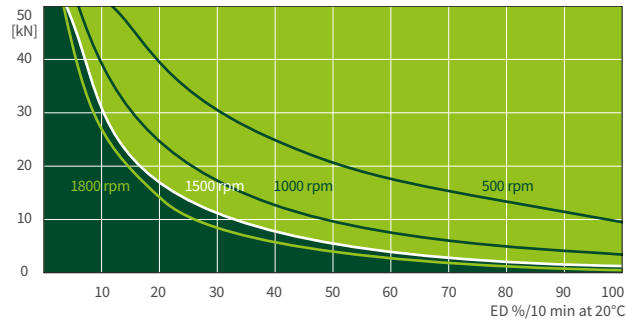

Ratio „L“ (28:1)

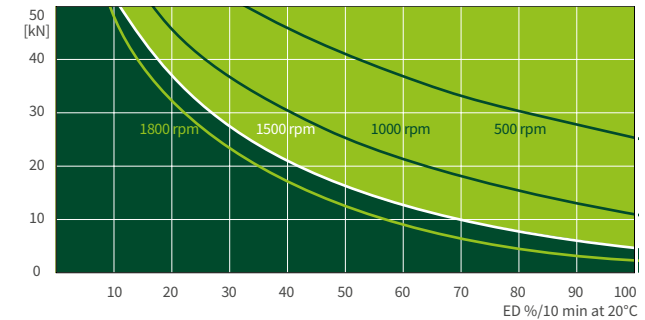

These curves are for guidance under standard industrial conditions (ambient temperature 20°C etc.) and correct maintenance (lubrication etc.). They are based on the ZIMM standard trapezoidal thread Tr 40x7. With the use of a ball screw, the operation cycles can be many times longer. In case you need an even longer duration or performance, you will find information about our ZE-H high performance gearboxes on page 70 and 71.





**S** 50 kN  
**ZE-50/Tr50-S** | translating screw

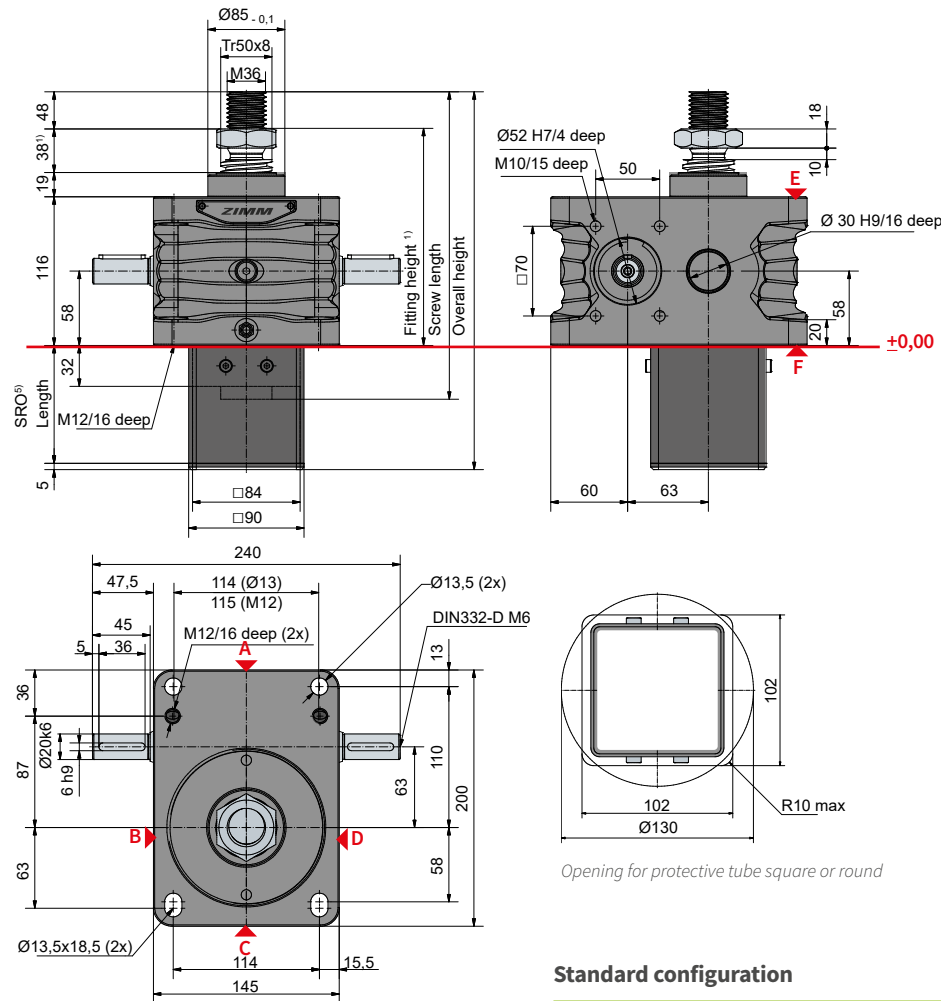

**Protective tube length SRO with Tr 50x8-Screw**

Without escape/rotation protection	62 + stroke
Escape/rotation protection	92 + stroke
Rotation protection, with limit switch set ESSET	144 + stroke

Für ZE-50/Tr50 wird spindelseitiges Zubehör von ZE-100 verwendet.

**Standard configuration**

Code	Gearbox (series)	Size	Version (variant)	Ratio	Screw	Stroke per drive shaft rotation
ZE-50/Tr50-SN	ZE	50	S (translating screw)	N (normal) 7:1	Tr 50x8	1,143 mm
ZE-50/Tr50-SL				L (low) 28:1		0,286 mm

**50 kN**

**Duty cycle thermal limit (S + R)**

Ratio „N“ (7:1)

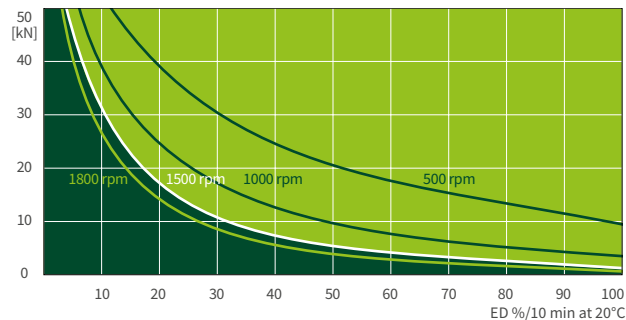

Ratio „L“ (28:1)

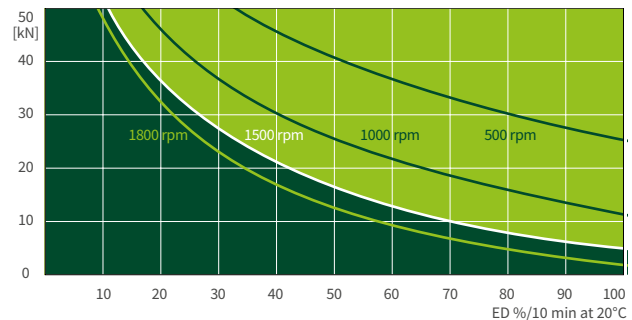

These curves are for guidance under standard industrial conditions (ambient temperature 20°C etc.) and correct maintenance (lubrication etc.). They are based on the ZIMM standard trapezoidal thread Tr 50x8. With the use of a ball screw, the operation cycles can be many times longer. In case you need an even longer duration or performance, you will find information about our ZE-H high performance gearboxes on page 70 and 71.

# HEAVY DUTY SCREWS FOR LONG STROKES

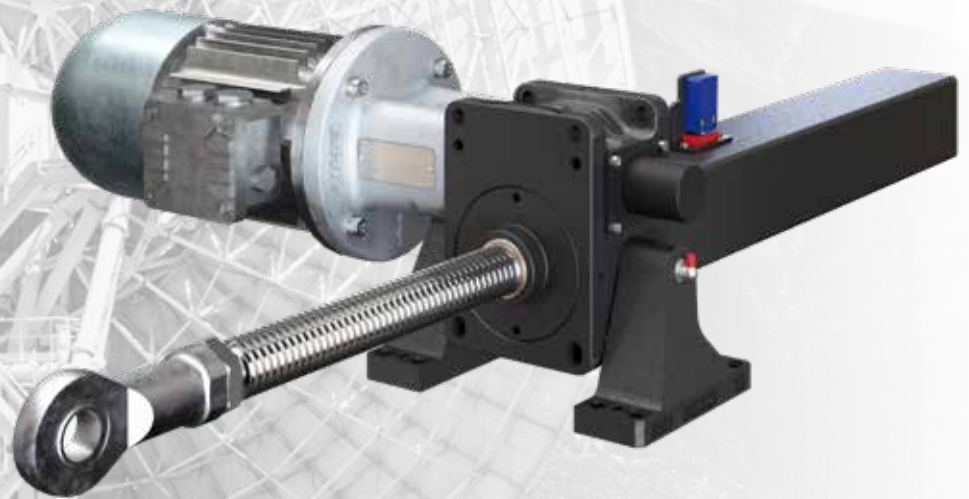

## Heavy duty screws

Specially designed with stronger spindle for more stability. Usually, for large stroke lengths, the spindle diameter is decisive for the design. Due to the increased spindle, the gearbox does not have to be oversized.

## Technical data series ZE-50-S / Tr50-S

max. compressive/tensile force, static:	50 kN (5 t)
max. compressive/tensile force, dyn:	see duty cycles curves
Input speed:	1500 rpm / max. 1800 rpm (depending on the load and duty cycle)
Screw size standard:	Tr 50x8 <sup>2)</sup>
Gear ratio:	7:1 (N) / 28:1 (L)
Housing material:	GGG, corrosion-resistant
Worm shaft:	steel, case-hardened, ground
Weight of screw jack body:	17 kg
Weight of screw/m:	13 kg
Gearbox lubrication:	synthetic fluid grease
Screw lubrication:	grease lubrication
Gearbox operating temperature:	max. 60°C, higher on request
Moment of inertia:	N: 2,49 kg cm <sup>2</sup> / L: 1,73 kg cm <sup>2</sup>
Input torque (at 1500 rpm):	max. 31,5 Nm (N) / max. 10,4 Nm (L)
Drive-through torque:	max. 260 Nm
Drive torque M <sub>G</sub> (Nm):	F (kN) x 0,68 <sup>3,4)</sup> (N-Normal) F (kN) x 0,23 <sup>3,4)</sup> (L-Low)
Breakaway torque:	Drive torque M <sub>G</sub> x 1,5

Make a plan to keep a safe distance of at least 10 mm between gearbox and nut or between nut and threaded end!

Detailed calculation of the fitting dimensions (bellows, screw, protective tube...) can be conveniently determined with our online configurator: [www.zimm.com](http://www.zimm.com)

## Important information:

- 1) If a bellows, spiral spring or double pitch is used more fitting space is required
- 2) Tr 50x8 is standard, also available: double-pitch, INOX, left-handed
- 3) factor includes efficiency, ratio and 30% safety
- 4) for a 8 mm screw pitch
- 5) to calculate the length of our protective tube length SRO simply use our online configurator: [www.zimm.com](http://www.zimm.com)

**S** 100 kN  
**ZE-100-S** | translating screw

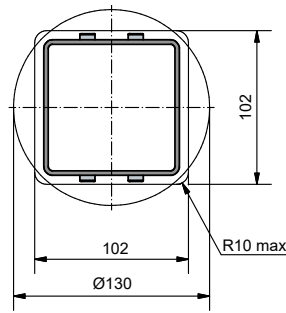
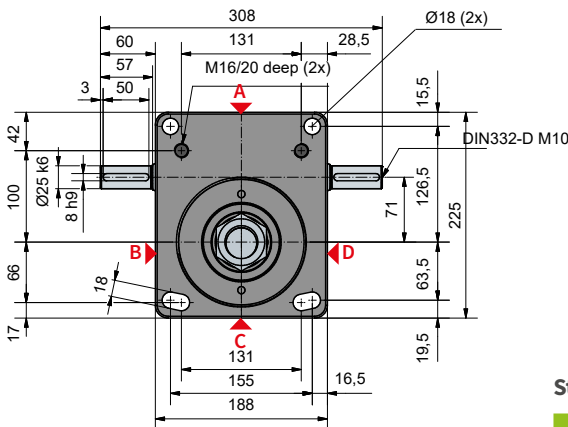
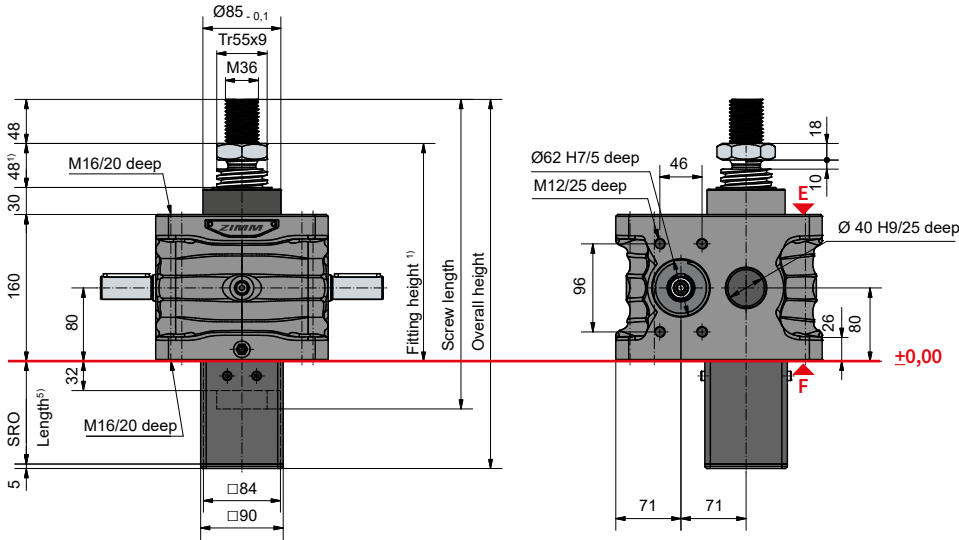

Opening for protective tube square or round

**Protective tube length SRO with Tr 55x9-Screw**

Without escape/rotation protection	82 + stroke
Escape/rotation protection	112 + stroke
Rotation protection, with limit switch set ESSET	144 + stroke

**Standard configuration**

Code	Gearbox (series)	Size	Version (variant)	Ratio	Screw	Stroke per drive shaft rotation
ZE-100-SN	ZE	100	S (translating screw)	N (normal) 9:1	Tr 55x9	1,00 mm
ZE-100-SL			L (low) 36:1	0,25 mm		

100 kN

**Duty cycle thermal limit (S + R)**

Ratio „N“ (9:1)

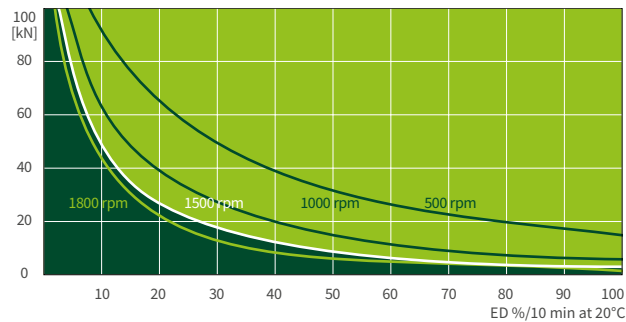

Ratio „L“ (36:1)

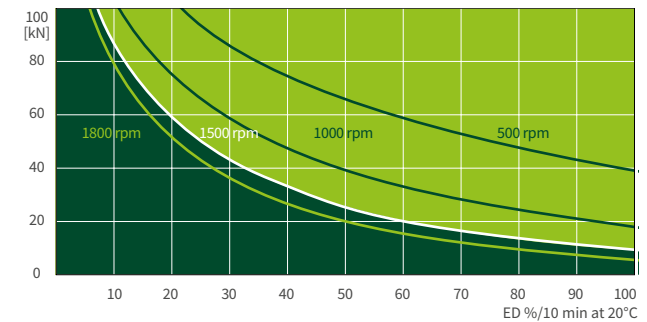

These curves are for guidance under standard industrial conditions (ambient temperature 20°C etc.) and correct maintenance (lubrication etc.). They are based on the ZIMM standard trapezoidal thread Tr 55x9. With the use of a ball screw, the operation cycles can be many times longer. In case you need an even longer duration or performance, you will find information about our ZE-H high performance gearboxes on page 70 and 71.



# R 100 kN

## ZE-100-R | rotating screw

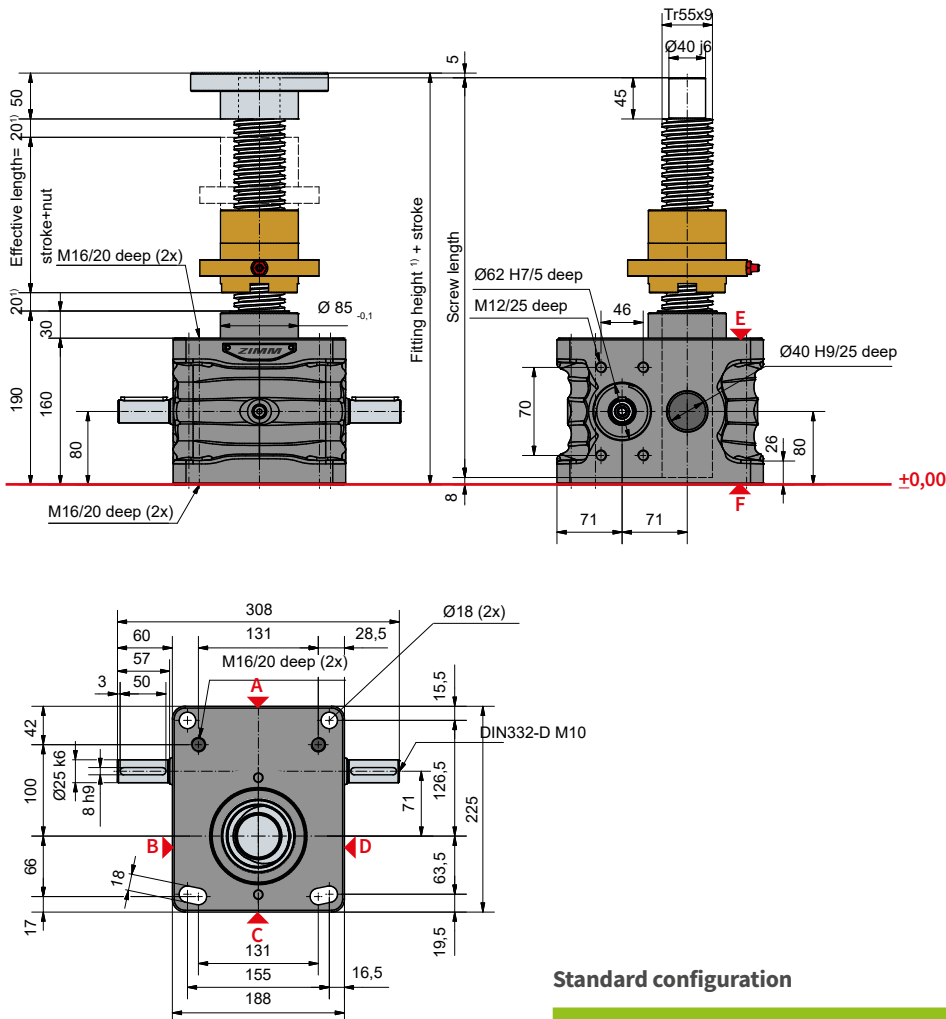

### Standard configuration

Code	Gearbox (series)	Size	Version (variant)	Ratio	Screw	Stroke per drive shaft rotation
ZE-100-RN	ZE	100	R (rotating screw)	N (normal) 9:1	Tr 55x9	1,00 mm
ZE-100-RL				L (low) 36:1		0,25 mm

### Technical data series ZE-100-S / ZE-100-R

max. compressive/tensile force, static:	100 kN (10 t)
max. compressive/tensile force, dyn:	see duty cycle curves
Input speed:	1500 rpm / max. 1800 rpm (depending on the load and duty cycle)
Screw size standard:	Tr 55x9 <sup>2)</sup>
Gear ratio:	9:1 (N) / 36:1 (L)
Housing material:	GGG, corrosion-resistant
Worm shaft:	steel, case-hardened, ground
Weight of screw jack body:	29 kg
Weight of screw/m:	15,7 kg
Gearbox lubrication:	synthetic fluid grease
Screw lubrication:	grease lubrication
Gearbox operating temperature:	max. 60°C, higher on request
Moment of inertia:	N: 4,66 kg cm <sup>2</sup> / L: 3,38 kg cm <sup>2</sup>
Input torque (at 1500 rpm):	max. 53,4 Nm (N) / max. 13,5 Nm (L)
Drive-through torque:	max. 540 Nm
Drive torque M <sub>G</sub> (Nm):	F (kN) x 0,72 <sup>3,4)</sup> (N-Normal) F (kN) x 0,23 <sup>3,4)</sup> (L-Low)
Breakaway torque:	Drive torque M <sub>G</sub> x 1,5

Make a plan to keep a safe distance of at least 20 mm between gearbox and nut or between nut and threaded end!

Detailed calculation of the fitting dimensions (bellows, screw, protective tube...) can be conveniently determined with our online configurator: [www.zimm.com](http://www.zimm.com)

#### Important information:

- 1) If a bellows, spiral spring or double pitch is used more fitting space is required
- 2) Tr 55x9 is standard, also available: double-pitch, INOX, left-handed, increased screw Tr 60x9 (only for the R-Version)
- 3) factor includes efficiency, ratio and 30% safety
- 4) for a 9 mm screw pitch
- 5) to calculate the length of our protective tube length SRO simply use our online configurator: [www.zimm.com](http://www.zimm.com)

**S 150 kN**  
**ZE-150-S | translating screw**

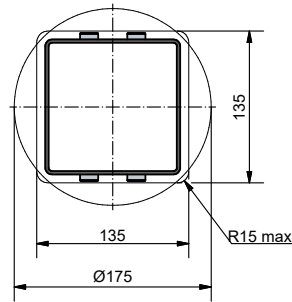
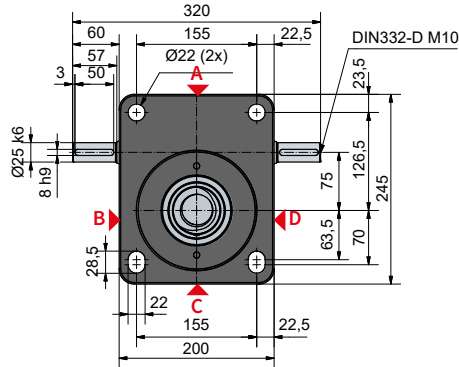
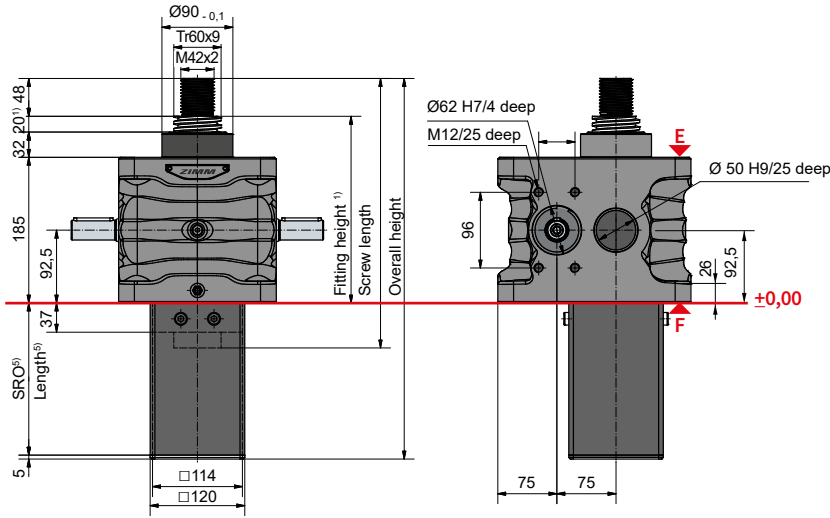

Opening for protective tube square or round



**Protective tube length SRO with Tr 60x9-Screw**

Without escape/rotation protection	87 + stroke
Escape/rotation protection	117 + stroke
Rotation protection, with limit switch set ESSET	149 + stroke

**Standard configuration**

Code	Gearbox (series)	Size	Version (variant)	Ratio	Screw	Stroke per drive shaft rotation
ZE-150-SN	ZE	150	S (translating screw)	N (normal) 9:1	Tr 60x9	1,00 mm
ZE-150-SL				L (low) 36:1		0,25 mm

**150 kN**

**Duty cycle thermal limit (S + R)**

**Ratio „N“ (9:1)**

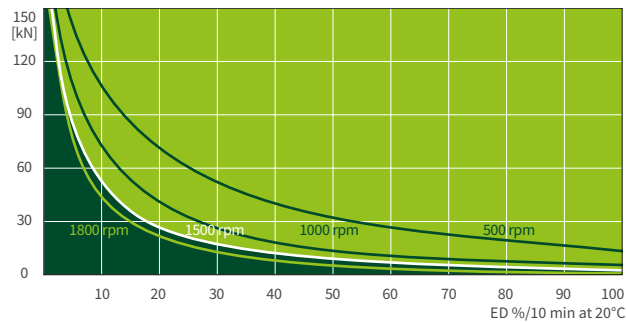

**Ratio „L“ (36:1)**

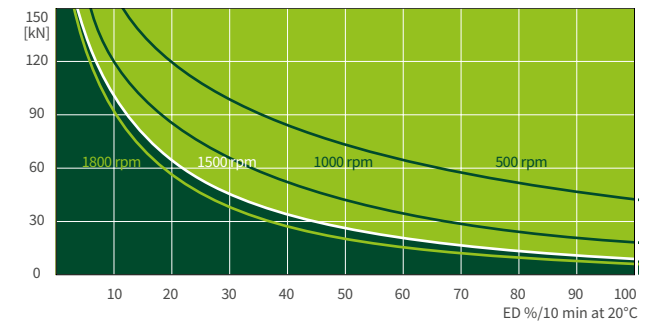

These curves are for guidance under standard industrial conditions (ambient temperature 20°C etc.) and correct maintenance (lubrication etc.). They are based on the ZIMM standard trapezoidal thread Tr 60x9. With the use of a ball screw, the operation cycles can be many times longer. In case you need an even longer duration or performance, you will find information about our ZE-H high performance gearboxes on page 70 and 71.



# R 150 kN

## ZE-150-R | rotating screw

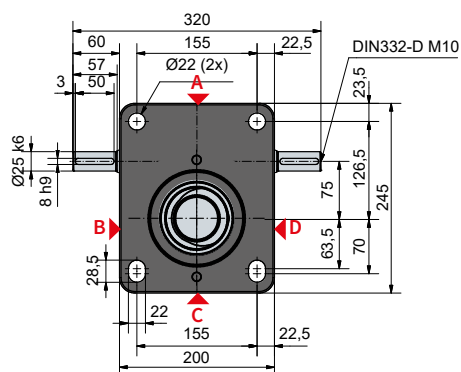
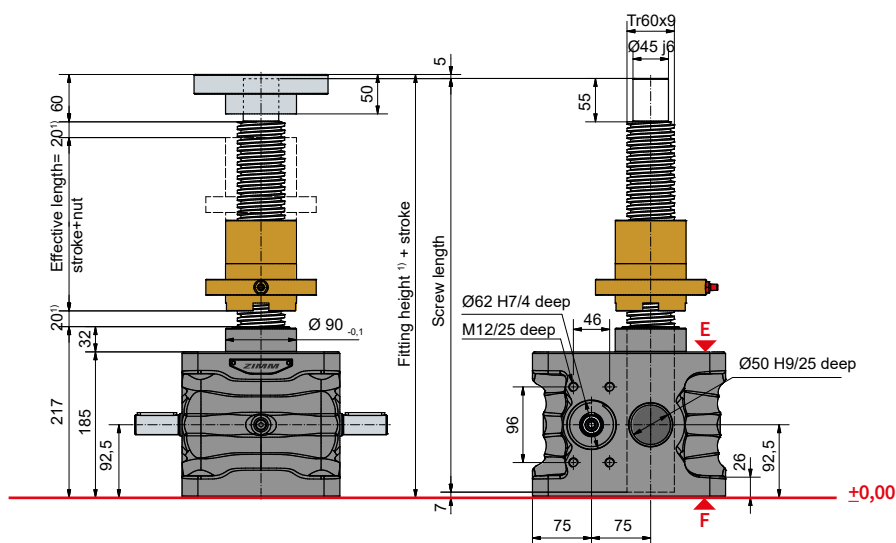

### Standard configuration

Code	Gearbox (series)	Size	Version (variant)	Ratio	Screw	Stroke per drive shaft rotation
ZE-150-RN	ZE	150	R (rotating screw)	N (normal) 9:1	Tr 60x9	1,00 mm
ZE-150-RL				L (low) 36:1		0,25 mm

### Technical data series ZE-150-S / ZE-150-R

max. compressive/tensile force, static:	150 kN (15 t)
max. compressive/tensile force, dyn:	see duty cycles curves
Input speed:	1500 rpm / max. 1800 rpm (depending on the load and duty cycle)
Screw size standard:	Tr 60x9 <sup>2)</sup>
Gear ratio:	9:1 (N) / 36:1 (L)
Housing material:	GGG, corrosion-resistant
Worm shaft:	steel, case-hardened, ground
Weight of screw jack body:	42 kg
Weight of screw/m:	19 kg
Gearbox lubrication:	synthetic fluid grease
Screw lubrication:	grease lubrication
Gearbox operating temperature:	max. 60°C, higher on request
Moment of inertia:	N: 7,92 kg cm <sup>2</sup> / L: 5,17 kg cm <sup>2</sup>
Input torque (at 1500 rpm):	max. 75,1 Nm (N) / max. 20,7 Nm (L)
Drive-through torque:	max. 540 Nm
Drive torque M <sub>G</sub> (Nm):	F (kN) x 0,75 <sup>3,4)</sup> (N-Normal) F (kN) x 0,25 <sup>3,4)</sup> (L-Low)
Breakaway torque:	Drive torque M <sub>G</sub> x 1,5

Make a plan to keep a safe distance of at least 20 mm between gearbox and nut or between nut and threaded end!

Detailed calculation of the fitting dimensions (bellows, screw, protective tube...) can be conveniently determined with our online configurator: [www.zimm.com](http://www.zimm.com)

#### Important information:

- 1) If a bellows, spiral spring or double pitch is used more fitting space is required
- 2) Tr 60x9 is standard, also available: double-pitch, INOX, left-handed, increased screw Tr 80x16 (only for the R-Version)
- 3) factor includes efficiency, ratio and 30% safety
- 4) for a 9 mm screw pitch
- 5) to calculate the length of our protective tube length SRO simply use our online configurator: [www.zimm.com](http://www.zimm.com)

**S** 200 kN  
**ZE-200-S** | translating screw

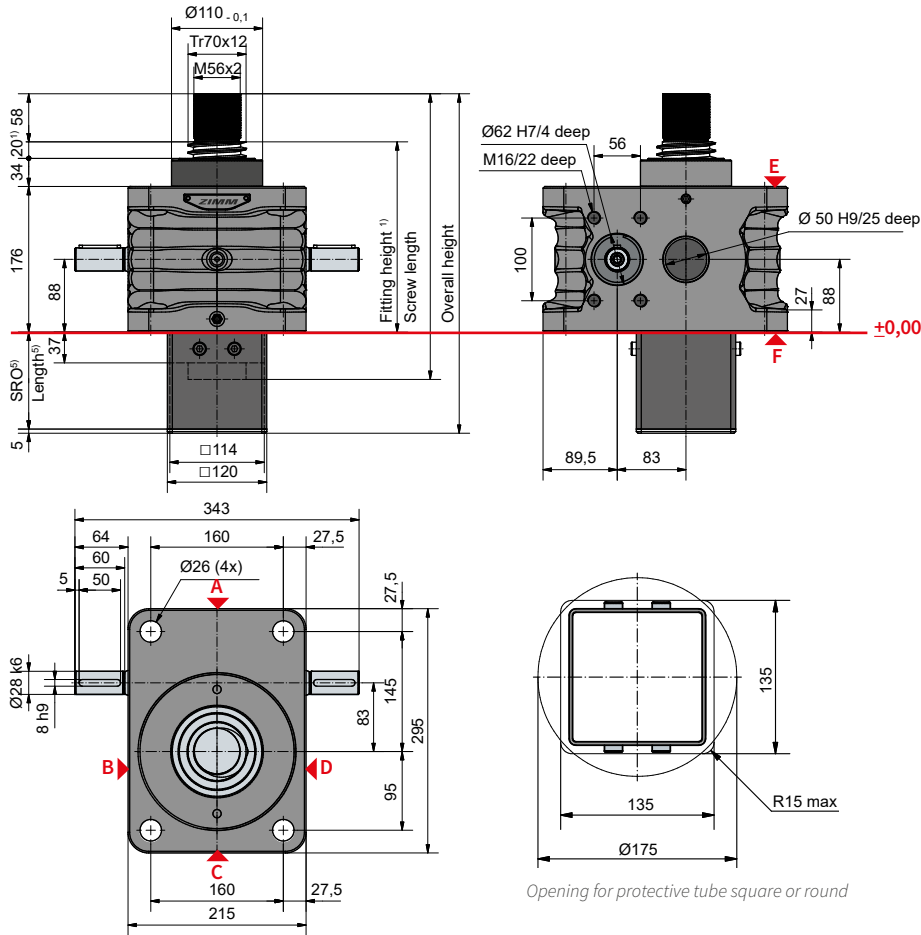

**Protective tube length SRO with Tr 70x12-Screw**

Without escape/rotation protection	87 + stroke
Escape/rotation protection	117 + stroke
Rotation protection, with limit switch set ESSET	149 + stroke

**Standard configuration**

Code	Gearbox (series)	Size	Version (variant)	Ratio	Screw	Stroke per drive shaft rotation
ZE-200-SN	ZE	200	S (translating screw)	N (normal) 8:1	Tr 70x12	1,50 mm
ZE-200-SL				L (low) 24:1		0,50 mm

**200 kN**

**Duty cycle thermal limit (S + R)**

Ratio „N“ (8:1)

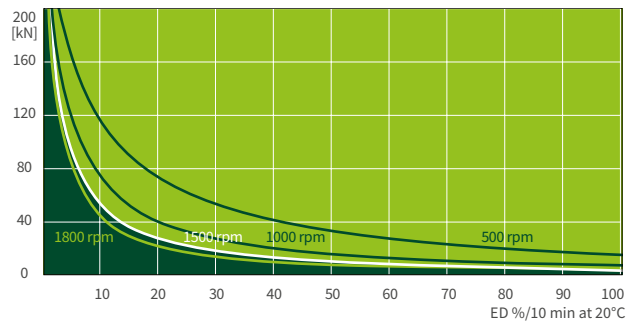

Ratio „L“ (24:1)

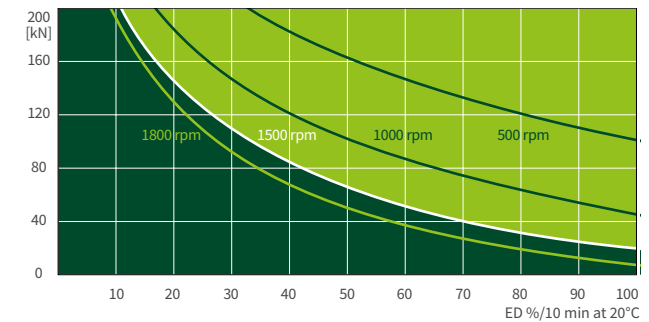

These curves are for guidance under standard industrial conditions (ambient temperature 20°C etc.) and correct maintenance (lubrication etc.). They are based on the ZIMM standard trapezoidal thread Tr 70x12. With the use of a ball screw, the operation cycles can be many times longer. In case you need an even longer duration or performance, you will find information about our ZE-H high performance gearboxes on page 70 and 71.





# R 200 kN

## ZE-200-R | rotating screw

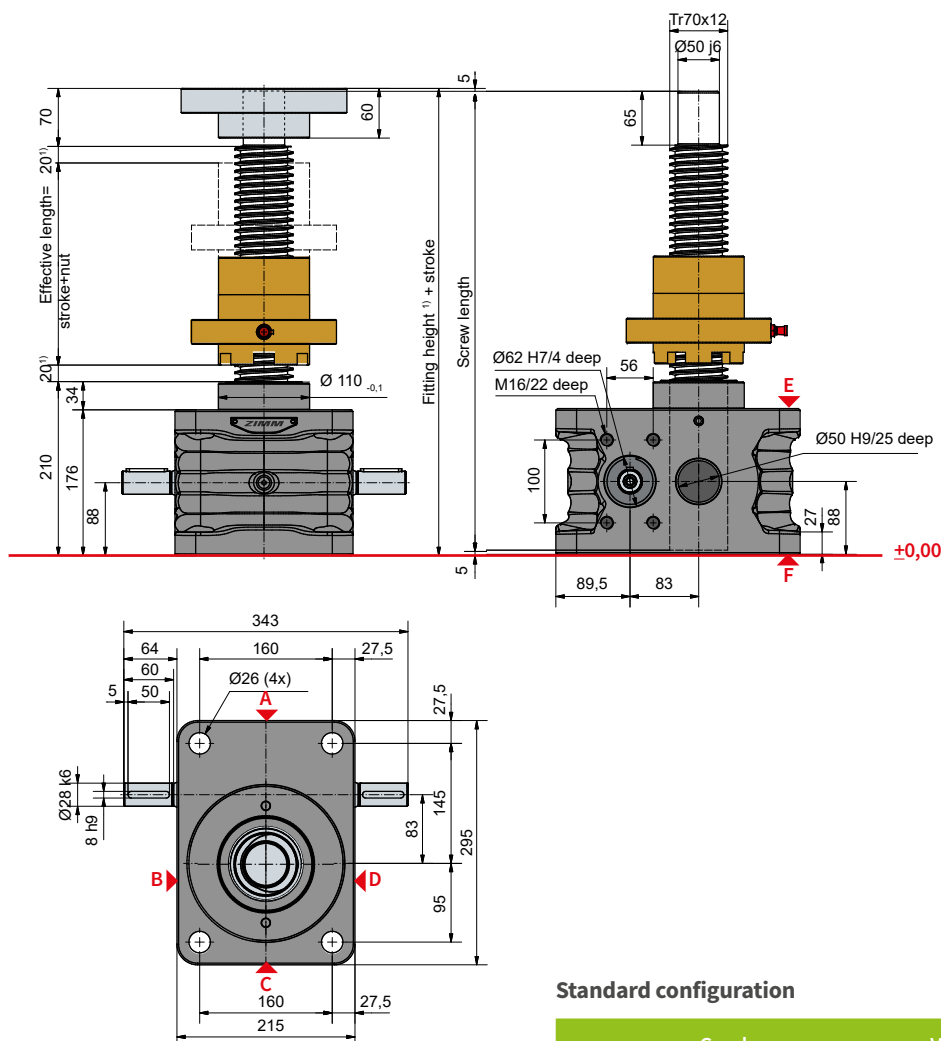

### Standard configuration

Code	Gearbox (series)	Size	Version (variant)	Ratio	Screw	Stroke per drive shaft rotation
ZE-200-RN	ZE	200	R (rotating screw)	N (normal) 8:1	Tr 70x12	1,50 mm
ZE-200-RL				L (low) 24:1		0,50 mm

### Technical data series ZE-200-S / ZE-200-R

max. compressive/tensile force, static:	200 kN (20 t)
max. compressive/tensile force, dyn:	see duty cycle curves
Input speed:	1500 rpm / max. 1800 rpm (depending on the load and duty cycle)
Screw size standard:	Tr 70x12 <sup>2)</sup>
Gear ratio:	8:1 (N) / 24:1 (L)
Housing material:	GGG, corrosion-resistant
Worm shaft:	steel, case-hardened, ground
Weight of screw jack body:	50 kg
Weight of screw/m:	25 kg
Gearbox lubrication:	synthetic fluid grease
Screw lubrication:	grease lubrication
Gearbox operating temperature:	max. 60°C, higher on request
Moment of inertia:	N: 11,5 kg cm <sup>2</sup> / L: 7,99 kg cm <sup>2</sup>
Input torque (at 1500 rpm):	max. 155,5 Nm (N) / max. 61 Nm (L)
Drive-through torque:	max. 700 Nm
Drive torque M <sub>G</sub> (Nm):	F (kN) x 1,1 <sup>3,4)</sup> (N-Normal) F (kN) x 0,45 <sup>3,4)</sup> (L-Low)
Breakaway torque:	Drive torque M <sub>G</sub> x 1,5

Make a plan to keep a safe distance of at least 20 mm between gearbox and nut or between nut and threaded end!

Detailed calculation of the fitting dimensions (bellows, screw, protective tube...) can be conveniently determined with our online configurator: [www.zimm.com](http://www.zimm.com)

#### Important information:

- 1) If a bellows, spiral spring or double pitch is used more fitting space is required
- 2) Tr 70x12 is standard, also available: double-pitch, INOX, left-handed
- 3) factor includes efficiency, ratio and 30% safety
- 4) for a 12 mm screw pitch
- 5) to calculate the length of our protective tube length SRO simply use our online configurator: [www.zimm.com](http://www.zimm.com)





# R 250 kN

## Z-250-R | rotating screw

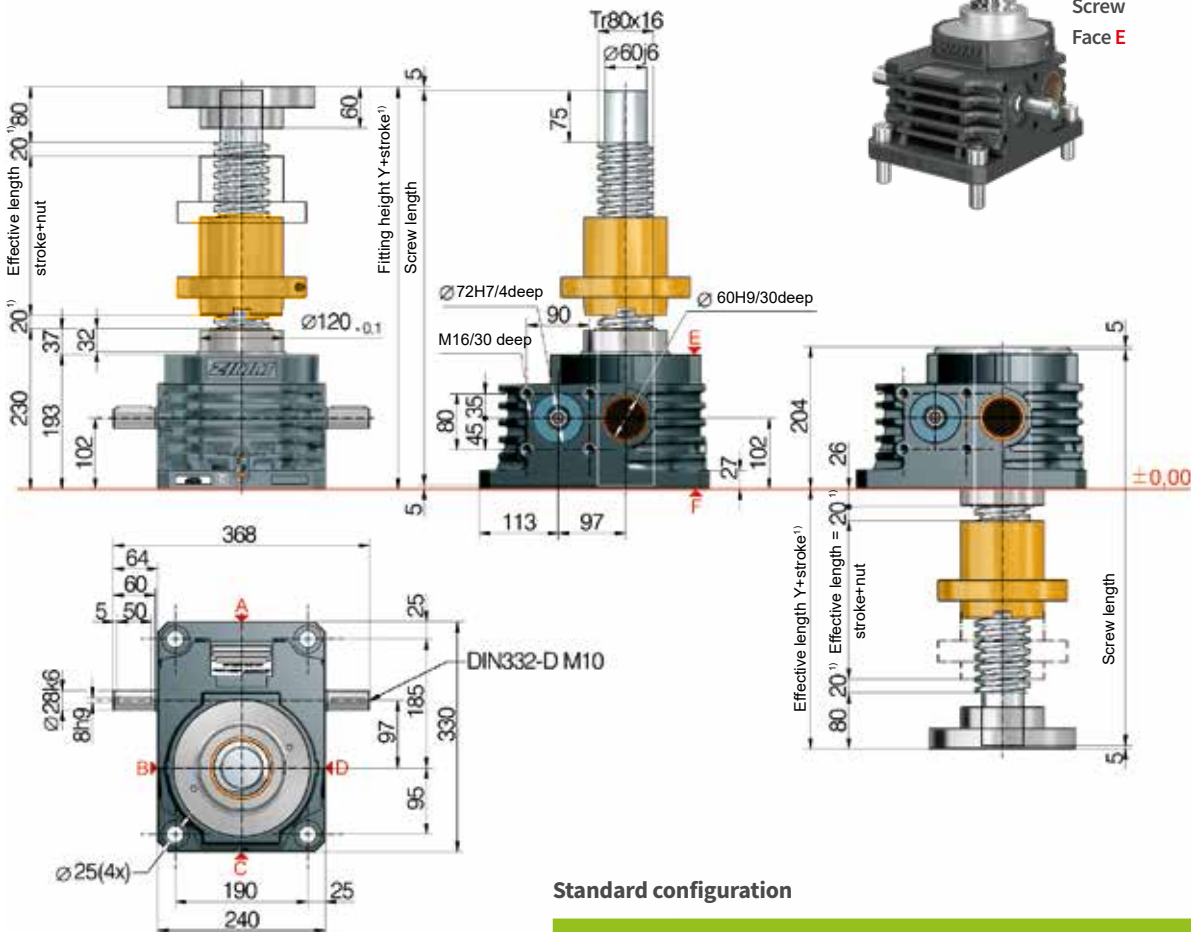

### Standard configuration

Code	Gearbox (series)	Size	Version (variant)	Ratio	Screw	Stroke per drive shaft rotation
Z-250-RN	Z	250	R (rotating screw)	N (normal) 10,66:1	Tr 80x16	1,50 mm
Z-250-RL				L (low) 32:1		0,50 mm

### Technical data series Z-250-S / Z-250-R

max. compressive/tensile force, static:	250 kN (25 t)
max. compressive/tensile force, dyn.:	see duty cycle curves
Input speed:	1500 rpm / max. 1800 rpm (depending on the load and duty cycle)
Screw size standard:	Tr 80x16 <sup>2)</sup>
Gear ratio:	10,66:1 (N) / 32:1 (L)
Housing material:	GGG-50, corrosion-resistant
Worm shaft:	steel, case-hardened, ground
Weight of screw jack body:	59 kg
Weight of screw/m:	32 kg
Gearbox lubrication:	synthetic gear oil
Screw lubrication:	grease lubrication
Gearbox operating temperature:	max. 60°C, higher on request
Moment of inertia:	N: 53,8 kg cm <sup>2</sup> / L: 22,0 kg cm <sup>2</sup>
Input torque (at 1500 rpm):	max. 152 Nm (N) / max. 41,4 Nm (L)
Drive-through torque:	max. 770 Nm
Drive torque M <sub>G</sub> (Nm):	F (kN) x 0,94 <sup>3,4)</sup> (N-Normal) F (kN) x 0,37 <sup>3,4)</sup> (L-Low)
Breakaway torque:	Drive torque M <sub>G</sub> x 1,5

Make a plan to keep a safe distance of at least 20 mm between gearbox and nut or between nut and threaded end!

Detailed calculation of the fitting dimensions (bellows, screw, protective tube...) can be conveniently determined with our online configurator: [www.zimm.com](http://www.zimm.com)

#### Important information:

- 1) If a bellows, spiral spring or double pitch is used more fitting space is required
- 2) Tr 80x16 is standard, also available: double-pitch, INOX, left-handed, increased screw Tr 100x16 (only for the R-Version)
- 3) factor includes efficiency, ratio and 30% safety
- 4) for a 16 mm screw pitch
- 5) to calculate the length of our protective tube length SRO simply use our online configurator: [www.zimm.com](http://www.zimm.com)





# R 350 kN

## Z-350-R | rotating screw

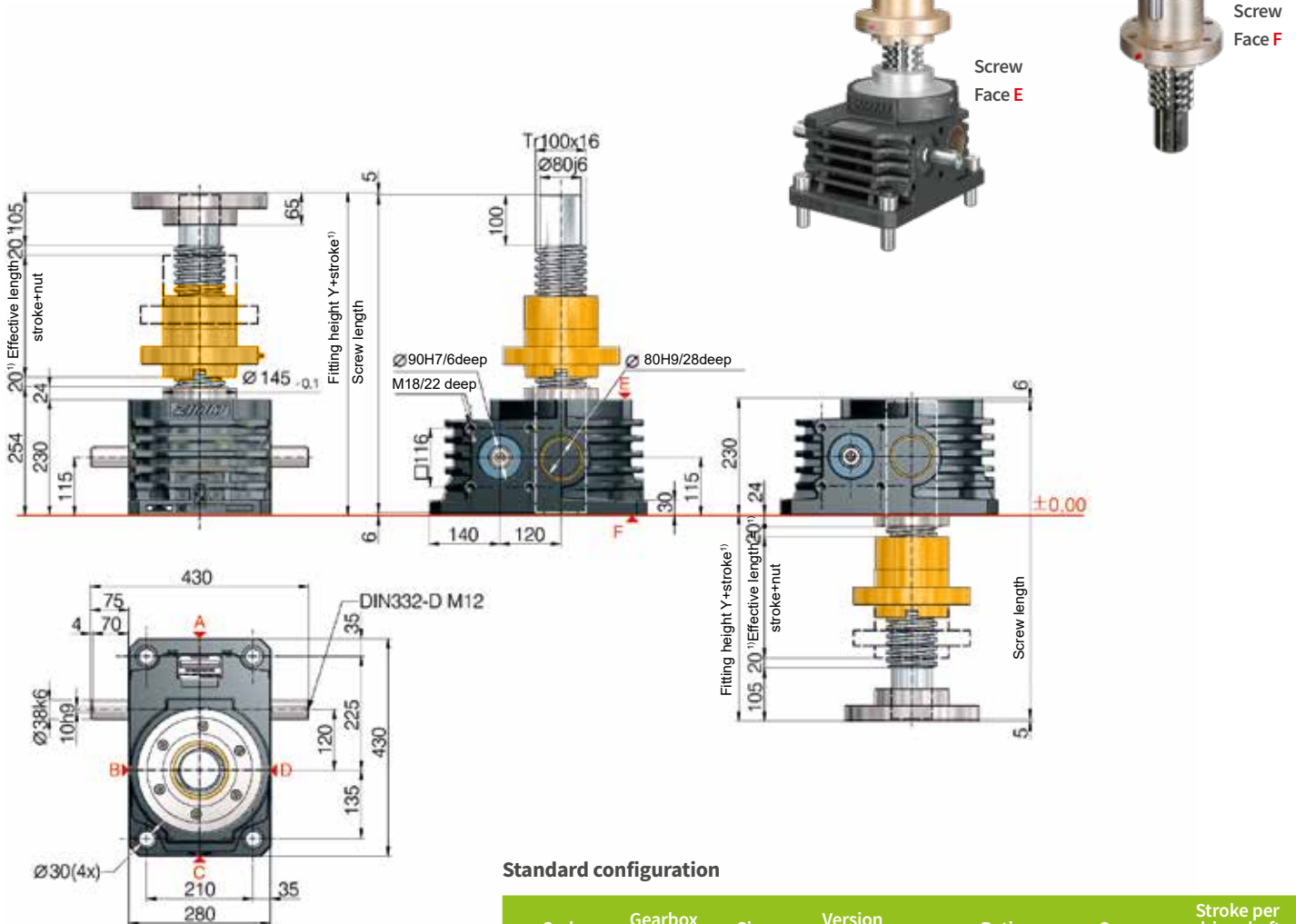

### Standard configuration

Code	Gearbox (series)	Size	Version (variant)	Ratio	Screw	Stroke per drive shaft rotation
Z-350-RN	Z	350	R (rotating screw)	N (normal) 10,66:1	Tr 100x16	1,50 mm
Z-350-RL				L (low) 32:1		0,50 mm

### Technical data series Z-350-S / Z-350-R

max. compressive/tensile force, static:	350 kN (35 t)
max. compressive/tensile force, dyn:	see duty cycle curves
Input speed:	1000 rpm / max. 1200 rpm (depending on the load and duty cycle)
Screw size standard:	Tr 100x16 <sup>2)</sup>
Gear ratio:	10,66:1 (N) / 32:1 (L)
Housing material:	GGG-50, corrosion-resistant
Worm shaft:	steel, case-hardened, ground
Weight of screw jack body:	112 kg
Weight of screw/m:	52 kg
Gearbox lubrication:	synthetic gear oil
Screw lubrication:	grease lubrication
Gearbox operating temperature:	max. 60°C, higher on request
Moment of inertia:	N: 148,9 kg cm <sup>2</sup> / L: 66,1 kg cm <sup>2</sup>
Input torque (at 1000 rpm):	max. 265 Nm (N) / max. 100 Nm (L)
Drive-through torque:	max. 1800 Nm
Drive torque M <sub>G</sub> (Nm):	F (kN) x 1,09 <sup>3,4)</sup> (N-Normal) F (kN) x 0,42 <sup>3,4)</sup> (L-Low)
Breakaway torque:	Drive torque M <sub>G</sub> x 1,5

Make a plan to keep a safe distance of at least 20 mm between gearbox and nut or between nut and threaded end!

Detailed calculation of the fitting dimensions (bellows, screw, protective tube...) can be conveniently determined with our online configurator: [www.zimm.com](http://www.zimm.com)

#### Important information:

- 1) If a bellows, spiral spring or double pitch is used more fitting space is required
- 2) Tr 100x16 is standard, also available: double-pitch, INOX, left-handed, increased screw Tr 120x16 (only for the R-Version)
- 3) factor includes efficiency, ratio and 30% safety
- 4) for a 16 mm screw pitch
- 5) to calculate the length of our protective tube length SRO simply use our online configurator: [www.zimm.com](http://www.zimm.com)

**S** 500 kN  
Z-500-S | translating screw

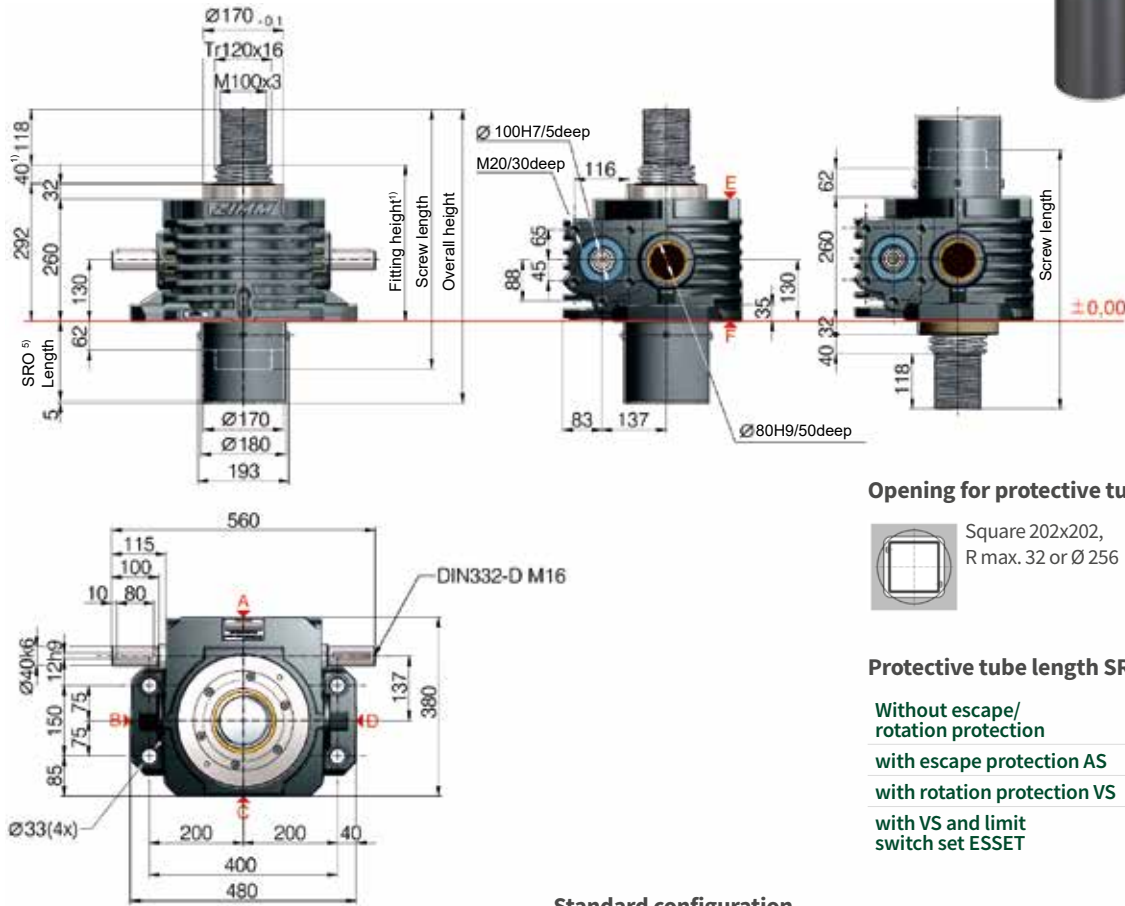

**Opening for protective tube SRO**

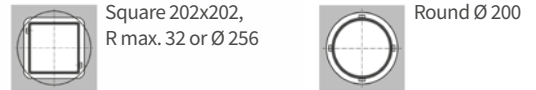

**Protective tube length SRO with Tr 120x16-Screw**

Without escape/rotation protection	157 + stroke	Ø 180
with escape protection AS	197 + stroke	Ø 180
with rotation protection VS	197 + stroke	□ 180 x 180
with VS and limit switch set ESSET	197 + stroke	□ 180 x 180

**Standard configuration**

Code	Gearbox (series)	Size	Version (variant)	Ratio	Screw	Stroke per drive shaft rotation
Z-500-SN	Z	500	S (translating screw)	N (normal) 10,66:1	Tr 120x16	1,50 mm
Z-500-SL				L (low) 32:1		0,50 mm

**500 kN**

**Duty cycle thermal limit (S + R)**

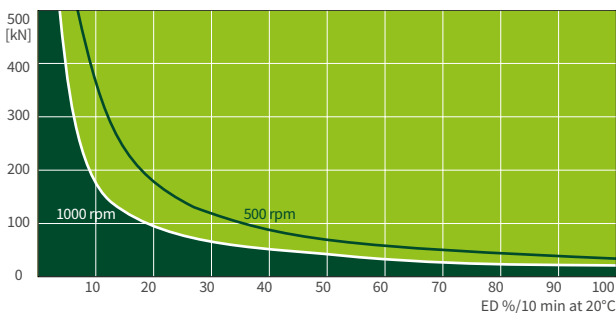

These curves are for guidance under standard industrial conditions (ambient temperature 20°C etc.) and correct maintenance (lubrication etc.). They are based on the ZIMM standard trapezoidal thread Tr 120x16. With the use of a ball screw, the operation cycles can be many times longer.

**Screw jack mounting Z-Series**

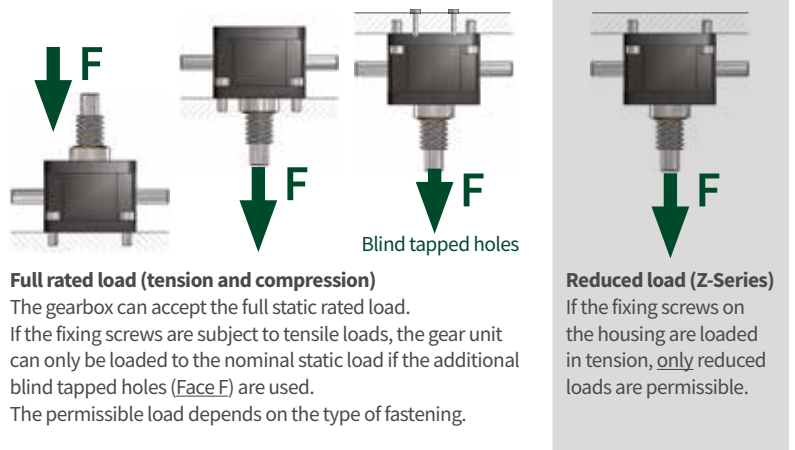

**Full rated load (tension and compression)**

The gearbox can accept the full static rated load. If the fixing screws are subject to tensile loads, the gear unit can only be loaded to the nominal static load if the additional blind tapped holes (Face F) are used. The permissible load depends on the type of fastening.

**Reduced load (Z-Series)**

If the fixing screws on the housing are loaded in tension, only reduced loads are permissible.



**S 750 kN**  
**Z-750-S | translating screw**

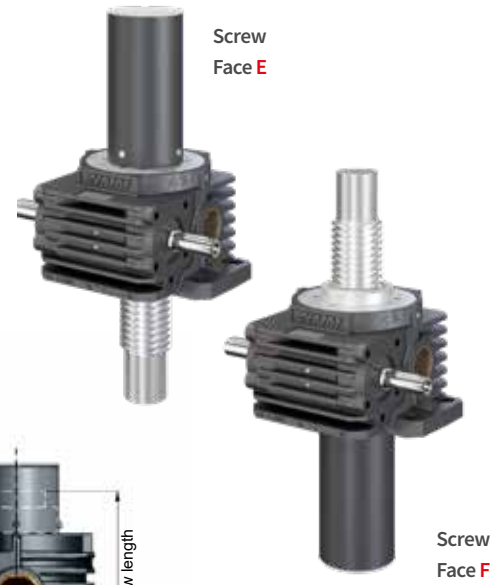
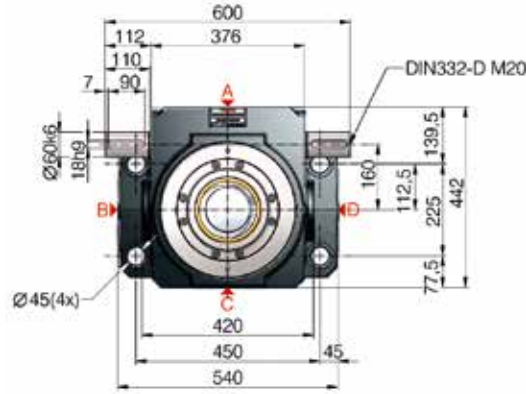
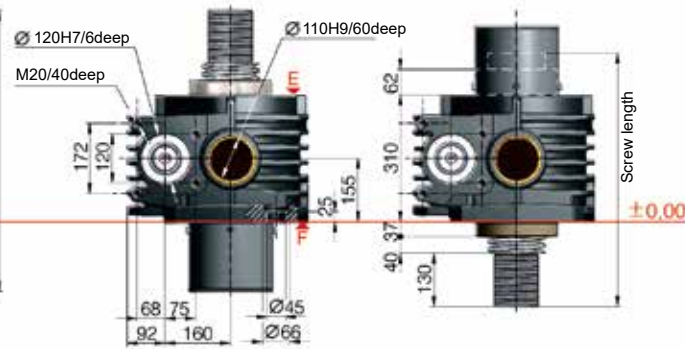
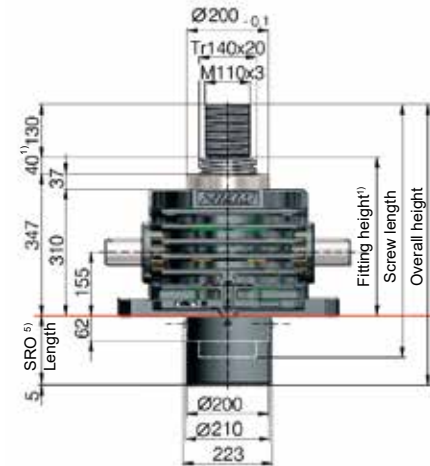

**Opening for protective tube**

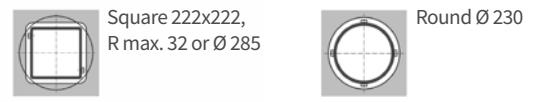

**Protective tube SRO with Tr 140x20-Screw**

<b>Without escape/rotation protection</b>	157 + stroke	Ø 210
<b>with escape protection AS</b>	197 + stroke	Ø 210
<b>with rotation protection VS</b>	197 + stroke	□200 x 200
<b>with VS and limit switch set ESSET</b>	205 + stroke	□200 x 200

**Standard configuration**

Code	Gearbox (series)	Size	Version (variant)	Ratio	Screw	Stroke per drive shaft rotation
Z-750-SN	Z	750	S (translating screw)	N (normal) 13,33:1	Tr 140x20	1,50 mm
Z-750-SL				L (low) 40:1		0,50 mm

**750 kN**

**Duty cycle thermal limit (S + R)**

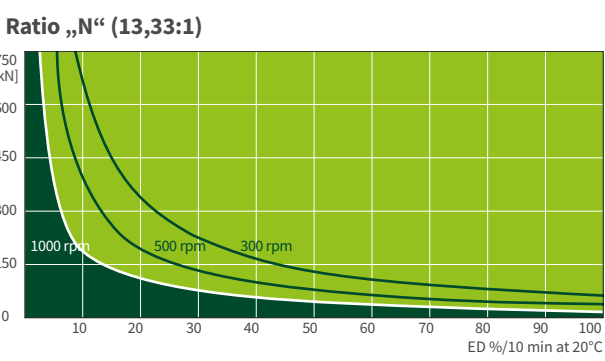

These curves are for guidance under standard industrial conditions (ambient temperature 20°C etc.) and correct maintenance (lubrication etc.). They are based on the ZIMM standard trapezoidal thread Tr 140x20. With the use of a ball screw, the operation cycles can be many times longer.

**Screw jack mounting Z-Series**

Diagrams showing screw jack mounting configurations: Full rated load (tension and compression) and Reduced load (Z-Series). Labels include F, Blind tapped holes, Full rated load (tension and compression), and Reduced load (Z-Series).

**Full rated load (tension and compression)**  
The gearbox can accept the full static rated load. If the fixing screws are subject to tensile loads, the gear unit can only be loaded to the nominal static load if the additional blind tapped holes (Face F) are used. The permissible load depends on the type of fastening.

**Reduced load (Z-Series)**  
If the fixing screws on the housing are loaded in tension, only reduced loads are permissible.





**S** 1000 kN  
**Z-1000-S** | translating screw

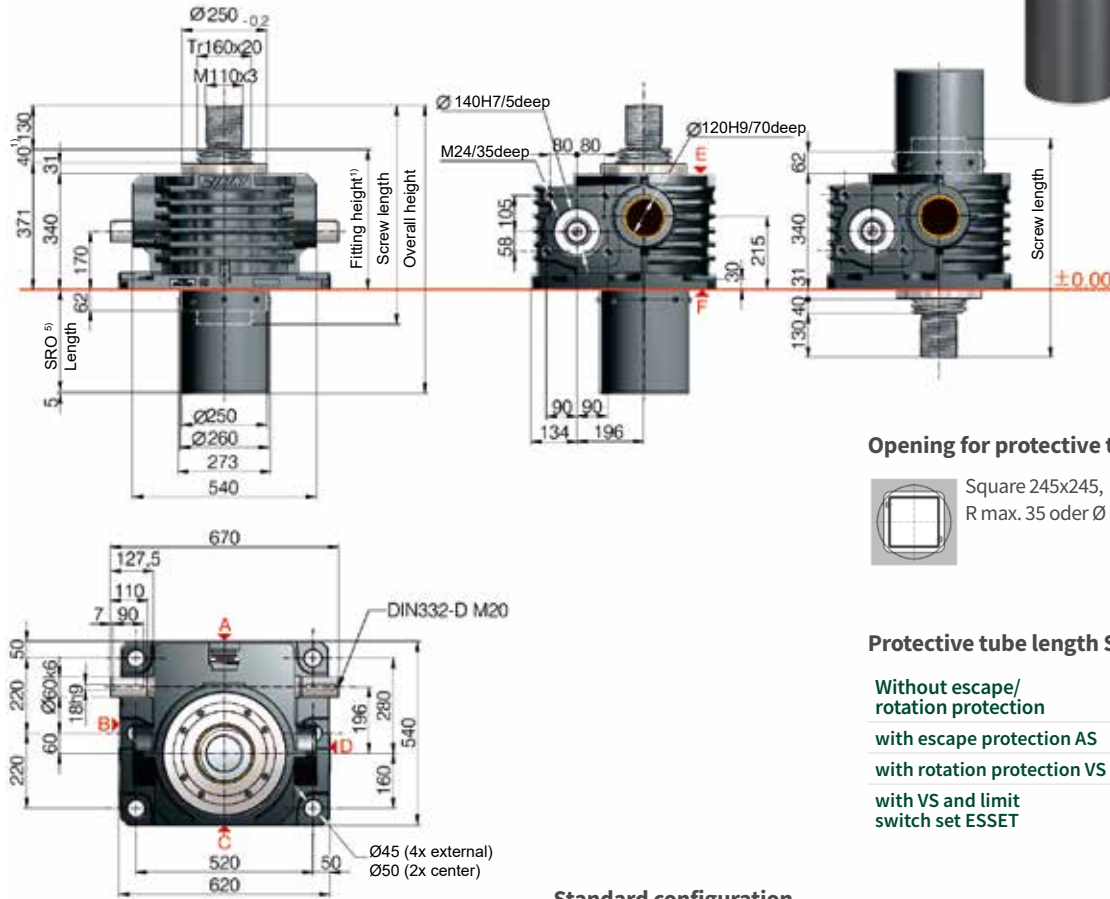

**Opening for protective tube SRO**

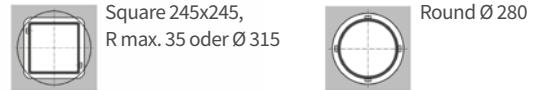

**Protective tube length SRO with Tr 160x20-Screw**

Without escape/rotation protection	157 + stroke	Ø 260
with escape protection AS	197 + stroke	Ø 260
with rotation protection VS	197 + stroke	□220 x 220
with VS and limit switch set ESSET	205 + stroke	□220 x 220

**Standard configuration**

Code	Gearbox (series)	Size	Version (variant)	Ratio	Screw	Stroke per drive shaft rotation
Z-1000-SN	Z	1000	S (translating screw)	N (normal) 13,33:1	Tr 160x20	1,50 mm
Z-1000-SL				L (low) 40:1		0,50 mm

# 1000 kN

**Duty cycle thermal limit (S + R)**

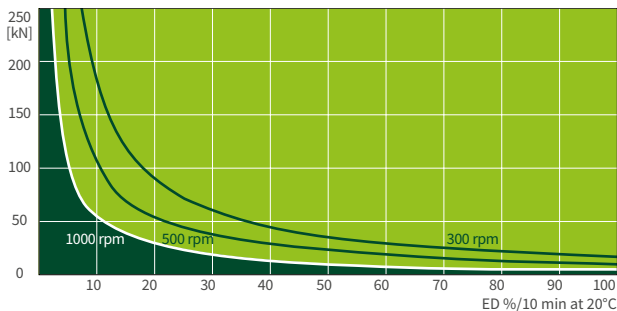

These curves are for guidance under standard industrial conditions (ambient temperature 20°C etc.) and correct maintenance (lubrication etc.). They are based on the ZIMM standard trapezoidal thread Tr 160x20. With the use of a ball screw, the operation cycles can be many times longer.

**Screw jack mounting Z-Series**

**Full rated load (tension and compression)**  
 The gearbox can accept the full static rated load. If the fixing screws are subject to tensile loads, the gear unit can only be loaded to the nominal static load if the additional blind tapped holes (Face F) are used. The permissible load depends on the type of fastening.

**Reduced load (Z-Series)**  
 If the fixing screws on the housing are loaded in tension, only reduced loads are permissible.



# R 1000 kN

## Z-1000-R | rotating screw

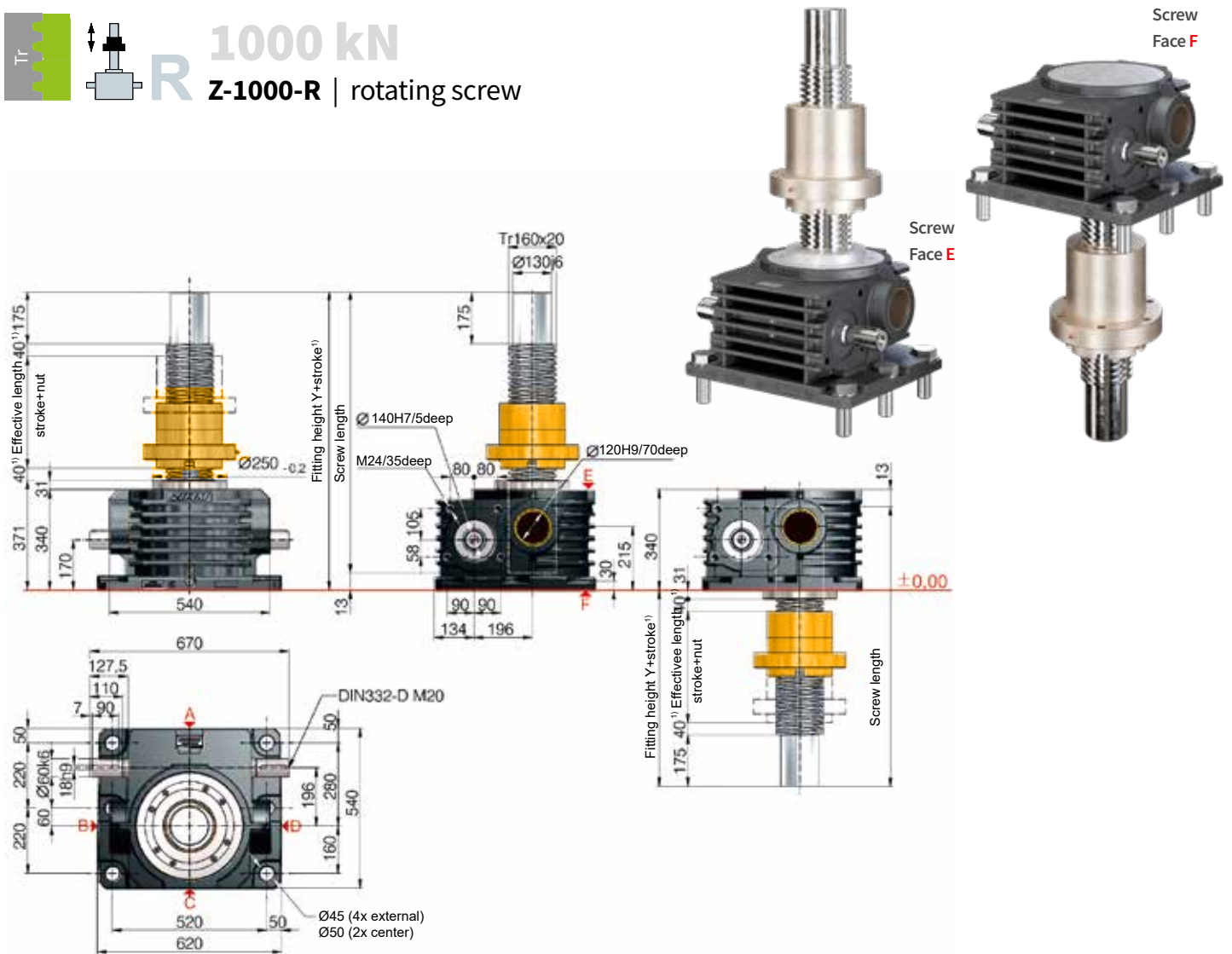

### Standard configuration

Code	Gearbox (series)	Size	Version (variant)	Ratio	Screw	Stroke per drive shaft rotation
Z-1000-RN	Z	1000	R (rotating screw)	N (normal) 13,33:1	Tr 160x20	1,50 mm
Z-1000-RL				L (low) 40:1		0,50 mm

### Technical data series Z-1000-S / Z-1000-R

max. compressive/tensile force, static:	1000 kN (100 t)
max. compressive/tensile force, dyn.:	see duty cycle curves
Input speed:	1000 rpm / max. 1000 rpm (depending on the load and duty cycle)
Screw size standard:	Tr 160x20 <sup>2)</sup>
Gear ratio:	13,33:1 (N) / 40:1 (L)
Housing material:	GGG-50, corrosion-resistant
Worm shaft:	steel, case-hardened, ground
Weight of screw jack body:	408 kg
Weight of screw/m:	139 kg
Gearbox lubrication:	synthetic gear oil
Screw lubrication:	grease lubrication
Gearbox operating temperature:	max. 60°C, higher on request
Moment of inertia:	N: 1058,2 kg cm <sup>2</sup> / L: 459,2 kg cm <sup>2</sup>
Input torque (at 1000 rpm):	max. 680 Nm (N) / max. 450 Nm (L)
Drive-through torque:	max. 4570 Nm
Drive torque M <sub>G</sub> (Nm):	F (kN) x 1,32 <sup>3,4)</sup> (N-Normal) F (kN) x 0,51 <sup>3,4)</sup> (L-Low)
Breakaway torque:	Drive torque M <sub>G</sub> x 1,5

Make a plan to keep a safe distance of at least 40 mm between gearbox and nut or between nut and threaded end!

Detailed calculation of the fitting dimensions (bellows, screw, protective tube...) can be conveniently determined with our online configurator: [www.zimm.com](http://www.zimm.com)

#### Important information:

- 1) If a bellows, spiral spring or double pitch is used more fitting space is required
- 2) Tr 160x20 is standard, also available: double-pitch, INOX, left-handed, increased screw Tr 190x24 (only for the R-Version)
- 3) factor includes efficiency, ratio and 30% safety
- 4) for a 20 mm screw pitch
- 5) to calculate the length of our protective tube length SRO simply use our online configurator: [www.zimm.com](http://www.zimm.com)

# SECURITY AND INSPECTION

**Avoid downtime & protect people**

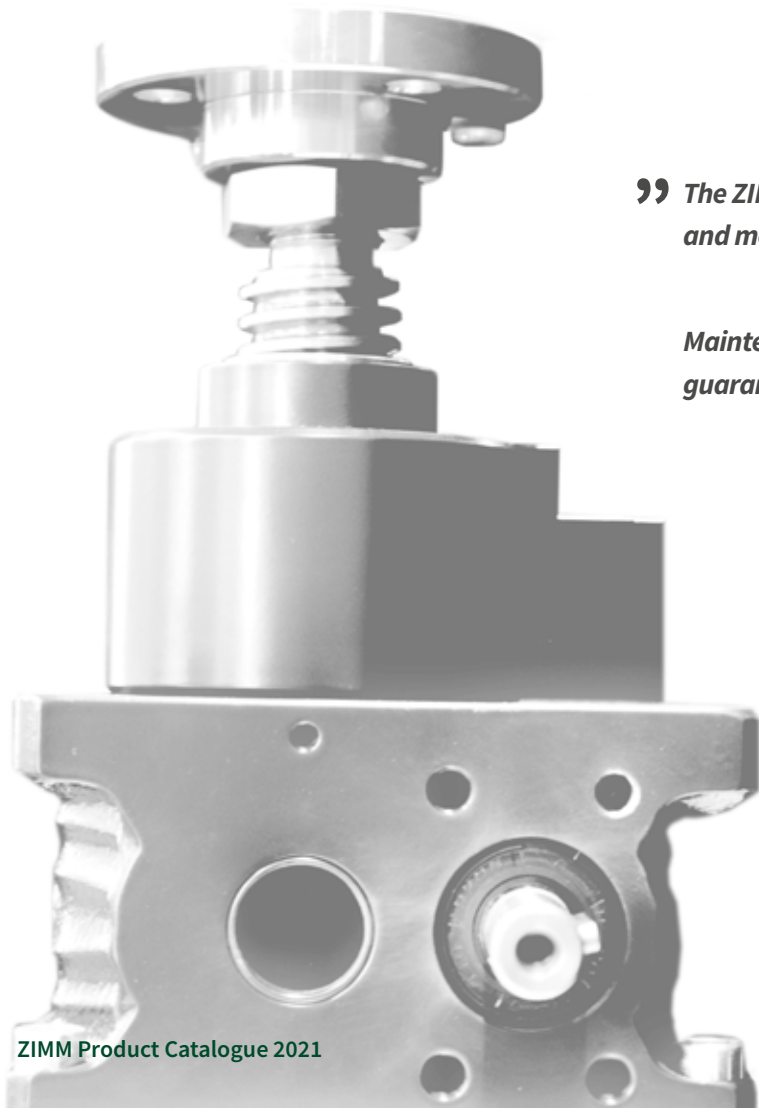

” *The ZIMM SIFA-S monitoring system saves you time and money in the long term.*

*Maintenance or replacement is virtually guaranteed by monitoring wear.*

**Peter Gridling | Sales Manager**



# Safety nut

ZE-SIFA, Z-SIFA | translating & rotating screw



Tr SIFA-S visual



Tr SIFA-S electrical



Tr SIFA-R visual



Tr SIFA-R electrical

## Technical data

### Wear:

Once the wear exceeds max. 25% of the screw pitch, the load nut (R) or the gearbox (S) must be replaced.

### Monitoring:

Wear and thread play should be checked and documented at regular intervals (depending on the duty cycle). This allows the fitting of replacement parts to be planned ahead, reducing unscheduled system downtime.

### Electrical monitoring:

Electrical monitoring gives a signal when wear reaches approx. 25%. This signal can be displayed immediately at a central control point. Replacement of the worn parts can then be scheduled.

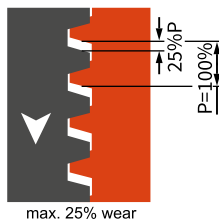

max. 25% wear

A safety nut is designed for use where stripping and break up of the thread could cause a hazard to persons.

A safety nut can also provide protection for other equipment against the consequences of machine failures and downtimes.

Screw jacks Tr $\emptyset$ xP	Pitch P mm	max. permissible wear/ thread play* (25% of P) mm
Tr16x4, Tr18x4, Tr20x4	4	1
Tr30x6	6	1,5
Tr40x7	7	1,75
Tr55x9, Tr60x9	9	2,25
Tr70x12	12	3
Tr80x16, Tr100x16, Tr120x16	16	4
Tr140x20, Tr160x20	20	5

\*Identical for double pitch screws (same thread flank thickness)

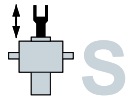

**Safety nut**  
**SIFA-S** | translating screw

# COMPRESSIVE AND TENSILE

The SIFA-S operates equally in both compressive & tensile directions of loading!



visual SIFA monitoring

electrical SIFA monitoring

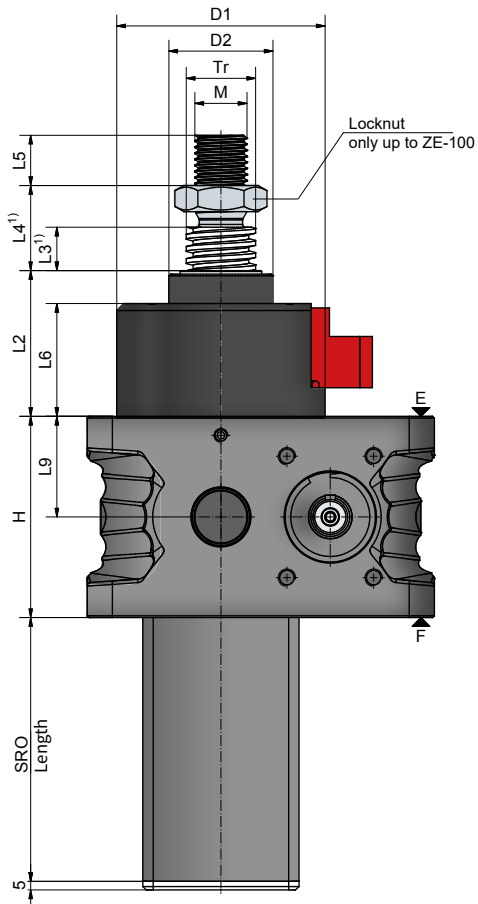

Locknut only up to ZE-100

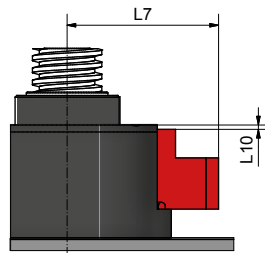

visual SIFA monitoring

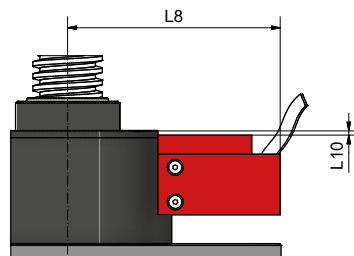

electrical SIFA monitoring

**Function:**

The load is borne by the worm wheel via the screw. If the worm wheel screw thread wears through, the SIFA restrains the screw. The load remains supported.

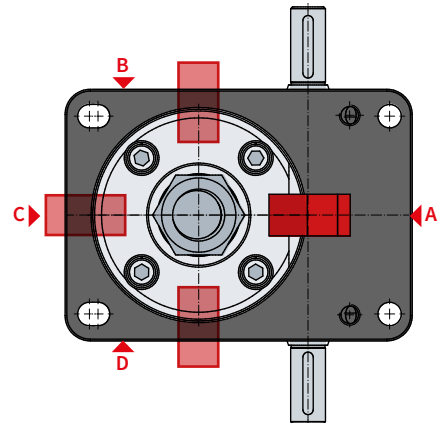

Screw jacks	Stroke travel/rev.		Tr-Thread	H	D1	D2	L2	L3 <sup>1)</sup>	L4 <sup>1)</sup>	L5	L6	L7	L8	L9	L10	M
	SN	SL														
ZE-10 <sup>4)</sup>	1	0,25	20x4	74	81	39	74	10	22	20	58	72	108	37	1	M14
ZE-25 <sup>4)</sup>	1	0,25	30x6	82	92	46	76	10	26	22	59	79	114	41	1	M20
ZE-35	1	0,25	40x7	100	100	60	80	10	34	29	61	82	117	50	1	M30
ZE-50 <sup>4)</sup>	1	0,25	40x7	116	120	60	84	10	34	29	65	88	123	58	1	M30
ZE-100 <sup>4)</sup>	1	0,25	55x9	160	135	85	103	20	48	48	73	95	130	80	9	M36
ZE-150 <sup>4)</sup>	1	0,25	60x9	185	161	90	113	20	20	48	81	107	141	92,5	6	M42x2
Z-250	1,5	0,50	80x16	193	210	120	166 <sup>2)</sup>	20	20	58	139 <sup>2)</sup>	117	152	91	13	M56x2
Z-350	1,5	0,50	100x16	230	276	145	179 <sup>3)</sup>	20	20	78	155	139	174	115	30	M72x3

up to Z-1000 on request

1) Detailed calculation of the fitting dimensions (bellows, screw, protective tube...) can be conveniently determined with our online configurator: [www.zimm.com](http://www.zimm.com)

2) Screw Face F: L2 = 181, L6 = 148

3) Screw Face F: L2 = 207

4) SIFA values also valid for the GSZ series



# Safety nut

## SIFA-S | monitoring

### Standard

If the version used has no visual or electrical monitoring, the dimension A must be measured and documented when new, then regularly checked and documented frequently.

That way the user can detect the wear by measuring by hand from time to time.

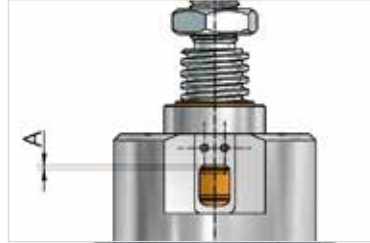

### Visual

#### Monitoring

Wear should be checked and documented at regular intervals. This allows the fitting operation for replacement to be planned in good time so as to avoid system downtime..

**OKAY**   
Wear still <25% of P

**CAUTION!**   
max. permissible wear reached - [Replace the gearbox](#)

**STOP!**   
Wear >25% or thread already worn through  
**Stop operation immediately!**

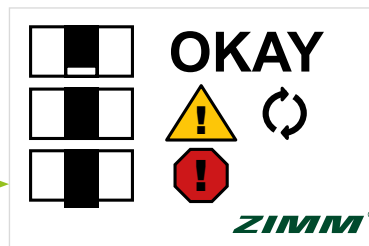

### Electrical

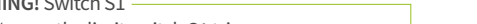
**WARNING!** Switch S1   
At 25% wear the limit switch S1 trips. The customer must detect this signal. This enables substitution to be planned well in advance and therefore prevents any unnecessary downtime.

**STOP!** Switch S2   
If after the first signal operation of the jack continues, the nut will continue to wear until the thread is worn through.

When the thread is worn through, the safety nut takes the load. The limit switch S2 trips.

The customer must detect this signal and stop the system.

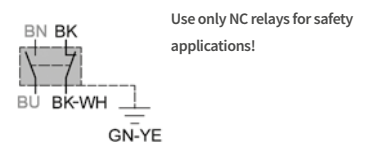
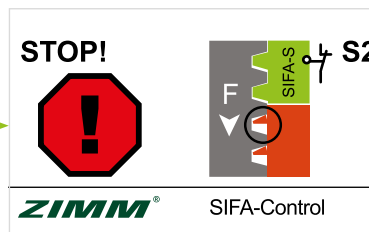
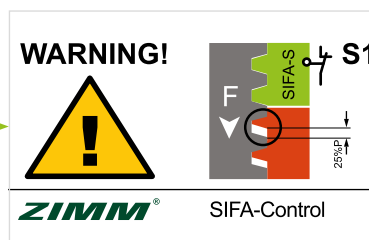

### Ordering example:

**ZE-35-SN-SIFA-OP-A**

Version   
SN or SL

Monitoring 

NO: without any monitoring

OP: visual monitoring

EL: electrical monitoring (wear, thread stripping)

Position 

A (Standard), B, C or D

(can also subsequently be rotated steplessly through 360°)



# Safety nut

## SIFA-R | rotating screw

**Function:**

The load is borne by the duplex nut. The safety nut runs alongside the duplex nut, bearing no load. If the nut thread is worn through due to wear, the SIFA takes the load.

**Direction of loading, tensile or compressive**

A drawing showing the direction of loading is necessary in order to ensure the safety function. The SIFA-R operates in only one direction of loading.



SIFA without monitoring

electrical SIFA monitoring

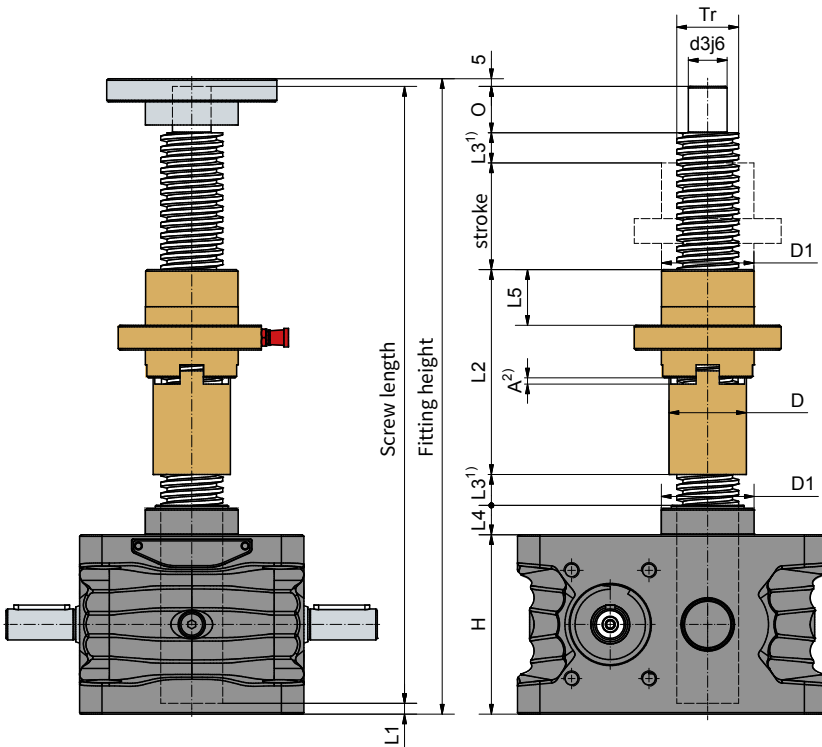

**Correct mounting side SIFA-R**

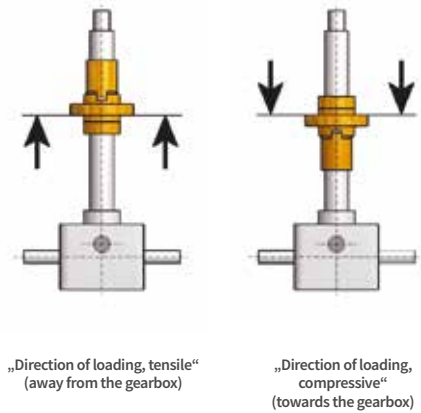

Screw jacks	Tr-Thread	H	D1	D	d3j6	O	L1	L2	L3 <sup>1)</sup>	L4	L5	A <sup>2)</sup> ca.
GSZ-2	16x4	50	26	22	10	12	3	70	10	11	20	3
ZE-5 <sup>3)</sup>	18x4	62	29	24	12	15	8	70	10	12	20	3
ZE-10 <sup>3)</sup>	20x4	74	39	28	15	20	8	84	10	16	20	3
ZE-25 <sup>3)</sup>	30x6	82	46	38	20	25	5	95	10	17	23	4
ZE-35	40x7	100	60	50	25	30	7	133	10	19	36	4
ZE-50 <sup>3)</sup>	40x7	116	60	50	25	30	7	133	10	19	36	4
ZE-100 <sup>3)</sup>	55x9	160	85	65	40	45	8	173	20	30	54	6
ZE-150 <sup>3)</sup>	60x9	185	90	70	45	55	7	211	20	32	75	6
ZE-200	70x12	176	110	95	50	65	5	233	20	34	75	7
Z-250	80x16	193	120	100	60	75	5	250	20	37	85	9
Z-350	100x16	230	150	120	80	100	6	270	20	24	100	9
Z-500	120x16	260	170	135	95	120	6	303	40	32	110	9
Z-750	140x20	310	200	170	100	120	10	365	40	37	140	12
Z-1000	160x20	340	250	190	130	175	13	500	40	32	210	12

1) Detailed calculation of the fitting dimensions (bellows, screw, protective tube...) can be conveniently determined with our online configurator: [www.zimm.com](http://www.zimm.com)

3) SIFA values also valid for the GSZ series

2) Original setting, must be measured and documented by the customer, and referred to when checking



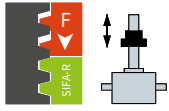

# R Monitoring with safety nut

## SIFA-R | rotating screw

### Visual monitoring

Dimension A is approx. the original setting.  
Dimension A must be measured and documented by the customer, and referred to when checking.

This enables substitution to be planned well in advance and therefore prevents any unnecessary downtime.

When the thread is worn through, take the system out of service immediately.

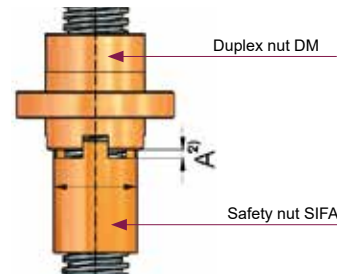

Gearbox TrØxP	Pitch P mm	max. permissible wear/ thread play* (25% of P) mm
Tr16x4 <sup>1)</sup> , Tr18x4 <sup>1)</sup> , Tr20x4 <sup>1)</sup>	4	1
Tr30x6 <sup>1)</sup>	6	1,5
Tr40x7 <sup>1)</sup>	7	1,75
Tr55x9 <sup>1)</sup> , Tr60x9	9	2,25
Tr70x12	12	3
Tr80x16	16	4

\*Identical for double pitch screw (same thread flank thickness)

1) SIFA values also valid for the GSZ series

### Electrical monitoring

The initiator must be set so that it switches off when the load nut reaches 25% of the wear.

This enables a replacement to be planned well in advance and therefore prevents any unnecessary downtime.

When the thread is worn through, take the system out of service immediately.

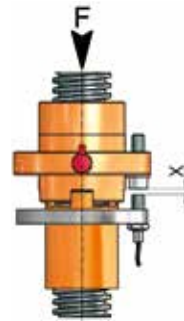
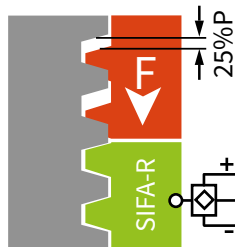

Ordering example:

**ZE-35-RL-SIFA-OP**

Version

RN or RL

Monitoring

OP: Visual monitoring

EL: Electrical monitoring (wear, thread stripping)

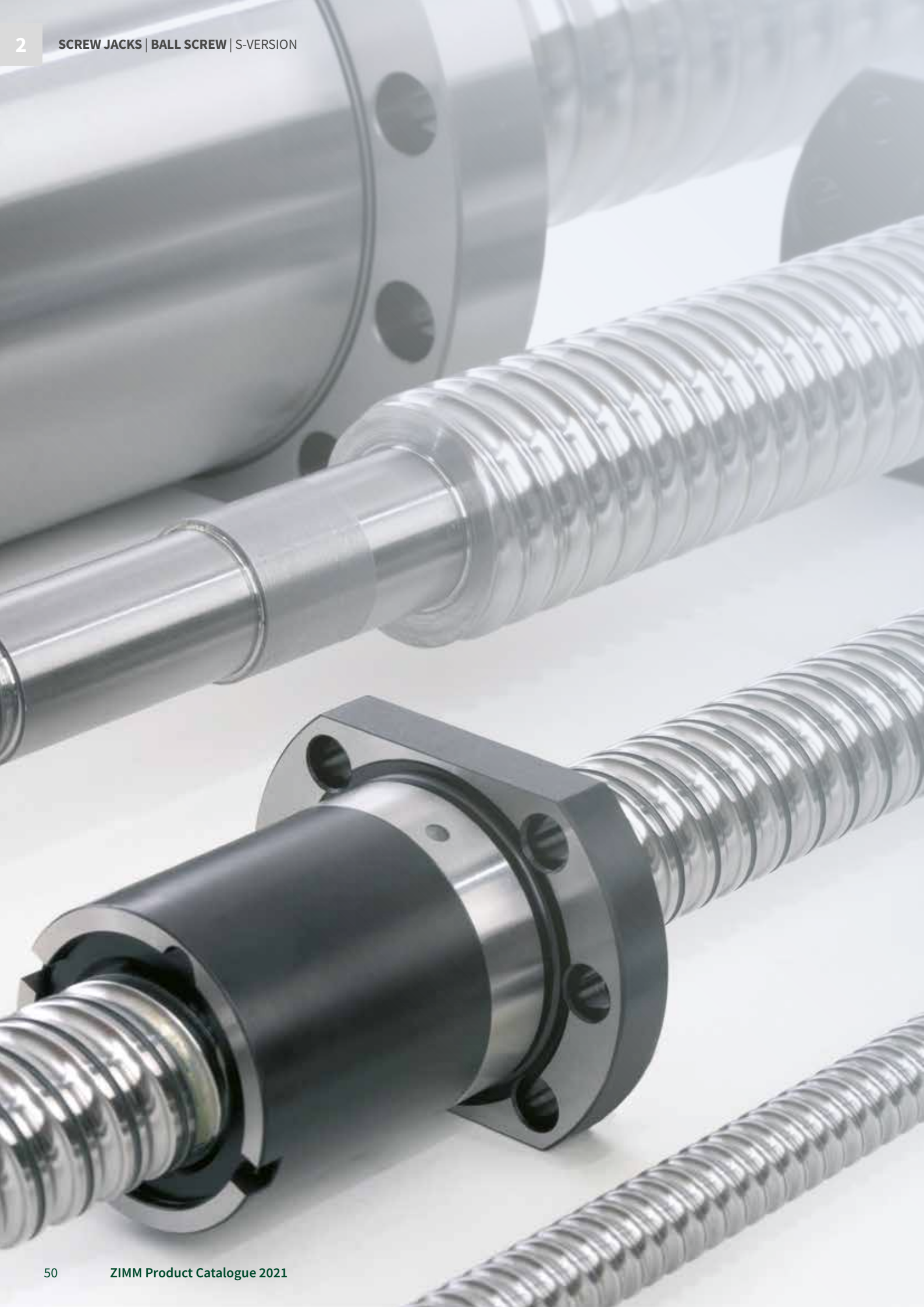

# GUIDE TO TRAPEZOIDAL THREAD OR BALL SCREW

Discover the appropriate spindle for your application



## Which spindle type should you use?

The parameters and requirements for the application of your lifting gear are crucial when choosing either a trapezoidal thread or ball screw, especially concerning the following:

- Duty cycle
- Repetition accuracy and positioning accuracy
- Stroke speed
- stat. / dyn. loading  
(Hold load in position or move)
- Service life and maintenance

### Features of TR (Tr)

The trapezoidal thread is robust and moderately priced. It is the right choice for most adjustment tasks.

Spindle and nut are exposed to friction and must be well lubricated. Usually it is suitable for applications up to max. 20% of duty cycle. Most single-start trapezoidal threads are self-locking (that means the load is held at engine stop, which is particularly useful in suspended loads or applications where loads are being lifted). Trapezoidal threaded spindles are also available in stainless material on request. ZIMM offers a wide selection of different nuts which have different advantages. Another aspect is the safety nut systems (SIFA) which are only available in trapezoidal thread design. There is no calculation for the life span of the trapezoidal thread drives as there is for the ball screw drives.



### Features of ball screw (KGT)

The ball screw is used primarily when higher positioning and repetition movements are the priority.

The efficient ball screw principle of the threaded nut allows higher operation cycles, higher duty cycle and speeds. This is due to the higher efficiency compared to the trapezoidal thread, i.e. a lower energy consumption as well as lower heat generation due to the smoother movements. The operation cycle can be up to 4x higher than with the trapezoidal thread.

The ball screws are offered in different pitch, which result in different lifting speeds. Important note: Ball screws are not self-locking, therefore a holding brake is necessary.



## Notes on KGT

### Service life

Tell us the load and stroke speed and we will calculate the service life.

### Contamination

All nuts are fitted with scrapers. For heavy contamination and fine dust/chips, we recommend fitting bellows or a spiral spring cover.

### Escape/rotation protection

Under no circumstances may the nut be screwed off the screw. We therefore always provide escape/rotation protection on the S version.

### Grease nipples

The standard position of the grease nipple on the S version is on the gearbox face "C". Optionally, face A is available. Faces B and D are available on request.

### Pitch accuracy

The pitch accuracy is 0,05/300 mm. Induction hardened and polished.

### No self-locking

Due to the low-rolling friction, ball screws are not self-locking. A holding brake is necessary: a motor brake or a spring pressure brake is required.

### Start ramp / braking ramp

We recommend using a frequency converter or a servomotor, especially for high lead screw jacks. This allows regulation of the start ramp / braking ramp. This ensures protection for the entire system. Safety clearance (L3, see dimension drawings) can also be reduced at your own discretion, in particular for high pitches.

**KGT** **S** **5 to 25 kN**  
**KGT-S** | translating screw

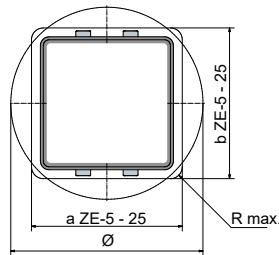
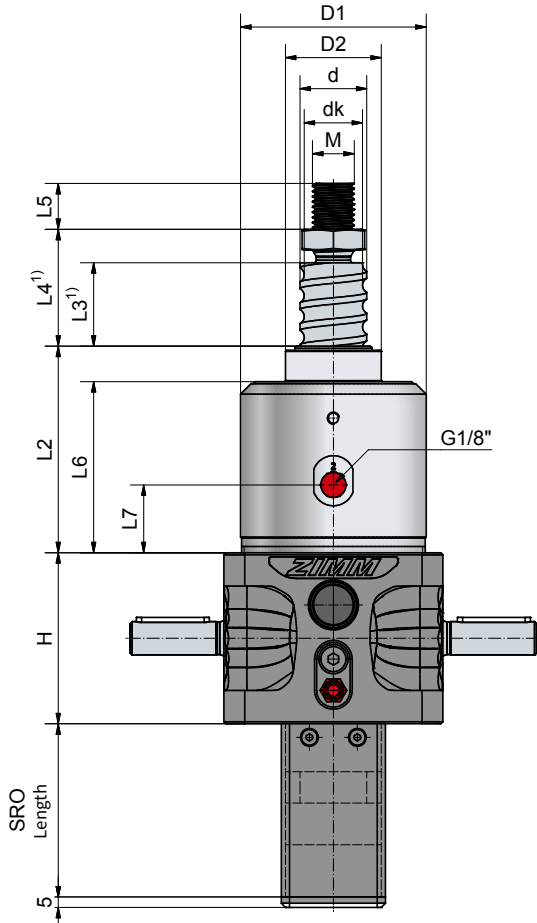

**Opening for protective tube SRO**

ZE-5	ZE-10	ZE-25
a41 x b45, or Ø50	a60 x b60, R max. 8 or Ø70	

VS Rotation protection is recommended as standard.

**Protective tube length SRO**

Without escape/rotation protection	$(L4 = 203 \text{ to } 224 \times 2) + \text{stroke}$
Escape/rotation protection	$VS = (L4 \times 2) + (15 \text{ to } 20) + \text{stroke}$
with rotation protection VS and limit switch set ESSET	$ES = VS + (43 \text{ to } 45) + \text{stroke}$
with rotation protection VS and ESSET and KAR	$ES + (59 \text{ to } 64 \text{    } 49 \text{ to } 59) + \text{stroke}$

Detailed calculation of the fitting dimensions (bellows, screw, protective tube...) can be conveniently determined with our online configurator: [www.zimm.com](http://www.zimm.com)

Screw jacks	KGT Screw ØxP	Stroke per drive revolution		KGT Load rating kN		Axial play max <sup>3)</sup> mm
		SN	SL	dyn. C <sup>2)</sup>	stat. Co=Coa	
ZE-5	16x5	1,25	0,31	10,1	12	0,06
	16x10	2,50	0,63	11,1	12,9	0,06
	25x5	1,25	0,31	13,7	21,5	0,06
ZE-10	25x10	2,50	0,63	25,2	45,4	0,06
	25x25	6,25	1,56	20,7	37,3	0,06
	25x50	12,50	3,14	19,2	37,3	0,06
ZE-25	32x5	0,83	0,21	24,8	49,7	0,06
	32x10	1,67	0,42	30,8	45,6	0,06
	32x20	3,33	0,83	32,9	47,1	0,06
	32x40	6,67	1,67	18,3	37,3	0,06

# Technical data

## ZE-5-S

max. compressive/tensile force, static:	5 kN (0,5 t)
Input speed:	1500 rpm / max. 3000 rpm
Gearbox operating temperature:	max. 60°C, higher on request
Moment of inertia:	N: 0,17 kg cm <sup>2</sup> / L: 0,093 kg cm <sup>2</sup>
Input torque (at 1500 rpm):	max. 4,7 Nm (N) / max. 1,5 Nm (L)
Drive-through torque:	max. 39 Nm
Gear ratio:	4:1 (Normal) / 16:1 (Low)
Housing material:	aluminium, corrosion-resistant
Worm shaft:	steel, case-hardened, ground
Weight of screw jack body:	1,5 kg
Gearbox / Screw lubrication:	synthetic gear oil / grease lubrication

## ZE-25-S

max. compressive/tensile force, static:	25 kN (2,5 t)
Input speed:	1500 rpm / max. 3000 rpm
Gearbox operating temperature:	max. 60°C, higher on request
Moment of inertia:	N: 0,957 kg cm <sup>2</sup> / L: 0,461 kg cm <sup>2</sup>
Input torque (at 1500 rpm):	max. 18 Nm (N) / max. 10 Nm (L)
Drive-through torque:	max. 108 Nm
Gear ratio:	6:1 (Normal) / 24:1 (Low)
Housing material:	aluminium, corrosion-resistant
Worm shaft:	steel, case-hardened, ground
Weight of screw jack body:	5,2 kg
Gearbox / Screw lubrication:	synthetic gear oil / grease lubrication

## ZE-10-S

max. compressive/tensile force, static:	10 kN (1 t)
Input speed:	1500 rpm / max. 3000 rpm
Gearbox operating temperature:	max. 60°C, higher on request
Moment of inertia:	N: 0,478 kg cm <sup>2</sup> / L: 0,233 kg cm <sup>2</sup>
Input torque (at 1500 rpm):	max. 13,5 Nm (N) / max. 7,5 Nm (L)
Drive-through torque:	max. 57 Nm
Gear ratio:	4:1 (Normal) / 16:1 (Low)
Housing material:	aluminium, corrosion-resistant
Worm shaft:	steel, case-hardened, ground
Weight of screw jack body:	2,8 kg
Gearbox / Screw lubrication:	synthetic gear oil / grease lubrication

### Ordering example: ZE-25-SN-KGT 32x10, C = 30,8

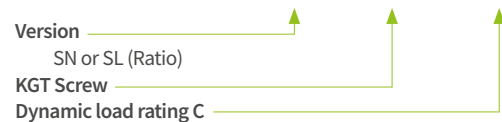

Because of the lack of friction, a holding brake is necessary: a motor brake or a spring pressure brake is required.

**Screw:** 1.1213 (Cf53), induction hardened and polished.

Screw jacks	KGT Screw ØxP	Dimensions mm											
		H	d	dk	D1	D2	L2	L3 <sup>1)</sup>	L4 <sup>1)</sup>	L5	L6	L7	M
ZE-5	16x5	62	15,5	12,9	59	29	66	15	25	19	54	23	M12
	16x10	62	15,5	12,9	59	29	66	25	35	19	54	23	M12
ZE-10	25x5	74	24,5	21,9	69	39	85	15	27	20	69	21	M14
	25x10	74	24,5	21,9	69	39	85	25	37	20	69	21	M14
	25x25	74	24,5	21,9	69	39	85	60	72	20	69	21	M14
	25x50	74	24,5	21,9	69	39	85	125	137	20	69	21	M14
ZE-25	32x5	82	31,5	28,9	89	46	99	15	31	22	82	33	M20
	32x10	82	31,5	26,8	89	46	99	20	36	22	82	33	M20
	32x20	82	31,5	26,8	89	46	99	35	51	22	82	33	M20
	32x40	82	31,5	28,9	89	46	99	70	86	22	82	33	M20

1) Depending on the control system and drive, the dimension L3 can be reduced at your own discretion. An extension may be required if a bellows or spiral spring is fitted

2) Dynamic load rating to DIN ISO 3408

3) Reduced play 0,02 mm available on request

**KGT** **S** **50 to 200 kN**  
**KGT-S** | translating screw

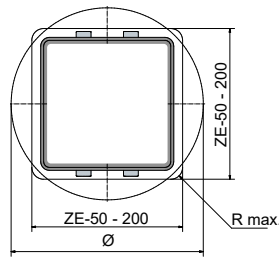
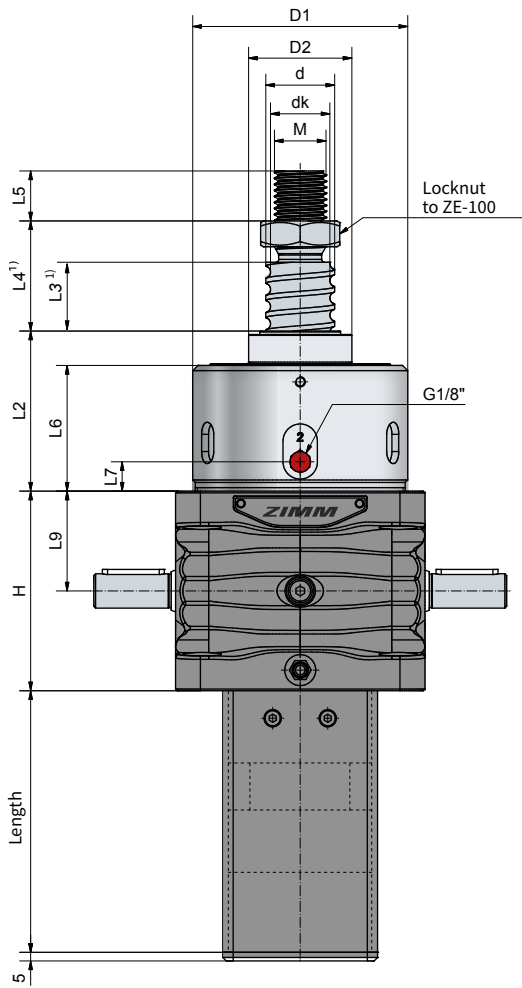

**Opening for protective tube SRO**

ZE-50	ZE-100	ZE-150	ZE-200
102x102, R max. 10 or Ø130		135x135, R max. 15 or Ø175	

VS Rotation protection is recommended as standard.

**Protective tube length SRO** (Example ZE-50)

<b>Without escape/rotation protection</b>	KGT-Basic length (L4 x 2, 4 variations each) + stroke
<b>Escape/rotation protection</b>	KGT-Basic length + AS/VS (30) + stroke
<b>Rotation protection, with limit switch set ESSET</b>	KGT-Basic length + AS/VS + ES (55) + stroke
<b>with rotation protection and ESSET and KAR</b>	KGT-Basic length + AS/VS + ES + KAR (4 variations each) + stroke

Detailed calculation of the fitting dimensions (bellows, screw, protective tube...) can be conveniently determined with our online configurator: [www.zimm.com](http://www.zimm.com)

Screw jacks	KGT Screw ØxP	Stroke per drive revolution		KGT Load rating kN		Axial play max <sup>4)</sup> mm
		SN	SL	dyn. C <sup>2)</sup>	stat. Co=Coa	
ZE-50	40x5	0,71	0,18	27,5	63,6	0,06
	40x10	1,43	0,36	46,1	71,3	0,06
	40x20	2,86	0,72	44	80,4	0,06
	40x40	5,71	1,43	35	101,9	0,06
ZE-100	50x10	1,11	0,28	122,4	248,6	0,06
	50x20	2,22	0,56	127,3	270,3	0,06
	50x40	4,44	1,11	84,7	143,1	0,06
ZE-150	63x10	1,11	0,28	150,2	598,4	0,03
	63x20	2,22	0,56	173,5	346,2	0,03
	63x40	4,44	1,11	96,6	205,1	0,03
	63x60 <sup>3)</sup>	6,67	1,67	59,5	102,5	0,03
ZE-200	80x10 <sup>3)</sup>	1,25	0,42	206	710,8	0,03
	80x20	2,50	0,83	463,5	1163,7	0,03
	80x40	5,00	1,67	283,8	902	0,03
	80x60	7,50	2,50	193,6	582,5	0,03

# Technical data

## ZE-50-S

max. compressive/tensile force, static:	50 kN (5 t)
Input speed:	1500 rpm / max. 1800 rpm
Gearbox operating temperature:	max. 60°C, higher on request
Moment of inertia:	N: 2,85 kg cm <sup>2</sup> / L: 1,75 kg cm <sup>2</sup>
Input torque (at 1500 rpm):	max. 31,5 Nm (N) / max. 10,4 Nm (L)
Drive-through torque:	max. 260 Nm
Gear ratio:	7:1 (Normal) / 28:1 (Low)
Housing material:	GGG, corrosion-resistant
Worm shaft:	steel, case-hardened, ground
Weight of screw jack body:	23 kg

## ZE-150-S

max. compressive/tensile force, static:	150 kN (15 t)
Input speed:	1500 rpm / max. 1800 rpm
Gearbox operating temperature:	max. 60°C, higher on request
Moment of inertia:	N: 7,92 kg cm <sup>2</sup> / L: 5,17 kg cm <sup>2</sup>
Input torque (at 1500 rpm):	max. 75,1 Nm (N) / max. 20,7 Nm (L)
Drive-through torque:	max. 540 Nm
Gear ratio:	9:1 (Normal) / 36:1 (Low)
Housing material:	GGG, corrosion-resistant
Worm shaft:	steel, case-hardened, ground
Weight of screw jack body:	42 kg

## ZE-100-S

max. compressive/tensile force, static:	100 kN (10 t)
Input speed:	1500 rpm / max. 1800 rpm
Gearbox operating temperature:	max. 60°C, higher on request
Moment of inertia:	N: 5,45 kg cm <sup>2</sup> / L: 3,43 kg cm <sup>2</sup>
Input torque (at 1500 rpm):	max. 53,4 Nm (N) / max. 13,5 Nm (L)
Drive-through torque:	max. 540 Nm
Gear ratio:	9:1 (Normal) / 36:1 (Low)
Housing material:	GGG, corrosion-resistant
Worm shaft:	steel, case-hardened, ground
Weight of screw jack body:	39 kg

## ZE-200-S

max. compressive/tensile force, static:	200 kN (20 t)
Input speed:	1500 rpm / max. 1800 rpm
Gearbox operating temperature:	max. 60°C, higher on request
Moment of inertia:	N: 16,91 kg cm <sup>2</sup> / L: 8,59 kg cm <sup>2</sup>
Input torque (at 1500 rpm):	max. 155 Nm (N) / max. 61 Nm (L)
Drive-through torque:	max. 700 Nm
Gear ratio:	8:1 (Normal) / 24:1 (Low)
Housing material:	GGG, corrosion-resistant
Worm shaft:	steel, case-hardened, ground
Weight of screw jack body:	82 kg

Because of the lack of friction, a holding brake is necessary: a motor brake or a spring pressure brake is required.

**Material:** 1.1213 (Cf53), induction hardened and polished.

### Note for the high-performance gearbox series ZE-H

For high duty factor or input drive speed up to 3000 rpm, please contact our sales department.

### Ordering example: ZE-50-SL-KGT 40x20, C = 44 kN

Version \_\_\_\_\_ ↑  
 SN or SL (Ratio) \_\_\_\_\_ ↑  
 KGT Screw \_\_\_\_\_ ↑  
 Dynamic load rating C \_\_\_\_\_ ↑

Screw jacks	KGT Screw ØxP	Dimensions mm												
		H	d	dk	D1	D2	L2	L3 <sup>1)</sup>	L4 <sup>1)</sup>	L5	L6	L7	L9	M
ZE-50	40x5	116	39	36,4	125	60	93	15	39	29	74	17	58	M30
	40x10	116	39	33,3	125	60	93	15	39	29	74	17	58	M30
	40x20	116	39	34,3	125	60	93	30	54	29	74	17	58	M30
	40x40	116	39	36,4	125	60	93	60	84	29	74	17	58	M30
ZE-100	50x10	160	49	43,3	148	85	148	20	48	48	118	19	80	M36
	50x20	160	49	43,3	148	85	148	40	68	48	118	19	80	M36
	50x40	160	50	41,1	148	85	148	80	108	48	118	19	80	M36
ZE-150	63x10	185	63	56,6	168	90	150	20	48	48	118	24	92,5	M42x2
	63x20	185	63	51,8	168	90	150	40	48	48	118	24	92,5	M42x2
	63x40	185	63	54,1	168	90	150	80	80	48	118	24	92,5	M42x2
	63x60 <sup>3)</sup>	185	63	54,1	168	90	150	120	120	48	118	24	92,5	M42x2
ZE-200	80x10 <sup>3)</sup>	176	79,4	74,36	214	110	226	20	48	58	192	128	88	M56x2
	80x20	176	79,4	69,32	214	110	226	40	48	58	192	128	88	M56x2
	80x40	176	79,4	72,68	214	110	226	80	80	58	192	128	88	M56x2
	80x60	176	79,4	72,68	214	110	226	120	120	58	192	128	88	M56x2

1) Depending on the control system and drive, the dimension L3 can be reduced at your own discretion. An extension may be required if a bellows or spiral spring is fitted

2) Dynamic load rating to DIN ISO 3408

3) Non-preferred design

4) Reduced play 0,02 mm available on request

**KGT** **S** **250 to 350 kN**  
**KGT-S** | translating screw

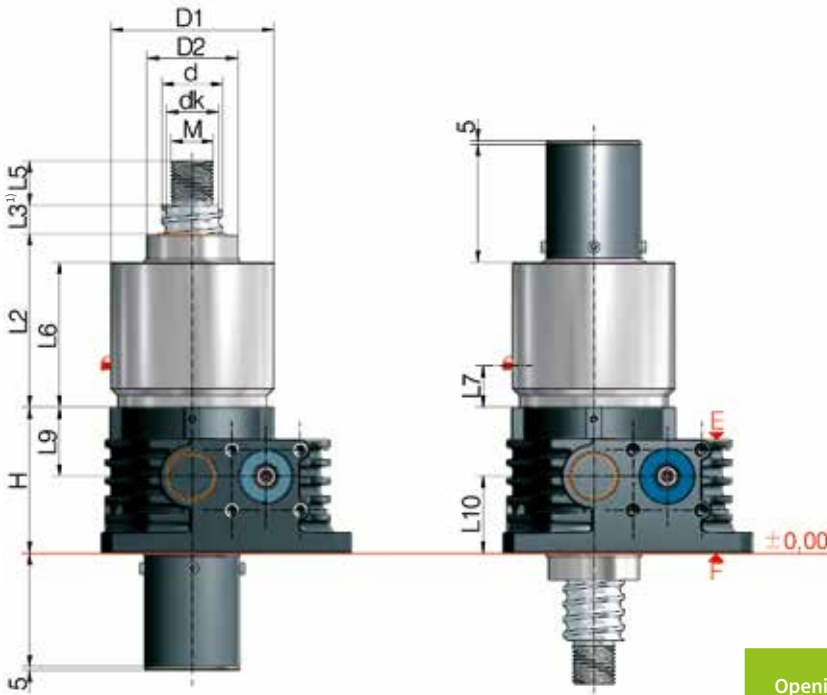

**Opening for protective tube SRO**



**Square:**  
 Optionally available with limit switch ES.



**Round:**  
 Optionally available with escape protection AS.

	Z-250	Z-350
Opening protective tube	<b>Square:</b> 138x138, R max. 25 or Ø172	<b>Square:</b> 180x180, R max. 30 or Ø228
	<b>Round:</b> Ø142	<b>Round:</b> Ø168
Dimension protective tube	<b>Square:</b> □ 120 x 120	<b>Square:</b> □ 160 x 160
	<b>Round:</b> Ø125	<b>Round:</b> Ø150

*For square version VS rotation protection included as standard.*

*Round version optionally also with AS escape protection.*

Detailed calculation of the fitting dimensions (bellows, screw, protective tube...) can be conveniently determined with our online configurator: [www.zimm.com](http://www.zimm.com)

Screw jacks	KGT Screw ØxP	Stroke per drive revolution		KGT Load rating kN		Dimensions mm					Axial play max mm
		SN	SL	dyn. C <sup>2)</sup>	stat. C <sub>0</sub> =C <sub>0a</sub>	H	d	dk	D1	D2	
Z-250	80x10 <sup>4)</sup>	0,94	0,31	193	993,4	193	80	73,6	216	120	0,03
	80x20	1,87	0,63	359,2	942,5	193	80	67	216	120	0,03
	80x40	3,75	1,25	251,2	565,5	193	80	67	216	120	0,03
	80x60	5,62	1,88	189,1	377	193	80	67	216	120	0,03
Z-350	100x20	1,87	0,63	330,2	979,1	230	100	87,4	275	145	0,03
	100x40	3,75	1,25	270	734	230	100	87,4	275	145	0,03
	100x60	5,62	1,88	203	489,6	230	100	87,4	275	145	0,03
	100x80 <sup>4)</sup>	7,50	2,50	203	489,6	230	100	87,4	275	145	0,03

Screw jacks	KGT Screw ØxP	Stroke per drive revolution		KGT Load rating kN		Dimensions mm							
		SN	SL	dyn. C <sup>2)</sup>	stat. C <sub>0</sub> =C <sub>0a</sub>	L2	L3 <sup>1)</sup>	L5	L6	L7	L9	L10	M
Z-250	80x10 <sup>4)</sup>	0,94	0,31	193	993,4	228 <sup>5)</sup>	20	58	191 <sup>5)</sup>	45	91	102	M56x2
	80x20	1,87	0,63	359,2	942,5	228 <sup>5)</sup>	40	58	191 <sup>5)</sup>	45	91	102	M56x2
	80x40	3,75	1,25	251,2	565,5	228 <sup>5)</sup>	80	58	191 <sup>5)</sup>	45	91	102	M56x2
	80x60	5,62	1,88	189,1	377	228 <sup>5)</sup>	120	58	191 <sup>5)</sup>	45	91	102	M56x2
Z-350	100x20	1,87	0,63	330,2	979,1	223	40	78	199	54	115	115	M72x3
	100x40	3,75	1,25	270	734	223	80	78	199	54	115	115	M72x3
	100x60	5,62	1,88	203	489,6	223	120	78	199	54	115	115	M72x3
	100x80 <sup>4)</sup>	7,50	2,50	203	489,6	263	160	78	239	54	115	115	M72x3

1) Depending on the control system and drive, the dimension L3 can be reduced at your own discretion. An extension may be required if a bellows or spiral spring is fitted

2) Dynamic load rating to DIN ISO 3408

4) Non-preferred design

5) Screw Face F: L2 = 244, L6 = 202



# Technical data

## Z-250-S

max. compressive/tensile force, static:	1500 rpm / max. 1800 rpm
Input speed:	max. 60°C, higher on request
Gearbox operating temperature:	N: 53,8 kg cm <sup>2</sup> / L: 22,0 kg cm <sup>2</sup>
Moment of inertia:	max. 152 Nm (N) / max. 41,4 Nm (L)
Input torque (at 1500 rpm):	max. 770 Nm
Drive-through torque:	10,66:1 (Normal) / 32:1 (Low)
Gear ratio:	GGG-50, corrosion-resistant
Housing material:	steel, case-hardened, ground
Worm shaft:	59 kg
Weight of screw jack body:	

250 kN (25 t)

### Note for holding brake

Because of the lack of friction, a holding brake is necessary: a motor brake or a spring pressure brake is required.

Detailed calculation of the fitting dimensions (bellows, screw, protective tube...) can be conveniently determined with our online configurator: [www.zimm.com](http://www.zimm.com)

## Z-350-S

max. compressive/tensile force, static:	1000 rpm / max. 1200 rpm
Input speed:	max. 60°C, higher on request
Gearbox operating temperature:	N: 148,9 kg cm <sup>2</sup> / L: 66,1 kg cm <sup>2</sup>
Moment of inertia:	max. 265 Nm (N) / max. 100 Nm (L)
Input torque (at 1500 rpm):	max. 1800 Nm
Drive-through torque:	10,66:1 (Normal) / 32:1 (Low)
Gear ratio:	GGG-50, corrosion-resistant
Housing material:	steel, case-hardened, ground
Worm shaft:	112 kg
Weight of screw jack body:	

350 kN (35 t)

Ordering example: **Z-250-SN-E-KGT 80x40, C = 251,2 kN**

Screw Face E or F

Dynamic load rating C



**KGT** **S** **500 to 1000 kN**  
**KGT-S** | translating screw

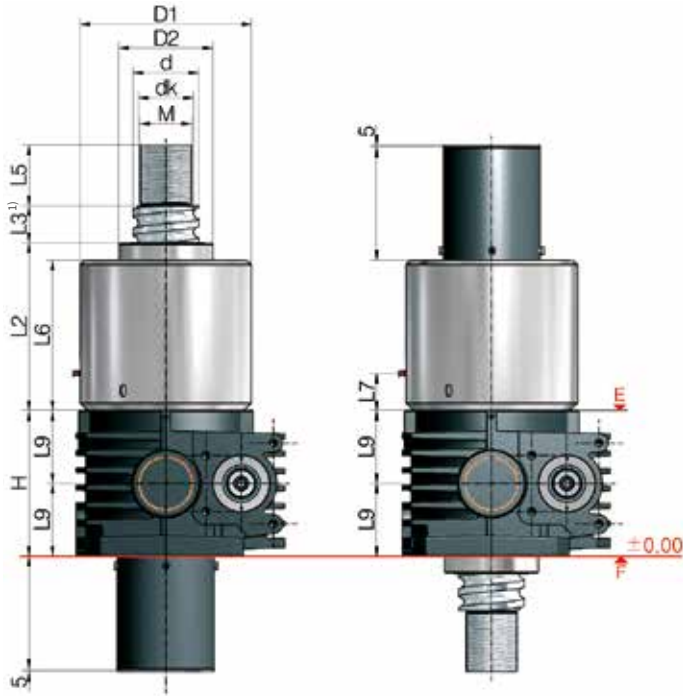

**Opening for protective tube SRO**

**Square:** Optionally available with limit switch ES.  
**Round:** Optionally available with escape protection AS.

	Z-500	Z-750	Z-1000
<b>Opening protective tube</b>	<b>Square:</b> 202x202, R max. 32 or Ø256 <b>Round:</b> Ø200	<b>Square:</b> 222x222, R max. 32 or Ø285 <b>Round:</b> Ø320	<b>Square:</b> 245x245, R max. 35 or Ø315 <b>Round:</b> Ø280
<b>Dimension protective tube</b>	<b>Square:</b> □ 180 x 180 <b>Round:</b> Ø180	<b>Square:</b> □ 200 x 200 <b>Round:</b> Ø210	<b>Square:</b> □ 200 x 200 <b>Round:</b> Ø260

*For square version VS rotation protection included as standard. Round version optionally also with AS escape protection.*

Screw jacks	KGT Screw ØxP	Stroke per drive revolution		KGT Load rating kN		Dimensions mm					Axial play max mm
		SN	SL	dyn. C <sup>2)</sup>	stat. C <sub>0</sub> =C <sub>0a</sub>	H	d	dk	D1	D2	
Z-500	125x25	2,34	0,78	575,1	1863	260	125	107,8	315	170	0,03
	125x40	3,75	1,25	402,2	1117	260	125	107,8	315	170	0,03
	125x60	5,62	1,88	302,8	745,3	260	125	107,8	315	170	0,03
	125x80	7,50	2,50	218,7	630,5	260	125	112,4	315	170	0,03
Z-750	140x25	1,88	0,63	774,3	3082	310	140	122,8	365	200	0,03
	140x40	3,00	1,00	754,0	2100	310	140	117	365	200	0,03
	140x60	4,50	1,50	616,7	1575	310	140	117	365	200	0,03
	140x80	6,00	2,00	464,3	1048	310	140	117	365	200	0,03
Z-1000	160x25	1,88	0,63	884,7	4068	340	160	142,8	405	250	0,03
	160x40	3,00	1,00	1069,9	3016	340	160	132,8	405	250	0,03
	160x60	4,50	1,50	663,0	1923	340	160	137	405	250	0,03
	160x80	6,00	2,00	499,1	1282	340	160	137	405	250	0,03

Screw jacks	KGT Screw ØxP	Stroke per drive revolution		KGT Load rating kN		Dimensions mm							
		SN	SL	dyn. C <sup>2)</sup>	stat. C <sub>0</sub> =C <sub>0a</sub>	L2	L3 <sup>1)</sup>	L5	L6	L7	L9	L10	M
Z-500	125x25	2,34	0,78	575,1	1863	283	50	118	251	55	130	L9	M100x3
	125x40	3,75	1,25	402,2	1117	283	80	118	251	55	130	L9	M100x3
	125x60	5,62	1,88	302,8	745,3	283	120	118	251	55	130	L9	M100x3
	125x80	7,50	2,50	218,7	630,5	283	160	118	251	55	130	L9	M100x3
Z-750	140x25	1,88	0,63	774,3	3082	374	50	130	337	84	155	L9	M110x3
	140x40	3,00	1,00	754,0	2100	374	80	130	337	84	155	L9	M110x3
	140x60	4,50	1,50	616,7	1575	374	120	130	337	84	155	L9	M110x3
	140x80	6,00	2,00	464,3	1048	374	160	130	337	84	155	L9	M110x3
Z-1000	160x25	1,88	0,63	884,7	4068	392	50	130	360	79	170	L9	M110x3
	160x40	3,00	1,00	1069,9	3016	392	80	130	360	79	170	L9	M110x3
	160x60	4,50	1,50	663,0	1923	392	120	130	360	79	170	L9	M110x3
	160x80	6,00	2,00	499,1	1282	392	160	130	360	79	170	L9	M110x3

1) Depending on the control system and drive, the dimension L3 can be reduced at your own discretion. An extension may be required if a bellows or spiral spring is fitted

2) Dynamic load rating to DIN ISO 3408

# Technical data

## Z-500-S

max. compressive/tensile force, static:	500 kN (50 t)
Input speed:	1000 rpm / max. 1000 rpm
Moment of inertia:	N: 310,2 kg cm <sup>2</sup> / L: 127,8 kg cm <sup>2</sup>
Input torque (at 1000 rpm):	max. 408 Nm (N) / max. 170 Nm (L)
Drive-through torque:	max. 1940 Nm
Gear ratio:	10,66:1 (Normal) / 32:1 (Low)
Housing material:	GGG, corrosion-resistant
Weight of screw jack body:	168 kg

## Z-750-S

max. compressive/tensile force, static:	750 kN (75 t)
Input speed:	1000 rpm / max. 1000 rpm
Moment of inertia:	N: 518,1 kg cm <sup>2</sup> / L: 256,1 kg cm <sup>2</sup>
Input torque (at 1000 rpm):	max. 480 Nm (N) / max. 210 Nm (L)
Drive-through torque:	max. 4570 Nm
Gear ratio:	13,33:1 (Normal) / 40:1 (Low)
Housing material:	GGG, corrosion-resistant
Weight of screw jack body:	262 kg

## Z-1000-S

max. compressive/tensile force, static:	1000 kN (100 t)
Input speed:	1000 rpm / max. 1000 rpm
Moment of inertia:	N: 1058,2 kg cm <sup>2</sup> / L: 459,2 kg cm <sup>2</sup>
Input torque (at 1000 rpm):	max. 680 Nm (N) / max. 450 Nm (L)
Drive-through torque:	max. 4570 Nm
Gear ratio:	13,33:1 (Normal) / 40:1 (Low)
Housing material:	GGG, corrosion-resistant
Weight of screw jack body:	408 kg

Detailed calculation of the fitting dimensions (bellows, screw, protective tube...) can be conveniently determined with our online configurator: [www.zimm.com](http://www.zimm.com)

### Note for holding brake

Because of the lack of friction, a holding brake is necessary: a motor brake or a spring pressure brake is required.

### Ordering example: Z-1000-SN-E-KGT 160x40, C = 1069,9 kN

Screw Face E or F

Dynamic load rating C



KGT R 5 to 25 kN  
KGT-R | rotating screw

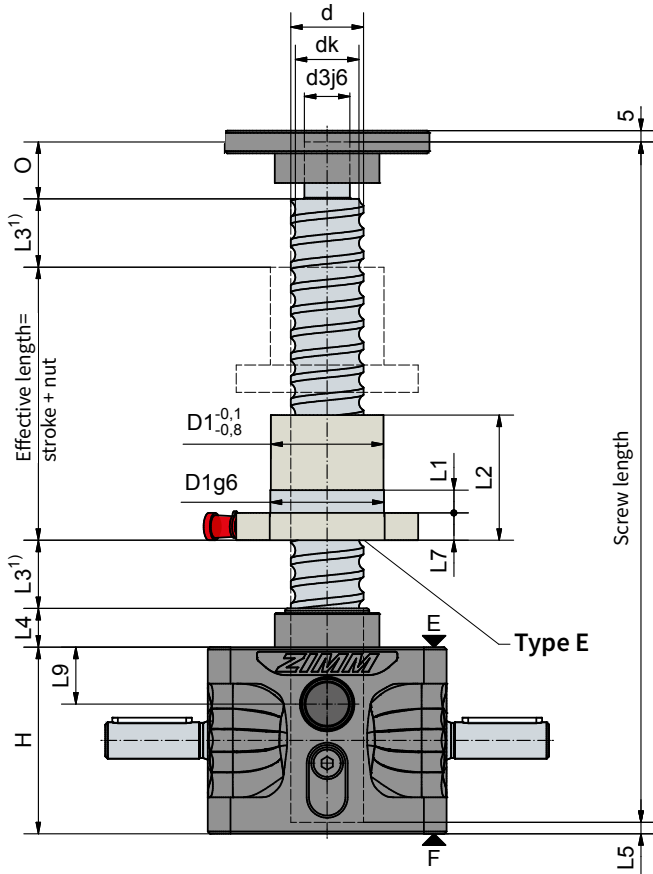

**Position of the flanged nut:**  
G = flange gearbox side (as shown)  
S = flange screw side

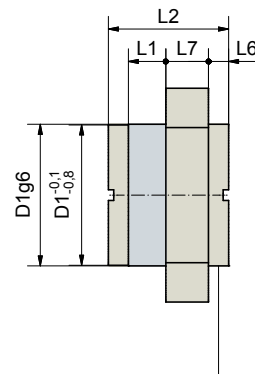

Type S

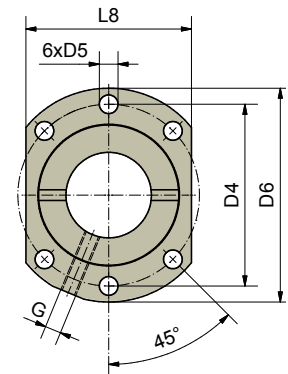

Hole pattern 1 to DIN 69051

Screw jacks	KGT Screw ØxP	Stroke per drive revolution		KGT Load rating kN		Nur Type	Hole pattern	Lubrication hole G	Axial play max <sup>9)</sup> mm
		RN	RL	dyn. C <sup>2)</sup>	stat. C <sub>0</sub> =C <sub>0a</sub>				
ZE-5	16x5	1,25	0,31	10,1	12	E	1	M6	0,06
	16x10	2,50	0,63	11,1	12,9	E	1	M6	0,06
ZE-10	25x5	1,25	0,31	13,7	21,5	E	1	M6	0,06
	25x10	2,50	0,63	25,2	45,4	E	1	M6	0,06
	25x25	6,25	1,56	20,7	37,3	S	1	M6	0,06
ZE-25	25x50	12,50	3,14	19,2	37,3	S	1	M6	0,06
	32x5	0,83	0,21	24,8	49,7	E	1	M6	0,06
	32x10	1,67	0,42	30,8	45,6	E	1	M8x1	0,06
	32x20	3,33	0,83	32,9	47,1	E	1	M6	0,06
	32x40 <sup>3)</sup>	6,67	1,67	18,3	37,3	S	N <sup>4)</sup>	M6	0,06

# Technical data

## ZE-5-R

max. compressive/tensile force, static:	5 kN (0,5 t)
Input speed:	1500 rpm / max. 3000 rpm
Gearbox operating temperature:	max. 60°C, higher on request
Moment of inertia:	N: 0,132 kg cm <sup>2</sup> / L: 0,091 kg cm <sup>2</sup>
Input torque (at 1500 rpm):	max. 4,7 Nm (N) / max. 1,5 Nm (L)
Drive-through torque:	max. 39 Nm
Gear ratio:	4:1 (Normal) / 16:1 (Low)
Housing material:	aluminium, corrosion-resistant
Worm shaft:	steel, case-hardened, ground
Weight of screw jack body	1,2 kg
Gearbox / Screw lubrication:	synthetic gear oil / grease lubrication

## ZE-25-R

max. compressive/tensile force, static:	25 kN (2,5 t)
Input speed:	1500 rpm / max. 3000 rpm
Gearbox operating temperature:	max. 60°C, higher on request
Moment of inertia:	N: 0,667 kg cm <sup>2</sup> / L: 0,443 kg cm <sup>2</sup>
Input torque (at 1500 rpm):	max. 18 Nm (N) / max. 10 Nm (L)
Drive-through torque:	max. 108 Nm
Gear ratio:	6:1 (Normal) / 24:1 (Low)
Housing material:	aluminium, corrosion-resistant
Worm shaft:	steel, case-hardened, ground
Weight of screw jack body	3,8 kg
Gearbox / Screw lubrication:	synthetic gear oil / grease lubrication

## ZE-10-R

max. compressive/tensile force, static:	10 kN (1 t)
Input speed:	1500 rpm / max. 3000 rpm
Gearbox operating temperature:	max. 60°C, higher on request
Moment of inertia:	N: 0,361 kg cm <sup>2</sup> / L: 0,226 kg cm <sup>2</sup>
Input torque (at 1500 rpm):	max. 13,5 Nm (N) / max. 7,5 Nm (L)
Drive-through torque:	max. 57 Nm
Gear ratio:	4:1 (Normal) / 16:1 (Low)
Housing material:	aluminium, corrosion-resistant
Worm shaft:	steel, case-hardened, ground
Weight of screw jack body	2,1 kg
Gearbox / Screw lubrication:	synthetic gear oil / grease lubrication

### Ordering example: ZE-10-RN-KGT 25x10, C = 25,2 kN - G

Version	↑
RN or RL (Ratio)	↑
KGT Screw	↑
Dynamic load rating C	↑
Nut flange	↑
G: flange gearbox side	
S: flange screw side	

Because of the lack of friction, a holding brake is necessary: a motor brake or a spring pressure brake is required.

**Screw:** 1.1213 (Cf 53), induction hardened and polished. **Pitch accuracy:** 0,05 mm / 300 mm

Screw jacks	KGT Screw ØxP	Dimensions mm																	
		d	dk	d3j6	O	H	D1	D4	D5	D6	L1	L2	L3 <sup>1)</sup>	L4	L5	L6	L7	L8	L9
ZE-5	16x5	15,5	12,9	12	15	62	28	38	5,5	48	10	42	15	12	8		10	40	18
	16x10	15,5	12,9	12	15	62	28	38	5,5	48	10	55	25	12	8		10	40	18
ZE-10	25x5	24,5	21,9	15	20	74	40	51	6,6	62	10	42	15	16	8		10	48	21
	25x10	24,5	21,9	15	20	74	40	51	6,6	62	16	55	25	16	8		10	48	21
	25x25	24,5	21,9	15	20	74	40	51	6,6	62	9	35	60	16	8	8	10	48	21
	25x50	24,5	21,9	15	20	74	40	51	6,6	62	10	58	125	16	8	10	10	48	21
ZE-25	32x5	31,5	28,9	20	25	82	50	65	9	80	10	55	15	17	5		12	62	25
	32x10	31,5	26,8	20	25	82	53 <sup>6)</sup>	65	9	80	16	69	20	17	5		12	62	25
	32x20	31,5	26,8	20	25	82	53 <sup>6)</sup>	65	9	80	16	80	35	17	5		12	62	25
	32x40 <sup>3)</sup>	31,5	28,9	20	25	82	53 <sup>6)</sup>	68 <sup>6)</sup>	7 <sup>6)</sup>	80	14	45	70	17	5	7,5	16	<sup>3)</sup>	25

An increased screw (such as: ZE-10-RN with screw 32x10) can also be used for the rotating version

1) Depending on the control system and drive, the dimension L3 can be reduced at your own discretion. An extension may be required if a bellows or spiral spring is fitted

2) Dynamic load rating to DIN ISO 3408

3) Round flange

4) Hole pattern on request

5) Reduced play 0,02 mm available on request

6) Not to DIN 69051

7) Service life calculation with C<sub>dym</sub> 159 kN (gearbox bearing)

KGT R 35 to 100 kN  
KGT-R | rotating screw

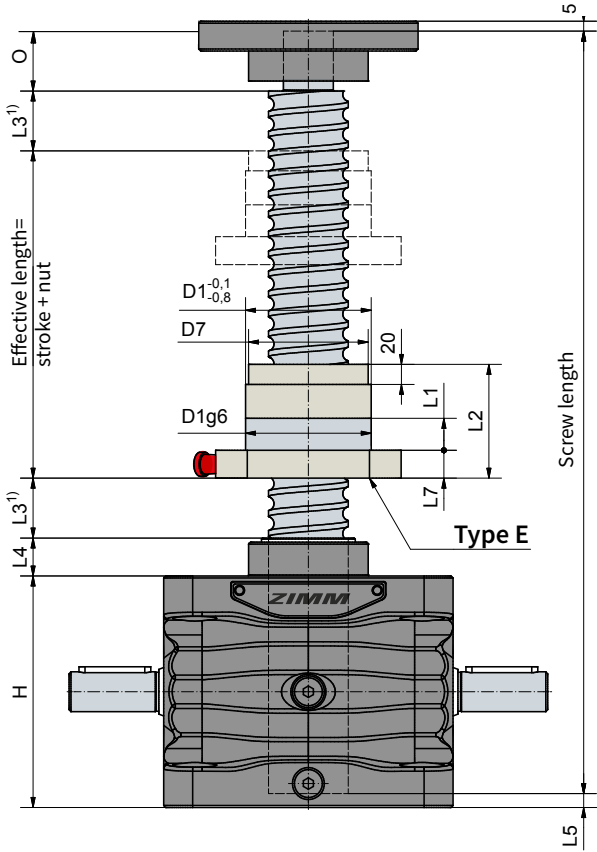

**Position of the flanged nut:**  
G = flange gearbox side (as shown)  
S = flange screw side

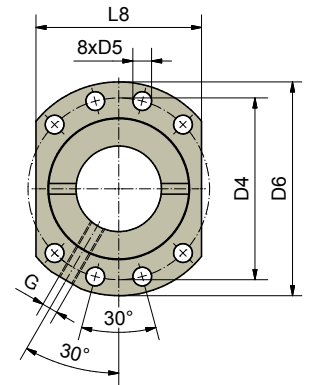
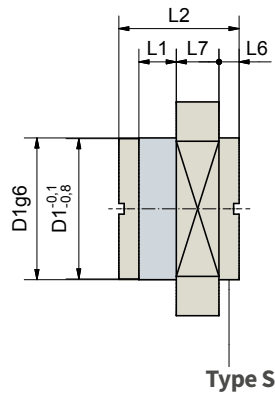

Hole pattern 2 to DIN 69051

Screw jacks	KGT Screw ØxP	Stroke per drive revolution		KGT Load rating kN		Nut Type	Nut Hole pattern	Lubrication hole G	Axial play max <sup>6)</sup> mm
		RN	RL	dyn. C <sup>2)</sup>	stat. C <sub>0</sub> =C <sub>0a</sub>				
ZE-35	40x5	0,71	0,18	27,5	63,3	E	2	M6	0,06
	40x10	1,43	0,36	46,1	71,3	E	2	M8x1	0,06
	40x20	2,86	0,72	44	80,4	E	2	M8x1	0,06
	40x40 <sup>3)</sup>	5,71	1,43	39,5	102,1	S	2	M8x1	0,06
ZE-50	40x5	0,71	0,18	27,5	63,6	E	2	M6	0,06
	40x10	1,43	0,36	46,1	71,3	E	2	M8x1	0,06
	40x20	2,86	0,72	44	80,4	E	2	M8x1	0,06
	40x40 <sup>3)</sup>	5,71	1,43	39,5	102,1	S	2	M8x1	0,06
ZE-100	50x10	1,11	0,28	122,4	248,6	E	2	M8x1	0,06
	50x20	2,22	0,56	114,9	237,6	S	N <sup>4)</sup>	M8x1	0,06
	50x40	4,44	1,11	84,7	143,1	E	2	M8x1	0,06
	50x50 <sup>5)</sup>	5,56	1,39	84,7	143,1	E	2	M8x1	0,03

# Technical data

## ZE-35-R

max. compressive/tensile force, static:	35 kN (3,5 t)
Input speed:	1500 rpm / max. 1800 rpm
Gearbox operating temperature:	max. 60°C, higher on request
Moment of inertia:	N: 0,97 kg cm <sup>2</sup> / L: 0,67 kg cm <sup>2</sup>
Input torque (at 1500 rpm):	max. 19,8 Nm (N) / max. 9 Nm (L)
Drive-through torque:	max. 130 Nm
Gear ratio:	7:1 (Normal) / 28:1 (Low)
Housing material :	GGG, corrosion-resistant
Worm shaft:	steel, case-hardened, ground
Weight of screw jack body:	9,5 kg

## ZE-100-R

max. compressive/tensile force, static:	100 kN (10 t)
Input speed:	1500 rpm / max. 1800 rpm
Gearbox operating temperature:	max. 60°C, higher on request
Moment of inertia:	N: 4,66 kg cm <sup>2</sup> / L: 3,38 kg cm <sup>2</sup>
Input torque (at 1500 rpm):	max. 53,4 Nm (N) / max. 13,5 Nm (L)
Drive-through torque:	max. 540 Nm
Gear ratio:	9:1 (Normal) / 36:1 (Low)
Housing material :	GGG, corrosion-resistant
Worm shaft:	steel, case-hardened, ground
Weight of screw jack body:	29 kg

## ZE-50-R

max. compressive/tensile force, static:	50 kN (5 t)
Input speed:	1500 rpm / max. 1800 rpm
Gearbox operating temperature:	max. 60°C, higher on request
Moment of inertia:	N: 2,49 kg cm <sup>2</sup> / L: 1,73 kg cm <sup>2</sup>
Input torque (at 1500 rpm):	max. 31,5 Nm (N) / max. 10,4 Nm (L)
Drive-through torque:	max. 260 Nm
Gear ratio:	7:1 (Normal) / 28:1 (Low)
Housing material :	GGG, corrosion-resistant
Worm shaft:	steel, case-hardened, ground
Weight of screw jack body:	17 kg

Ordering example: **ZE-35-RN-KGT 40x10, C = 46,1 kN - G**

Version	↑
RN or RL (Ratio)	↑
KGT Screw	↑
Dynamic load rating C	↑
Nut flange	↑
G: flange gearbox side	
S: flange screw side	

Because of the lack of friction, a holding brake is necessary: a motor brake or a spring pressure brake is required.

**Screw:** 1.1213 (Cf53), induction hardened and polished.

### Note for the high-performance gearbox series ZE-H

For high duty factor or input drive speed up to 3000 rpm, please contact our sales department.

Screw jacks	KGT Screw	Dimensions mm																
		ØxP	d	dk	d3j6	O	H	D1	D4	D5	D6	L1	L2	L3 <sup>1)</sup>	L4	L5	L6	L7
ZE-35	40x5	39	36,4	25	30	100	63	78	9	93	10	57	15	19	7		14	70
	40x10	39	33,3	25	30	100	63	78	9	93	16	71	15	19	7		14	70
	40x20	39	34,3	25	30	100	63	78	9	93	16	80	30	19	7		14	70
	40x40 <sup>3)</sup>	39	36,4	25	30	100	63	78	9	93	16	85	60	19	7	7,5	14	<sup>3)</sup>
ZE-50	40x5	39	36,4	25	30	116	63	78	9	93	10	57	15	19	7		14	70
	40x10	39	33,3	25	30	116	63	78	9	93	16	71	15	19	7		14	70
	40x20	39	34,3	25	30	116	63	78	9	93	16	80	30	19	7		14	70
	40x40 <sup>3)</sup>	39	36,4	25	30	116	63	78	9	93	16	85	60	19	7	7,5	14	<sup>3)</sup>
ZE-100	50x10	49	43,3	40	45	160	75	93	11	110	16	107	20	30	8		16	85
	50x20	49	43,3	40	45	160	85 <sup>7)</sup>	103 <sup>7)</sup>	11	120 <sup>7)</sup>	16	125	40	30	8		16	95
	50x40	50	41,1	40	45	160	85 <sup>7)</sup>	103 <sup>7)</sup>	11	120 <sup>7)</sup>	16	125	80	30	8		16	95
	50x50 <sup>5)</sup>	50	41,1	40	45	160	85 <sup>7)</sup>	103 <sup>7)</sup>	11	120 <sup>7)</sup>	16	145	100	30	8		16	95

An increased screw (such as: ZE-35-RN with screw 50x20) can also be used for the rotating version

1) Depending on the control system and drive, the dimension L3 can be reduced at your own discretion. An extension may be required if a bellows or spiral spring is fitted

2) Dynamic load rating to DIN ISO 3408

3) Round flange

4) Hole pattern on request

5) Non-preferred design

6) Reduced play 0,02 mm available on request

7) Not to DIN 69051

**KGT** **R** **150 to 200 kN**  
**KGT-R** | rotating screw

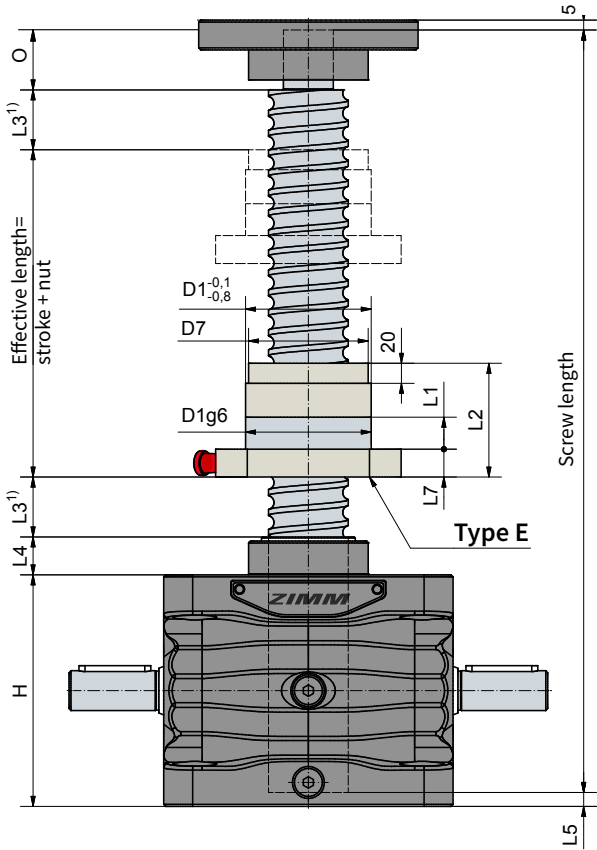

**Position of the flanged nut:**  
 G = flange gearbox side (as shown)  
 S = flange screw side

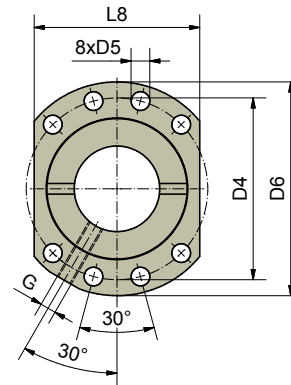

Hole pattern 2 to DIN 69051

Screw jacks	KGT Screw ØxP	Stroke per drive revolution		KGT Load rating kN		Nut		Lubrication hole G	Axial play max <sup>9)</sup> mm
		RN	RL	dyn. C <sup>2)</sup>	stat. C <sub>0</sub> =C <sub>0a</sub>	Type	Hole pattern		
ZE-150	63x10	1,11	0,28	150,2	598,4	E	2	M8x1	0,03
	63x20	2,22	0,56	173,5	346,2	E	2	M8x1	0,03
	63x40	4,44	1,11	96,6	205,1	E	2	M8x1	0,03
	63x60 <sup>3)</sup>	6,67	1,67	59,5	102,5	E	2	M8x1	0,03
ZE-200	80x10 <sup>3)</sup>	1,25	0,42	206	710,8	E	2	M8x1	0,03
	80x20	2,50	0,83	463,5	1163,7	E	2	M8x1	0,03
	80x40	5,00	1,67	283,8	902	E	2	M8x1	0,03
	80x60	7,50	2,50	193,6	582,5	E	2	M8x1	0,03



# Technical data

## ZE-150-R

max. compressive/tensile force, static:	150 kN (15 t)
Input speed:	1500 rpm / max. 1800 rpm
Gearbox operating temperature:	max. 60°C, higher on request
Moment of inertia:	N: 7,92 kg cm <sup>2</sup> / L: 5,17 kg cm <sup>2</sup>
Input torque (at 1500 rpm):	max. 75,1 Nm (N) / max. 20,7 Nm (L)
Drive-through torque:	max. 540 Nm
Gear ratio:	9:1 (Normal) / 36:1 (Low)
Housing material:	GGG, corrosion-resistant
Worm shaft:	steel, case-hardened, ground
Weight of screw jack body:	42 kg

## ZE-200-R

max. compressive/tensile force, static:	200 kN (20 t)
Input speed:	1500 rpm / max. 1800 rpm
Gearbox operating temperature:	max. 60°C, higher on request
Moment of inertia:	N: 11,5 kg cm <sup>2</sup> / L: 7,99 kg cm <sup>2</sup>
Input torque (at 1500 rpm):	max. 155 Nm (N) / max. 61 Nm (L)
Drive-through torque:	max. 700 Nm
Gear ratio:	8:1 (Normal) / 24:1 (Low)
Housing material:	GGG, corrosion-resistant
Worm shaft:	steel, case-hardened, ground
Weight of screw jack body:	50 kg

### Ordering example: ZE-150-RN-KGT 63x40, C = 96,6 kN - G

Version	_____↑
RN or RL (Ratio)	_____↑
KGT Screw	_____↑
Dynamic load rating C	_____↑
Nut flange	_____↑
G: flange gearbox side	
S: flange screw side	

Because of the lack of friction, a holding brake is necessary: a motor brake or a spring pressure brake is required.

**Screw:** 1.1213 (Cf53), induction hardened and polished.

### Note for the high-performance gearbox series ZE-H

For high duty factor or input drive speed up to 3000 rpm, please contact our sales department.

Screw jacks	KGT Screw	Dimensions mm																
		ØxP	d	dk	d3j6	O	H	D1	D4	D5	D6	D7	L1	L2	L3 <sup>1)</sup>	L4	L5	L7
ZE-150	63x10	63	56,6	45	55	185	90	108	11	125		16	135	20	32	7	18	95
	63x20	63	51,8	45	55	185	95	115	13,5	135	90	25	135	40	32	7	20	100
	63x40	63	54,1	45	55	185	95	115	13,5	135	90	25	126	80	32	7	20	100
	63x60 <sup>3)</sup>	63	54,1	45	55	185	95	115	13,5	135	90	25	126	120	32	7	20	100
ZE-200	80x10 <sup>3)</sup>	79,4	74,36	50	65	176	105	125	13,5	145	-	16	160	20	34	5	20	110
	80x20	79,4	69,32	50	65	176	125	145	13,5	165	120	25	190	40	34	5	25	130
	80x40	79,4	72,68	50	65	176	125	145	13,5	165	120	25	190	80	34	5	25	130
	80x60	79,4	72,68	50	65	176	125	145	13,5	165	120	25	190	120	34	5	25	130

An increased screw (such as ZE-150-RN with screw 80x20) can also be used for the rotating version

1) Depending on the control system and drive, the dimension L3 can be reduced at your own discretion. An extension may be required if a bellows or spiral spring is fitted

2) Dynamic load rating to DIN ISO 3408

3) Non-preferred design

4) Reduced play 0,02 mm available on request

KGT R 250 to 350 kN  
KGT-R | rotating screw

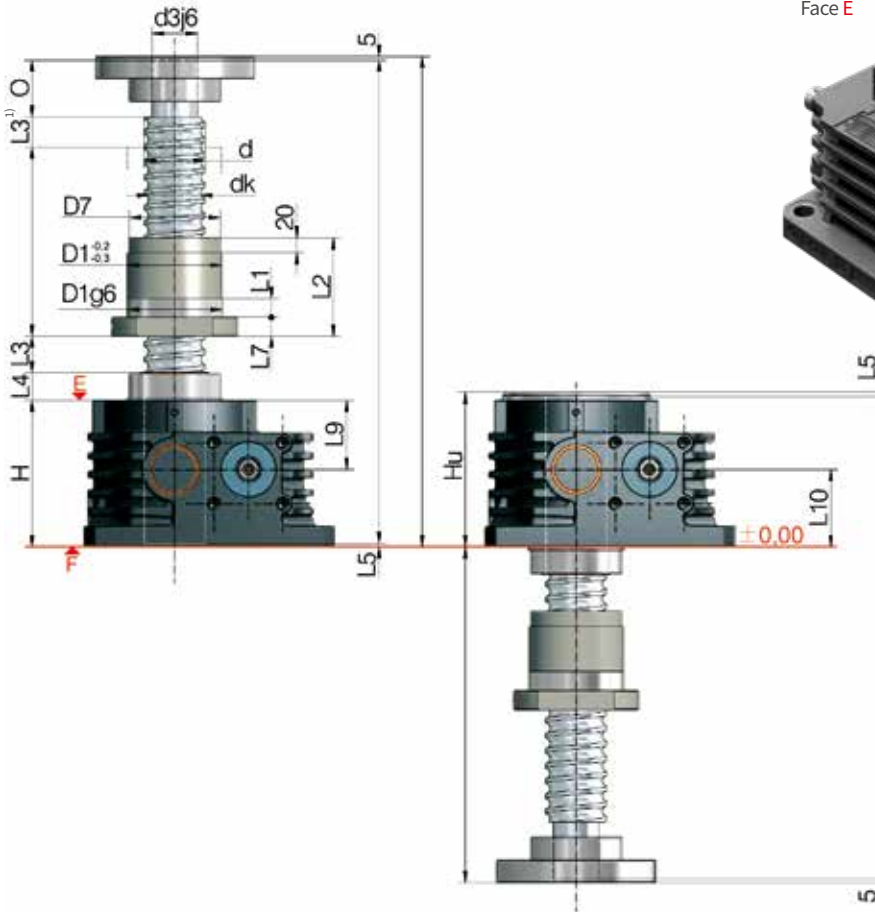

**Position of the flanged nut:**  
G = flange gearbox side (as shown)  
S = flange screw side

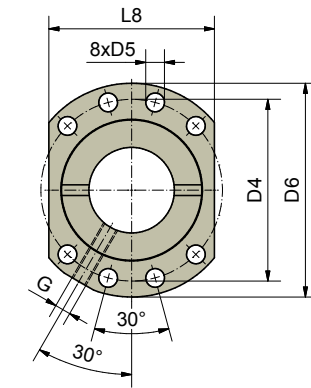

Hole pattern 2 to DIN 69051

Screw jacks	KGT Screw ØxP	Stroke per drive revolution		KGT Load rating kN		Nut Type	Nut Hole pattern	Lubrication hole G	Axial play max <sup>9)</sup> mm
		RN	RL	dyn. C <sup>2)</sup>	stat. Co=C <sub>0a</sub>				
Z-250	80x10 <sup>4)</sup>	0,94	0,31	193	993,4	E	2	M8x1	0,03
	80x20	1,87	0,63	359,2	942,5	E	2	M8x1	0,03
	80x40	3,75	1,25	251,2	565,5	E	2	M8x1	0,03
	80x60	5,62	1,88	189,1	377	E	2	M8x1	0,03
Z-350	100x20	1,87	0,63	330,2	979,1	E	2	M8x1	0,03
	100x40	3,75	1,25	270	734	E	2	M8x1	0,03
	100x60	5,62	1,88	203	489,6	E	2	M8x1	0,03
	100x80	7,50	2,50	203	489,6	E	2	M8x1	0,03

# Technical data

## Z-250-R

max. compressive/tensile force, static:	250 kN (25 t)
Input speed:	1500 rpm / max. 1800 rpm
Gearbox operating temperature:	max. 60°C, higher on request
Moment of inertia:	N: 53,8 kg cm <sup>2</sup> / L: 22,0 kg cm <sup>2</sup>
Input torque (at 1500 rpm):	max. 152 Nm (N) / max. 41,4 Nm (L)
Drive-through torque:	max. 770 Nm
Gear ratio:	10,66:1 (Normal) / 32:1 (Low)
Housing material:	GGG-50, corrosion-resistant
Worm shaft:	steel, case-hardened, ground
Weight of screw jack body:	59 kg

## Z-350-R

max. compressive/tensile force, static:	350 kN (35 t)
Input speed:	1000 rpm / max. 1200 rpm
Gearbox operating temperature:	max. 60°C, higher on request
Moment of inertia:	N: 148,9 kg cm <sup>2</sup> / L: 66,1 kg cm <sup>2</sup>
Input torque (at 1500 rpm):	max. 265 Nm (N) / max. 100 Nm (L)
Drive-through torque:	max. 1800 Nm
Gear ratio:	10,66:1 (Normal) / 32:1 (Low)
Housing material:	GGG-50, corrosion-resistant
Worm shaft:	steel, case-hardened, ground
Weight of screw jack body:	112 kg

### Ordering example: Z-250-RN-E-KGT 80x40, C = 251,2 kN - G

Screw Face E or F

Dynamic load rating C

Nut flange

G: flange gearbox side

S: flange screw side

Because of the lack of friction, a holding brake is necessary: a motor brake or a spring pressure brake is required.

**Screw:** 1.1213 (Cf 53), induction hardened and polished.

Screw jacks	KGT Screw							Dimensions mm													
	ØxP	d	dk	d3j6	O	H	Hu	D1	D4	D5	D6	D7	L1	L2	L3 <sup>1)</sup>	L4	L5	L7	L8	L9	L10
Z-250	80x10 <sup>4)</sup>	80	73,6	60	75	193	204	105	125	13,5	145	-	16	160	20	37	5	20	110	91	102
	80x20	80	67	60	75	193	204	125	145	13,5	165	120	25	190	40	37	5	25	130	91	102
	80x40	80	67	60	75	193	204	125	145	13,5	165	120	25	190	80	37	5	25	130	91	102
	80x60	80	67	60	75	193	204	125	145	13,5	165	120	25	190	120	37	5	25	130	91	102
Z-350	100x20	100	87,4	80	100	230	230	150	176	17,5	202	145	25	175	40	24	6	30	155	115	115
	100x40	100	87,4	80	100	230	230	150	176	17,5	202	145	25	175	80	24	6	30	155	115	115
	100x60	100	87,4	80	100	230	230	150	176	17,5	202	145	25	175	120	24	6	30	155	115	115
	100x80	100	87,4	80	100	230	230	150	176	17,5	202	145	25	215	160	24	6	30	155	115	115

1) Depending on the control system and drive, the dimension L3 can be reduced at your own discretion. An extension may be required if a bellows or spiral spring is fitted.

2) Dynamic load rating to DIN ISO 3408

4) Non-preferred design

5) Screw Face F: L2 = 244, L6 = 202



# Technical data

## Z-500-R

max. compressive/tensile force, static:	500 kN (50 t)
Input speed:	1000 rpm / max. 1000 rpm
Gearbox operating temperature:	max. 60°C, higher on request
Moment of inertia:	N: 310,2 kg cm <sup>2</sup> / L: 127,8 kg cm <sup>2</sup>
Input torque (at 1500 rpm):	max. 408 Nm (N) / max. 170 Nm (L)
Drive-through torque:	max. 1940 Nm
Gear ratio:	10,66:1 (Normal) / 32:1 (Low)
Housing material:	GGG-50, corrosion-resistant
Worm shaft:	steel, case-hardened, ground
Weight of screw jack body:	168 kg

## Z-1000-R

max. compressive/tensile force, static:	1000 kN (100 t)
Input speed:	1000 rpm / max. 1000 rpm
Gearbox operating temperature:	max. 60°C, higher on request
Moment of inertia:	N: 1058,2 kg cm <sup>2</sup> / L: 459,2 kg cm <sup>2</sup>
Input torque (at 1500 rpm):	max. 680 Nm (N) / max. 450 Nm (L)
Drive-through torque:	max. 4570 Nm
Gear ratio:	13,33:1 (Normal) / 40:1 (Low)
Housing material:	GGG, corrosion-resistant
Worm shaft:	steel, case-hardened, ground
Weight of screw jack body:	408 kg

## Z-750-R

max. compressive/tensile force, static:	750 kN (75 t)
Input speed:	1000 rpm / max. 1000 rpm
Gearbox operating temperature:	max. 60°C, higher on request
Moment of inertia:	N: 518,1 kg cm <sup>2</sup> / L: 256,1 kg cm <sup>2</sup>
Input torque (at 1500 rpm):	max. 480 Nm (N) / max. 210 Nm (L)
Drive-through torque:	max. 4570 Nm
Gear ratio:	13,33:1 (Normal) / 40:1 (Low)
Housing material:	GGG-50, corrosion-resistant
Worm shaft:	steel, case-hardened, ground
Weight of screw jack body:	262 kg

### Ordering example: Z-1000-RN-E-KGT 160x40, C = 1069,9 kN - G

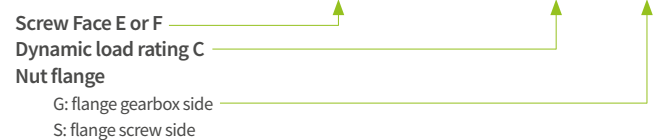

Because of the lack of friction, a holding brake is necessary: a motor brake or a spring pressure brake is required.

**Screw:** 1.1213 (Cf53), induction hardened and polished.

Screw jacks	KGT Screw		Dimensions mm																
	ØxP	d	dk	d3j6	O	H	D1	D4	D5	D6	D7	L1	L2	L3 <sup>1)</sup>	L4	L5	L7	L8	L9
Z-500	125x25	125	107,8	95	120	260	185	212	17,5	240	170	25	250	50	32	6	30	190	130
	125x40	125	107,8	95	120	260	185	212	17,5	240	170	25	250	80	32	6	30	190	130
	125x60	125	107,8	95	120	260	185	212	17,5	240	170	25	180	120	32	6	30	190	130
	125x80	125	112,4	95	120	260	185	212	17,5	240	170	25	220	160	32	6	30	190	130
Z-750	140x25	140	122,8	100	120	310	210	243	22	275	200	25	310	50	37	10	40	215	115
	140x40	140	117	100	120	310	210	243	22	275	200	25	310	80	37	10	40	215	115
	140x60	140	117	100	120	310	225	260	22	295	200	25	280	120	37	10	40	230	115
	140x80	140	117	100	120	310	225	260	22	295	200	25	260	160	37	10	40	230	115
Z-1000	160x25	160	142,8	130	175	340	225	260	22	295		25	345	50	31	13	40	230	170
	160x40	160	132,8	130	175	340	260	300	22	340	250	40	310	80	31	13	40	265	170
	160x60	160	137	130	175	340	260	300	22	340	250	40	295	120	31	13	40	265	170
	160x80	160	137	130	175	340	260	300	22	340	250	40	275	160	31	13	40	265	170

1) Depending on the control system and drive, the dimension L3 can be reduced at your own discretion. An extension may be required if a bellows or spiral spring is fitted.

2) Dynamic load rating to DIN ISO 3408

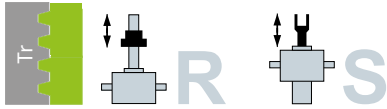

## High performance gearbox ZE-H

Characteristics and duty cycle thermal limit

# 35 TO 200 kN

## ZE-H Series Features

- 1 **Higher performance possible:**  
In comparison to standard gearboxes, the ZE-H series can drive significantly higher loads at the same speed, or higher higher speeds at the same load
- 2 **Higher operating cycle possible**
- 3 **Speed of up to 3000 rpm**
- 4 **Optimised gearing with increased lifetime, manufactured on high-precision gear cutting and grinding machines**
- 5 **Full synthetic worm gear oil**
- 6 **Spindle grease optimized for high performance**
- 7 **Improved temperature endurance during both continuous and peak loads**
- 8 **High quality gaskets**
- 9 **Simplified maintenance when changing the lubricant:**  
If necessary, an easy oil change is possible



These curves are for guidance under standard industrial conditions (ambient temperature etc.) and correct maintenance (lubrication etc.). They are based on the ZIMM standard trapezoidal thread. With the use of a ball screw, the operation cycles can be many times longer.

**ZE-H 35 Oil lubricated with 7:1 ratio**

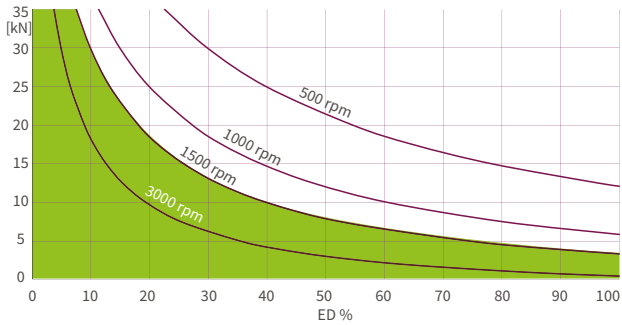

**ZE-H 35 Oil lubricated 28:1 ratio**

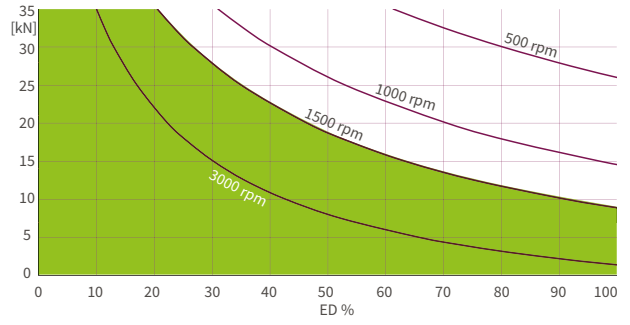

**ZE-H 50 Oil lubricated with 7:1 ratio**

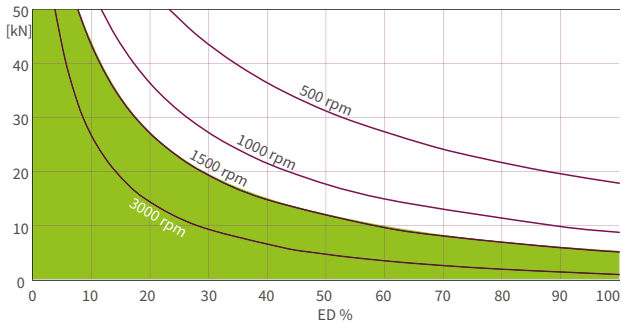

**ZE-H 50 Oil lubricated 28:1 ratio**

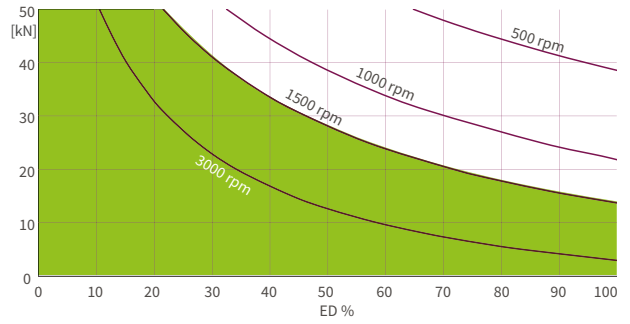

**ZE-H 100 Oil lubricated with 9:1 ratio**

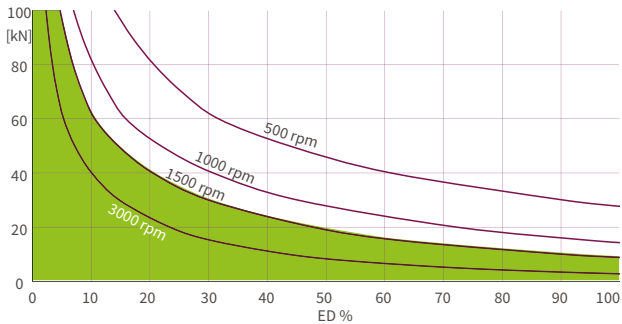

**ZE-H 100 Oil lubricated 36:1 ratio**

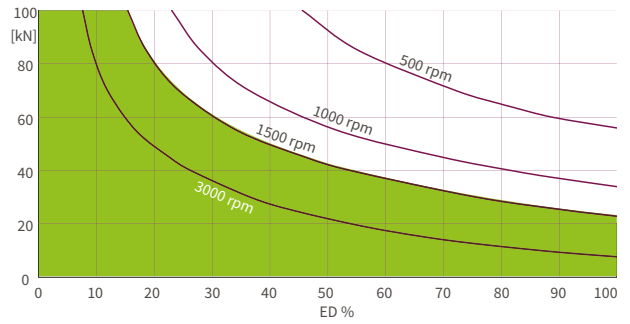

**ZE-H 150 Oil lubricated with 9:1 ratio**

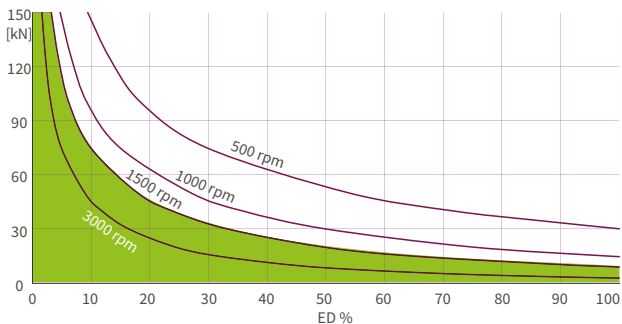

**ZE-H 150 Oil lubricated 36:1 ratio**

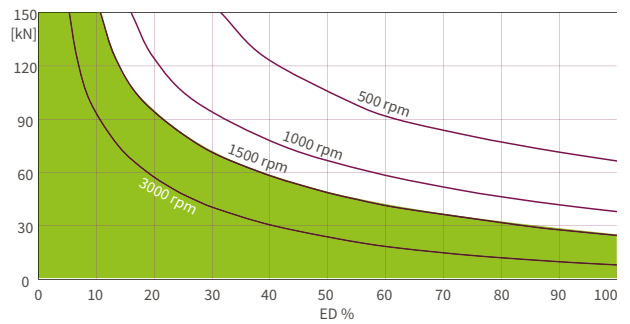

**ZE-H 200 Oil lubricated with 8:1 ratio**

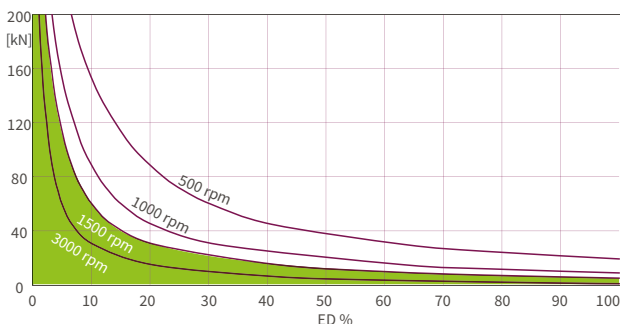

**ZE-H 200 Oil lubricated 24:1 ratio**

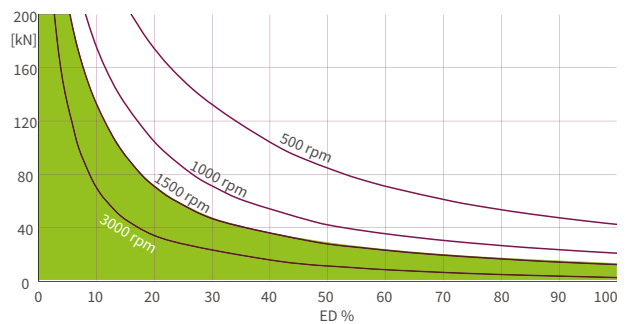

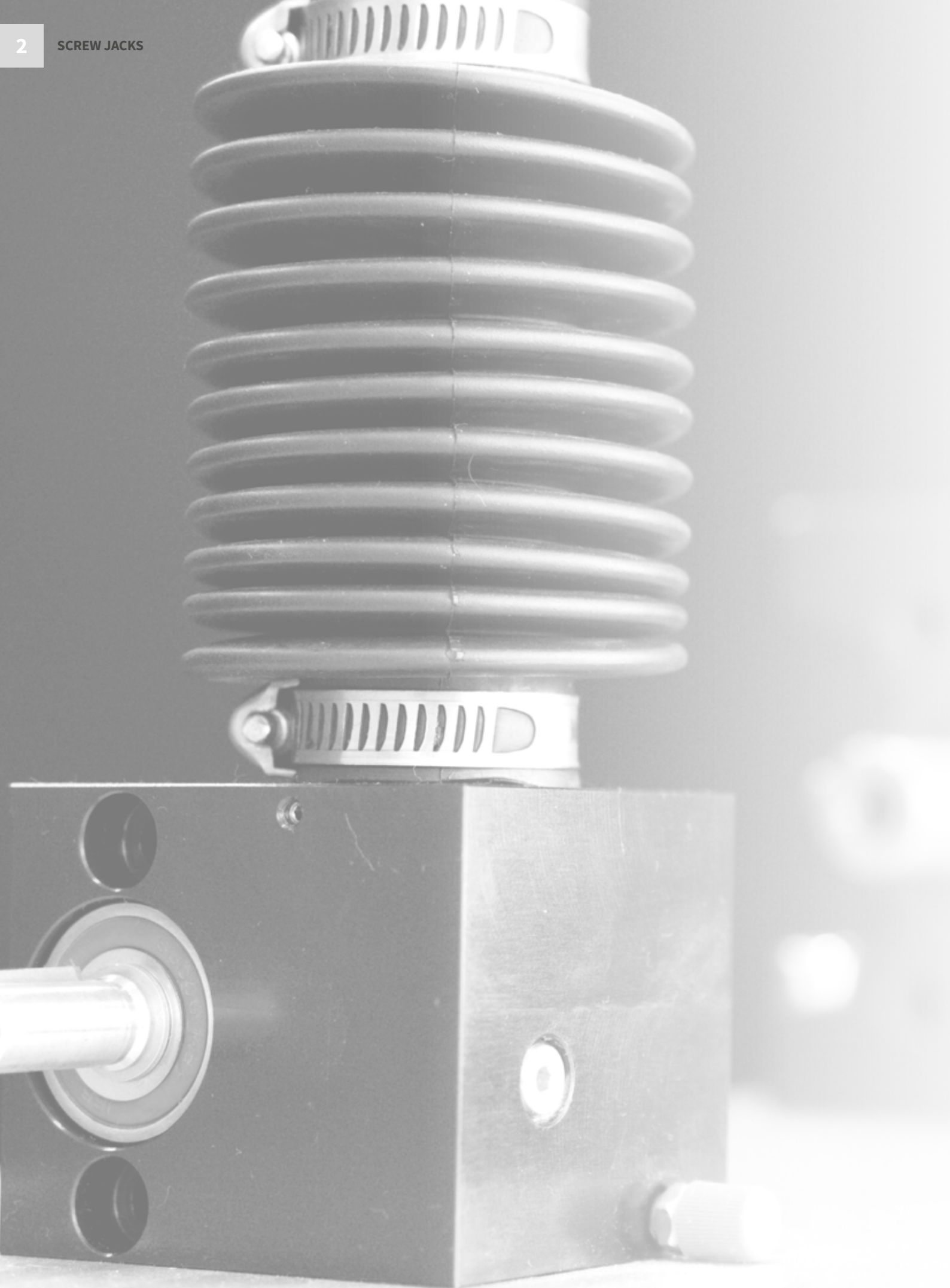



# CHAPTER 2 | GSZ-SERIES

## Cubic screw jacks series

<b>Tr</b>	<b>Trapezoidal screw (Tr), S + R-Version</b>	
	GSZ-Series (Tr), S + R-Version, 2,5 kN	72
	GSZ-Series (Tr) Bevel gearbox (KSZ-2) Accessories for GSZ-2,5	76
	GSZ-Series (Tr), S + R-Version, 5 kN	78
	GSZ-Series (Tr), S + R-Version, 10 kN	80
	GSZ-Series (Tr), S + R-Version, 25 kN	82
	GSZ-Series (Tr), S + R-Version, 50 kN	84
	GSZ-Series (Tr), S + R-Version, 100 kN	86
	GSZ-Series (Tr), S + R-Version, 150 kN	88
<b>KGT</b>	<b>Ball screw (KGT), S-Version</b>	
	GSZ-Series (KGT), S-Version, 5 - 25 kN	90
	GSZ-Series (KGT), S-Version, 50 - 150 kN	92
	<b>Ball screw (KGT), R-Version</b>	
	GSZ-Series (KGT), R-Version, 2,5 - 25 kN	94
	GSZ-Series (KGT), R-Version, 50 - 150 kN	96





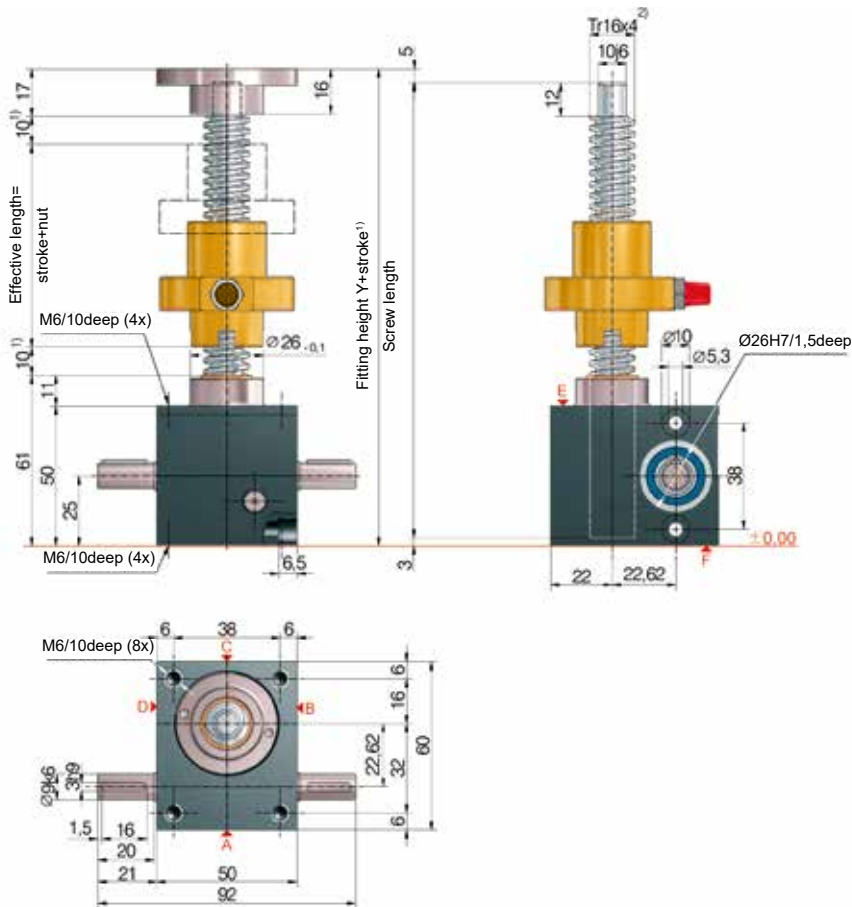

Code	Gearbox (series)	Size	Version (variant)	Ratio	Screw	Stroke per drive shaft rotation
GSZ-2-RN	GSZ	2,5	R (rotating screw)	N (normal) 4:1	Tr 16x4	1,00 mm
GSZ-2-RL				L (low) 16:1		0,25 mm

### Technical data series GSZ-2-S / GSZ-2-R

max. compressive/tensile force, static:	2,5 kN (250 kg)
max. compressive/tensile force, dyn:	see duty cycle curves
Input speed:	1500 rpm / max. 3000 rpm (depending on the load and duty cycle)
Screw size standard:	Tr 16x4 <sup>2)</sup>
Gear ratio:	4:1 (N) / 16:1 (L)
Housing material:	aluminium, corrosion-resistant
Worm shaf:	steel, case-hardened, ground
Weight of screw jack body:	0,6 kg
Weight of screw/m:	1,21 kg
Gearbox lubrication:	synthetic fluid grease
Screw lubrication:	grease lubrication
Gearbox operating temperature:	max. 60°C, higher on request
Moment of inertia:	N: 0,047 kg cm <sup>2</sup> / L: 0,031 kg cm <sup>2</sup>
Input torque (at 1500 rpm):	max. 1,4 Nm (N) / max. 0,5 Nm (L)
Drive-through torque:	max. 9 Nm
Drive torque M <sub>G</sub> (Nm):	F (kN) x 0,52 <sup>3,4)</sup> (N-Normal) F (kN) x 0,15 <sup>3,4)</sup> (L-Low)
Breakaway torque:	Drive torque M <sub>G</sub> x 1,5

Make a plan to keep a safe distance of at least 10 mm between gearbox and nut or between nut and threaded end!

Detailed calculation of the fitting dimensions (bellows, screw, protective tube...) can be conveniently determined with our online configurator: [www.zimm.com](http://www.zimm.com)

#### Important information:

- 1) for bellows extension please check e.g. by online configurator.
- 2) Tr 16x4 is standard, also available: double-pitch, INOX, left-handed, increased screw Tr 18x4 (only for the R-Version)
- 3) factor includes efficiency, ratio and 30% safety
- 4) for a 4 mm screw pitch
- 5) to calculate the length of our protective tube length SRO simply use our online configurator: [www.zimm.com](http://www.zimm.com)

# Bevel gearboxes

## KSZ-2

The KSZ-2 is a bolt-on gearbox and therefore where larger bevel gearboxes such as the KSZ-H series are used the layouts will be different.

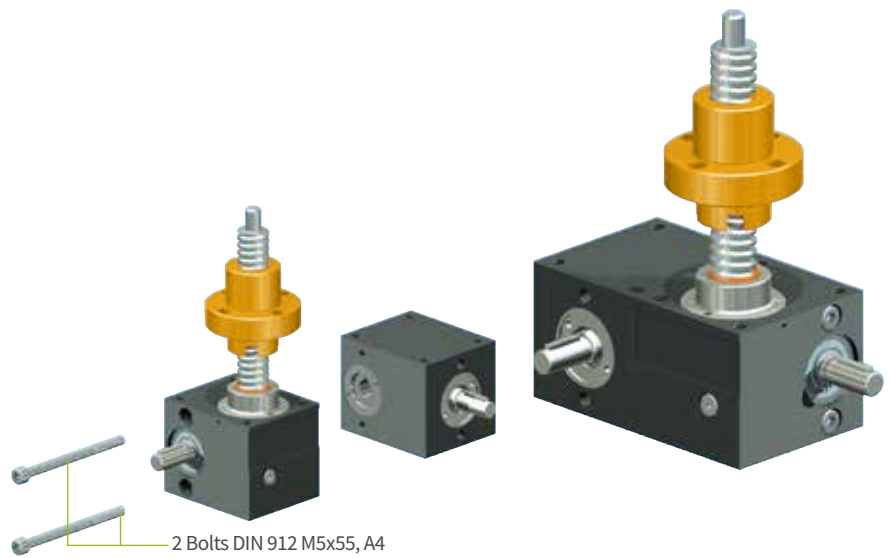

### Layout examples

Other layouts possible.

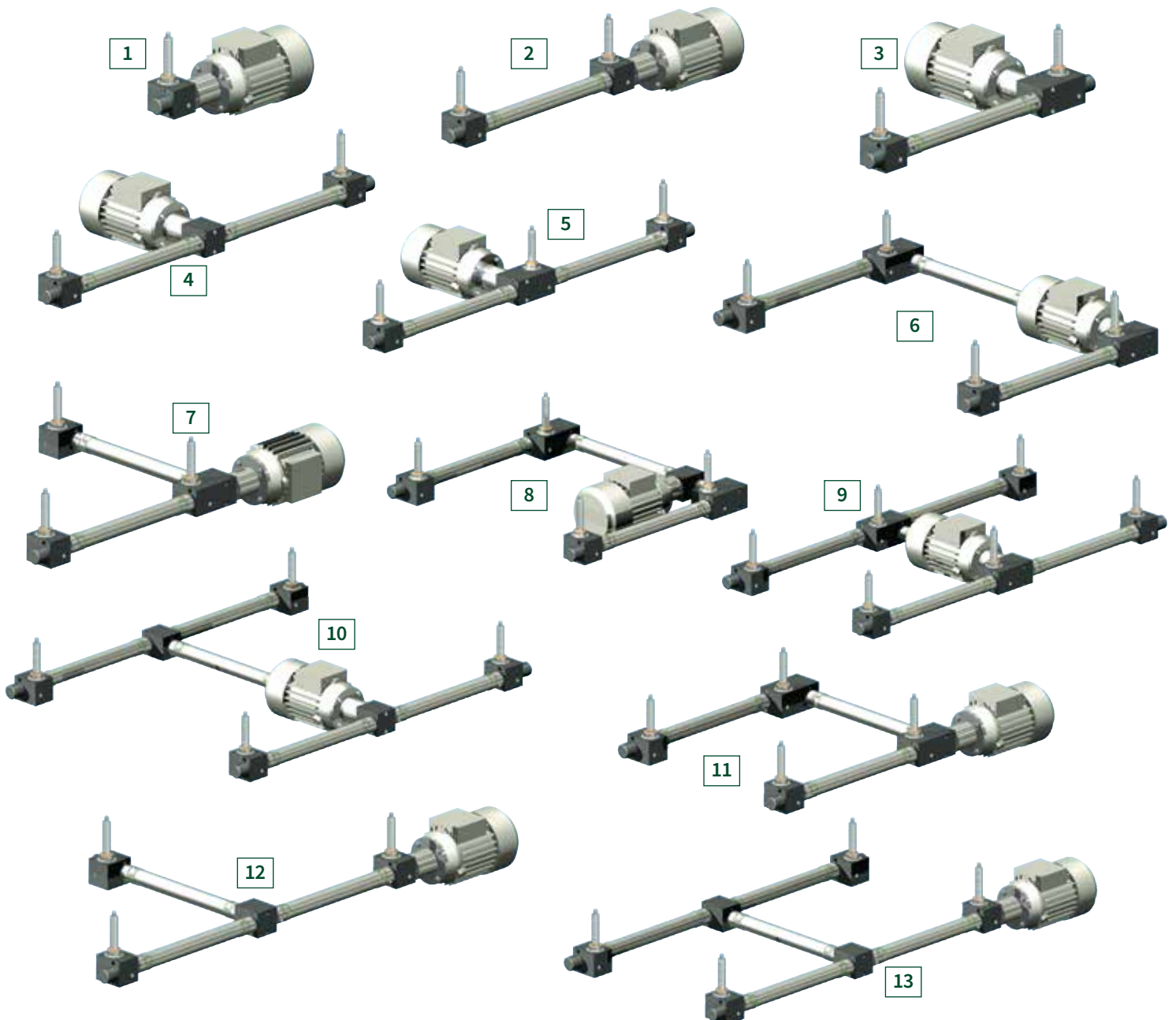

Spiral-toothed

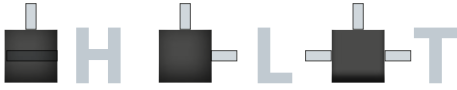

Hollow shaft.

# Bevel gearboxes

## KSZ-2

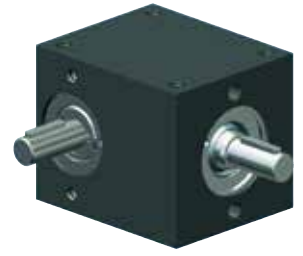

**Spiral-toothed**  
Spiral toothing ensures high torque and low running noise

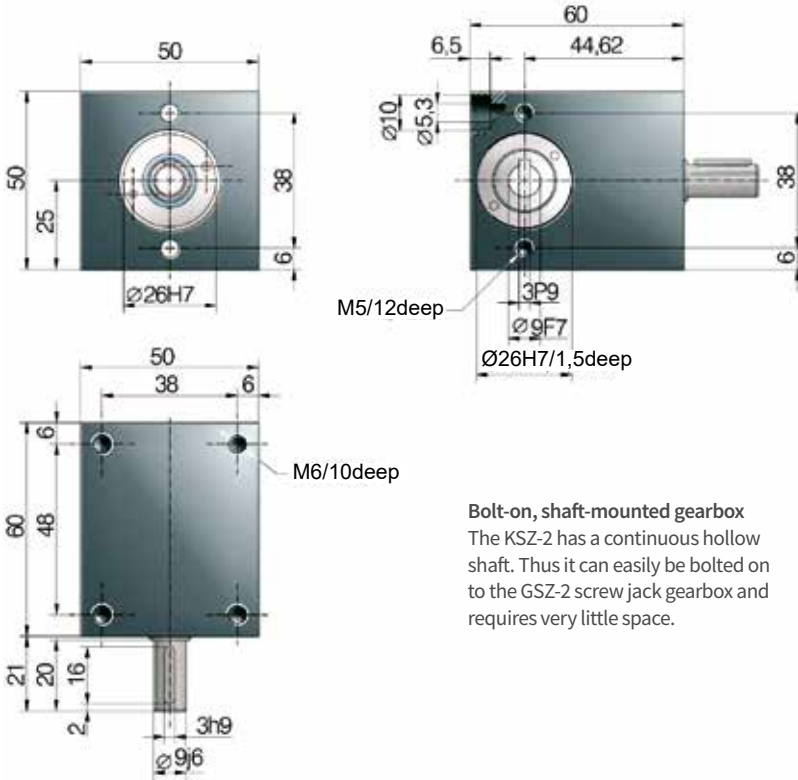

**Bolt-on, shaft-mounted gearbox**  
The KSZ-2 has a continuous hollow shaft. Thus it can easily be bolted on to the GSZ-2 screw jack gearbox and requires very little space.

### Technical data KSZ-2

max. compressive/tensile force, static:	2,5 kN (250 kg)
Input speed:	1500 rpm / max. 3000 rpm
Screw size standard GSZ-2:	Tr 16x4 <sup>2)</sup> (GSZ-2)
Gear ratio:	1:1
Housing material:	aluminium, hard anodised
Worm shaft:	steel, case-hardened, ground
Weight of screw jack body:	0,45 kg
Screw lubrication:	gear oil
Duty cycle:	40%
max. torque:	3 Nm
Drive-through torque:	max. 4,2 Nm



Stub shaft T (long)

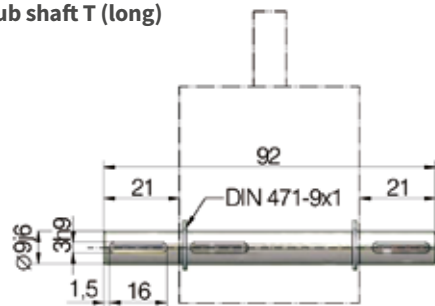

Stub shaft L (short)

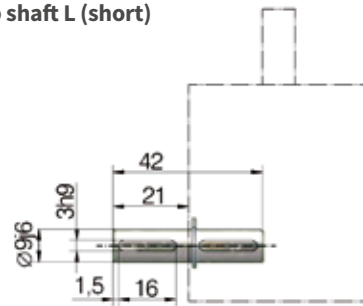

**Note**

Fitting a stub shaft allows the KSZ-2 to be used as a conventional right-angle gearbox

**Ordering example:** KSZ-2 KSZ-2-T KSZ-2-L KSZ-2

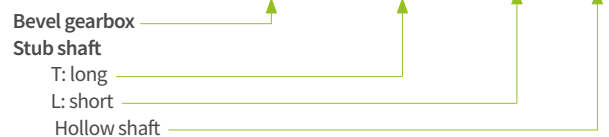

**5 kN**  
**GSZ-5-S** | translating screw

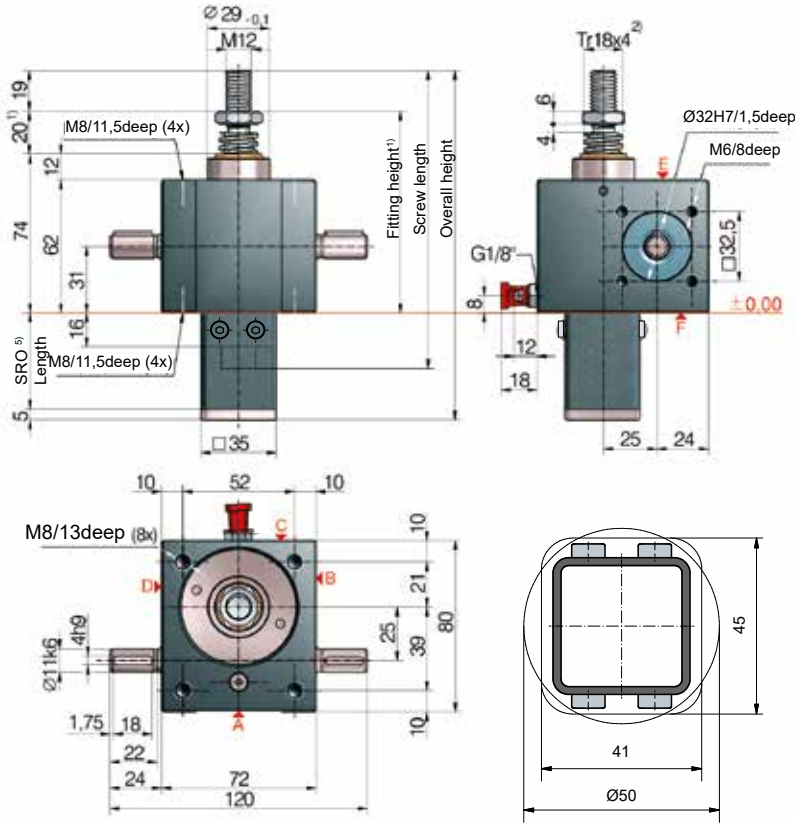

Opening for protective tube square and round

**5) Protective tube length SRO with Tr 18x4-Screw**

Without escape/rotation protection	46 + stroke
Escape/rotation protection	61 + stroke
Rotation protection, with limit switch set ESSET	119 + stroke
Rotation protection and ESSET and KAR	140 + stroke

\*Hinged bearing plate KAR, fitted on face F (below).

**Standard configuration**

Code	Gearbox (series)	Size	Version (variant)	Ratio	Screw	Stroke per drive shaft rotation
GSZ-5-SN	GSZ	5	S (translating screw)	N (normal) 4:1	Tr 18x4	1,00 mm
GSZ-5-SL				L (low) 16:1		0,25 mm

**5 kN**

**Duty cycle thermal limit (S + R)**

Ratio „N“ (4:1)

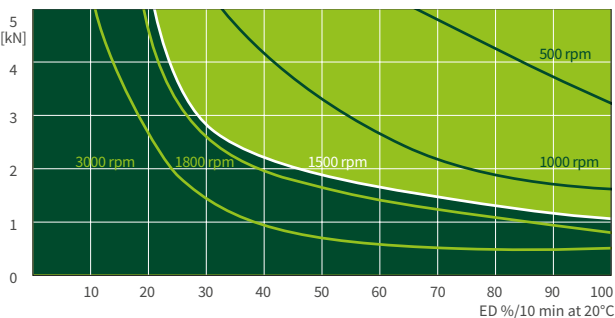

Ratio „L“ (16:1)

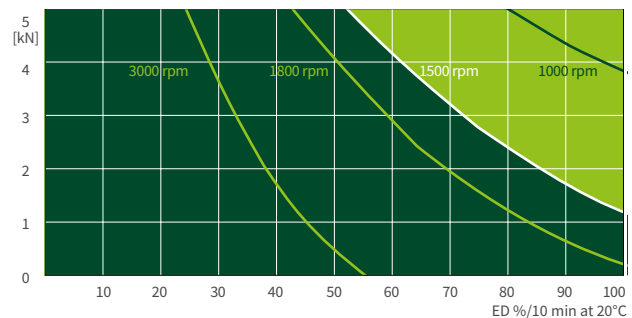

These curves are for guidance under standard industrial conditions (ambient temperature 20°C etc.) and correct maintenance (lubrication etc.). They are based on the ZIMM standard trapezoidal thread Tr 18x4. With the use of a ball screw, the operation cycles can be many times longer.

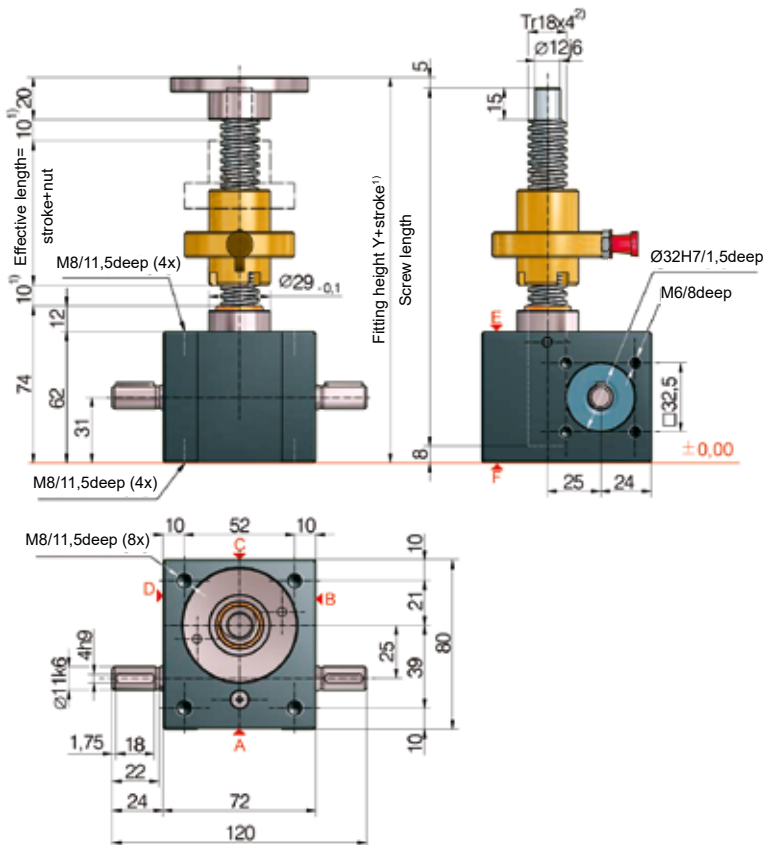

### Standard configuration

Code	Gearbox (series)	Size	Version (variant)	Ratio	Screw	Stroke per drive shaft rotation
GSZ-5-RN	GSZ	5	R (rotating screw)	N (normal) 4:1	Tr 18x4	1,00 mm
GSZ-5-RL				L (low) 16:1		0,25 mm

### Technical data series GSZ-5-S / GSZ-5-R

max. compressive/tensile force, static:	5 kN (0,5 t)
max. compressive/tensile force, dyn.:	see duty cycle curves
Input speed:	1500 rpm / max. 3000 rpm (depending on the load and duty cycle)
Screw size standard:	Tr 18x4 <sup>2)</sup>
Gear ratio:	4:1 (N) / 16:1 (L)
Housing material:	aluminium, corrosion-resistant
Worm shaft:	steel, case-hardened, ground
Weight of screw jack body:	1,2 kg
Weight of screw/m:	1,58 kg
Gearbox lubrication:	synthetic gear oil
Screw lubrication:	grease lubrication
Gearbox operating temperature:	max. 60°C, higher on request
Moment of inertia:	N: 0,132 kg cm <sup>2</sup> / L: 0,091 kg cm <sup>2</sup>
Input torque (at 1500 rpm):	max. 4,7 Nm (N) / max. 1,5 Nm (L)
Drive-through torque:	max. 39 Nm
Drive torque MG (Nm):	F (kN) x 0,62 <sup>3,4)</sup> (N-Normal) F (kN) x 0,21 <sup>3,4)</sup> (L-Low)
Breakaway torque:	Drive torque M <sub>G</sub> x 1,5

Make a plan to keep a safe distance of at least 10 mm between gearbox and nut or between nut and threaded end!

Detailed calculation of the fitting dimensions (bellows, screw, protective tube...) can be conveniently determined with our online configurator: [www.zimm.com](http://www.zimm.com)

#### Important information:

- 1) for bellows extension please check e.g. by online configurator.
- 2) Tr 18x4 is standard, also available: double-pitch, INOX, left-handed, increased screw Tr 20x4 (only for the R-Version)
- 3) factor includes efficiency, ratio and 30% safety
- 4) for a 4 mm screw pitch
- 5) to calculate the length of our protective tube length SRO simply use our online configurator: [www.zimm.com](http://www.zimm.com)

**S 10 kN**  
**GSZ-10-S** | translating screw

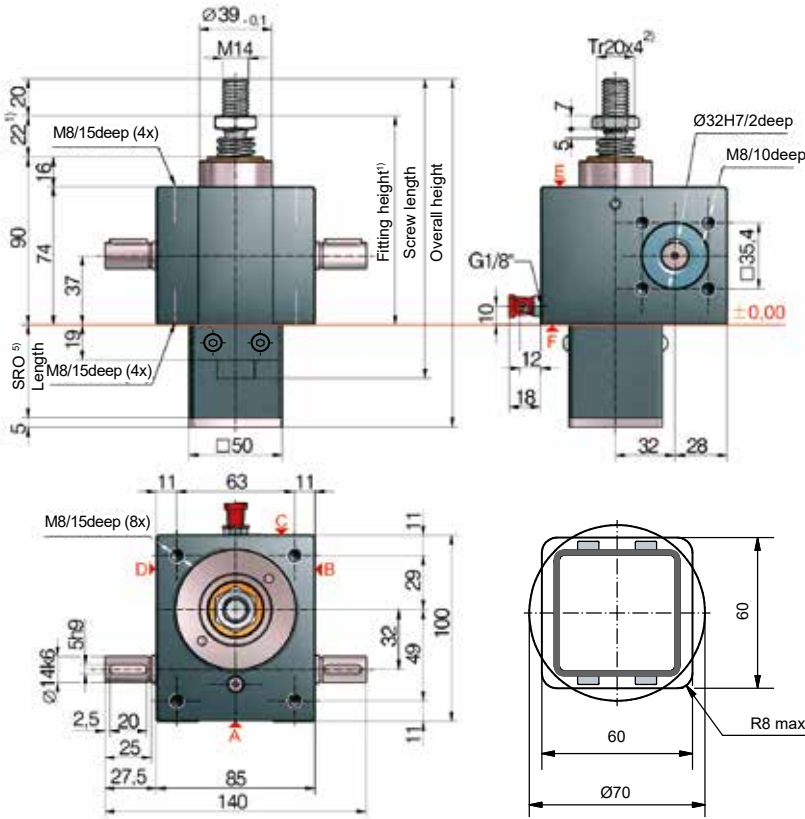

Opening for protective tube square and round

**5) Protective tube length SRO with Tr 20x4-Screw**

Without escape/rotation protection	49 + stroke
Escape/rotation protection	69 + stroke
Rotation protection, with limit switch set ESSET	121 + stroke
Rotation protection and ESSET and KAR	141 + stroke

\*Hinged bearing plate KAR, fitted on face F (below).

**Standard configuration**

Code	Gearbox (series)	Size	Version (variant)	Ratio	Screw	Stroke per drive shaft rotation
GSZ-10-SN	GSZ	10	S (translating screw)	N (normal) 4:1	Tr 20x4	1,00 mm
GSZ-10-SL				L (low) 16:1		0,25 mm

**10 kN**

**Duty cycle thermal limit (S + R)**

Ratio „N“ (4:1)

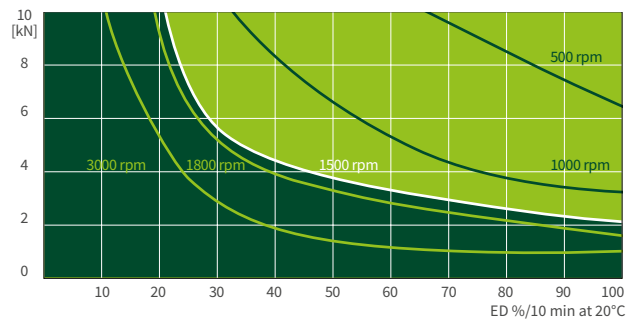

Ratio „L“ (16:1)

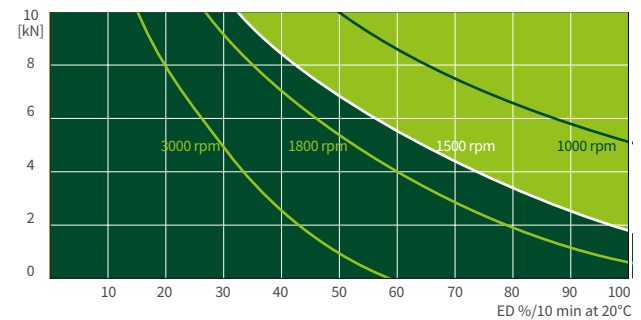

These curves are for guidance under standard industrial conditions (ambient temperature 20°C etc.) and correct maintenance (lubrication etc.). They are based on the ZIMM standard trapezoidal thread Tr 20x4. With the use of a ball screw, the operation cycles can be many times longer.



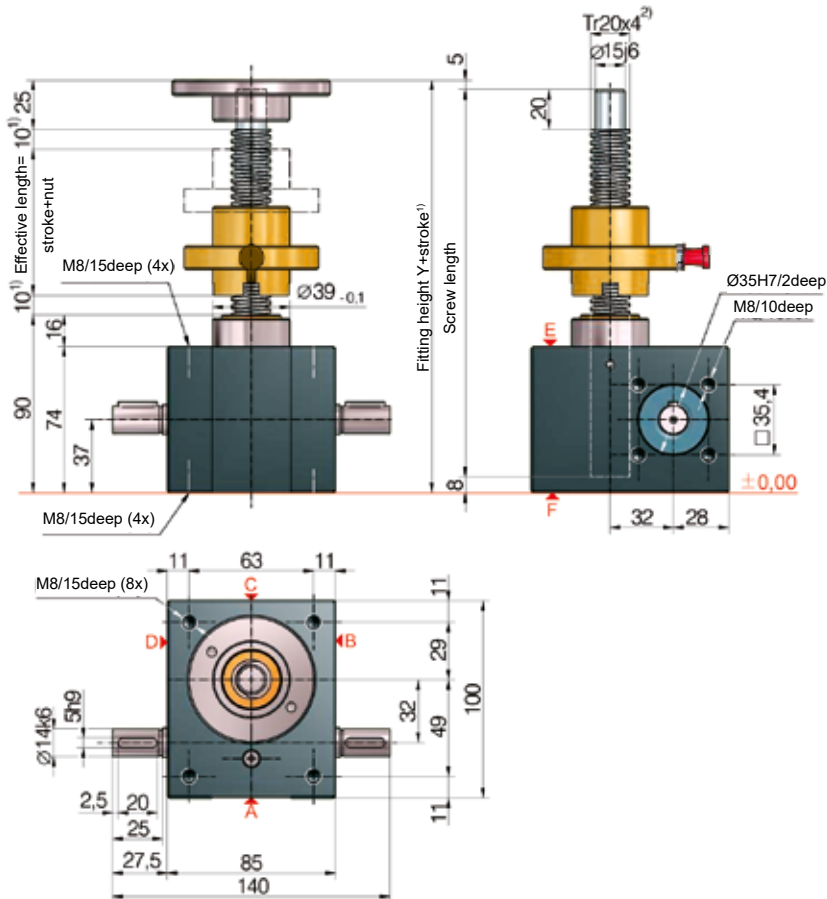

### Standard configuration

Code	Gearbox (series)	Size	Version (variant)	Ratio	Screw	Stroke per drive shaft rotation
GSZ-10-RN	GSZ	10	R (rotating screw)	N (normal) 4:1	Tr 20x4	1,00 mm
GSZ-10-RL				L (low) 16:1		0,25 mm

### Technical data series GSZ-10-S / GSZ-10-R

max. compressive/tensile force, static:	10 kN (1 t)
max. compressive/tensile force, dyn:	see duty cycle curves
Input speed:	1500 rpm / max. 3000 rpm (depending on the load and duty cycle)
Screw size standard:	Tr 20x4 <sup>2)</sup>
Gear ratio:	4:1 (N) / 16:1 (L)
Housing material:	aluminium, corrosion-resistant
Worm shaft:	steel, case-hardened, ground
Weight of screw jack body:	2,1 kg
Weight of screw/m:	2 kg
Gearbox lubrication:	synthetic gear oil
Screw lubrication:	grease lubrication
Gearbox operating temperature:	max. 60°C, higher on request
Moment of inertia:	N: 0,361 kg cm <sup>2</sup> / L: 0,226 kg cm <sup>2</sup>
Input torque (at 1500 rpm):	max. 13,5 Nm (N) / max. 7,5 Nm (L)
Drive-through torque:	max. 57 Nm
Drive torque M <sub>G</sub> (Nm):	F (kN) x 0,64 <sup>3,4)</sup> (N-Normal) F (kN) x 0,20 <sup>3,4)</sup> (L-Low)
Breakaway torque:	Drive torque M <sub>G</sub> x 1,5

Make a plan to keep a safe distance of at least 10 mm between gearbox and nut or between nut and threaded end!

Detailed calculation of the fitting dimensions (bellows, screw, protective tube...) can be conveniently determined with our online configurator: [www.zimm.com](http://www.zimm.com)

#### Important information:

- 1) for bellows extension please check e.g. by online configurator.
- 2) Tr 20x4 is standard, also available: double-pitch, INOX, left-handed, increased screw Tr 30x6 (only for the R-Version)
- 3) factor includes efficiency, ratio and 30% safety
- 4) for a 4 mm screw pitch
- 5) to calculate the length of our protective tube length SRO simply use our online configurator: [www.zimm.com](http://www.zimm.com)

**S 25 kN**  
**GSZ-25-S | translating screw**

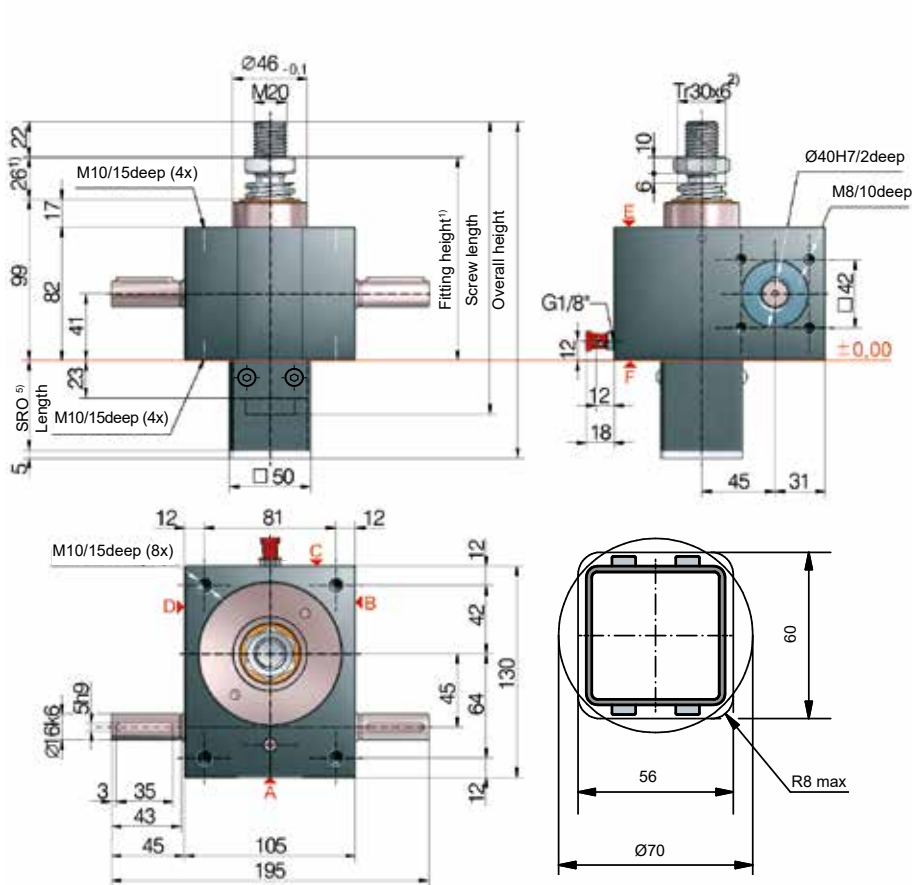

**5) Protective tube length SRO with Tr 30x6-Screw**

Without escape/rotation protection	53 + stroke
Escape/rotation protection	73 + stroke
Rotation protection, with limit switch set ESSET	125 + stroke
Rotation protection and ESSET and KAR	149 + stroke

\*Hinged bearing plate KAR, fitted on face F (below).

Opening for protective tube square and round

**Standard configuration**

Code	Gearbox (series)	Size	Version (variant)	Ratio	Screw	Stroke per drive shaft rotation
GSZ-25-SN	GSZ	25	S (translating screw)	N (normal) 6:1	Tr 30x6	1,00 mm
GSZ-25-SL				L (low) 24:1		0,25 mm

**25 kN**

**Duty cycle thermal limit (S + R)**

**Ratio „N“ (6:1)**

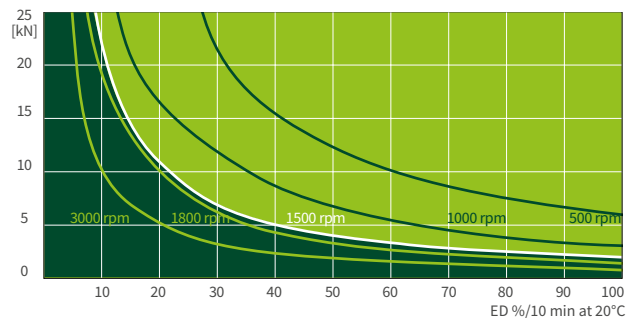

**Ratio „L“ (24:1)**

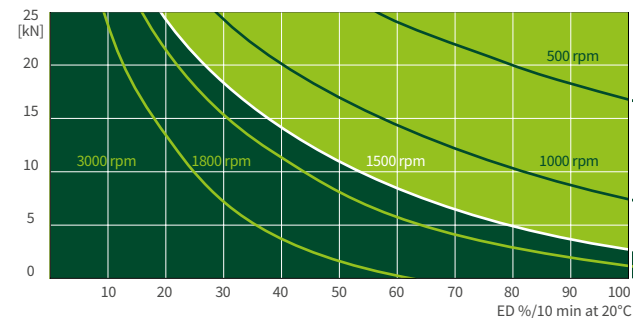

These curves are for guidance under standard industrial conditions (ambient temperature 20°C etc.) and correct maintenance (lubrication etc.). They are based on the ZIMM standard trapezoidal thread Tr 30x6. With the use of a ball screw, the operation cycles can be many times longer.



# R 25 kN

## GSZ-25-R | rotating screw

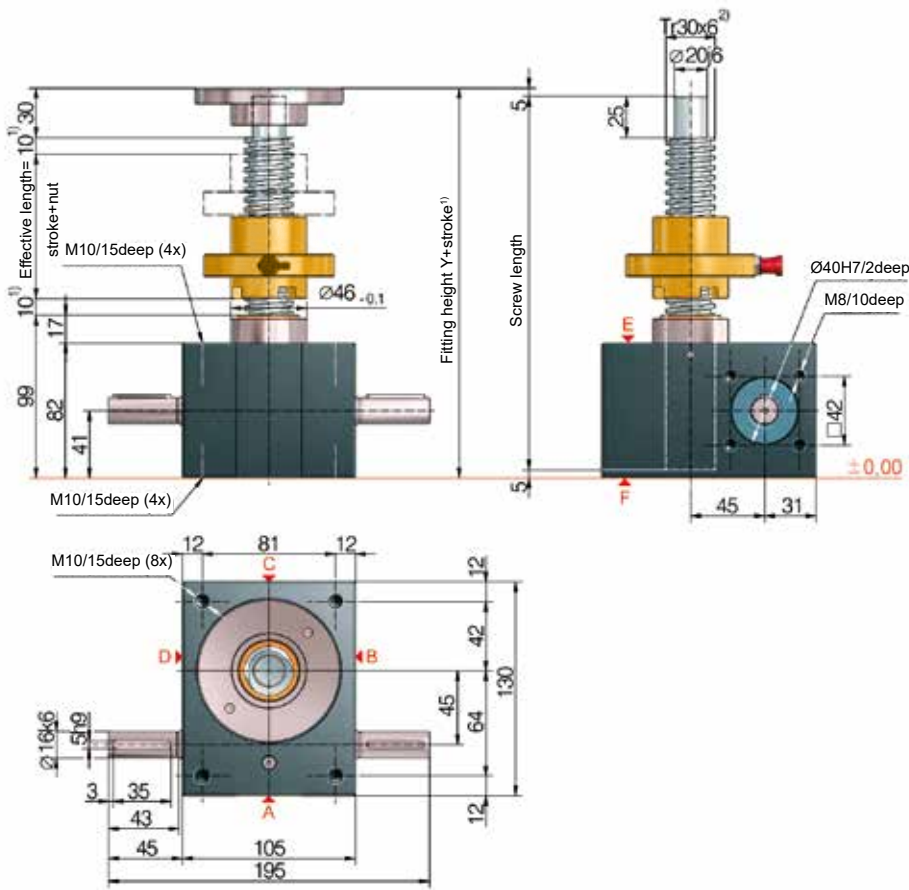

### Standard configuration

Code	Gearbox (series)	Size	Version (variant)	Ratio	Screw	Stroke per drive shaft rotation
GSZ-25-RN	GSZ	25	R (rotating screw)	N (normal) 6:1	Tr 30x6	1,00 mm
GSZ-25-RL				L (low) 24:1		0,25 mm

### Technical data series GSZ-25-S / GSZ-25-R

max. compressive/tensile force, static:	25 kN (2,5 t)
max. compressive/tensile force, dyn:	see duty cycle curves
Input speed:	1500 rpm / max. 3000 rpm (depending on the load and duty cycle)
Screw size standard:	Tr 30x6 <sup>2)</sup>
Gear ratio:	6:1 (N) / 24:1 (L)
Housing material:	aluminium, corrosion-resistant
Worm shaft:	steel, case-hardened, ground
Weight of screw jack body:	3,8 kg
Weight of screw/m:	4,5 kg
Gearbox lubrication:	synthetic gear oil
Screw lubrication:	grease lubrication
Gearbox operating temperature:	max. 60°C, higher on request
Moment of inertia:	N: 0,667 kg cm <sup>2</sup> / L: 0,443 kg cm <sup>2</sup>
Input torque (at 1500 rpm):	max. 18 Nm (N) / max. 10 Nm (L)
Drive-through torque:	max. 108 Nm
Drive torque M <sub>G</sub> (Nm):	F (kN) x 0,63 <sup>3,4)</sup> (N-Normal) F (kN) x 0,20 <sup>3,4)</sup> (L-Low)
Breakaway torque:	Drive torque M <sub>G</sub> x 1,5

Make a plan to keep a safe distance of at least 10 mm between gearbox and nut or between nut and threaded end!

Detailed calculation of the fitting dimensions (bellows, screw, protective tube...) can be conveniently determined with our online configurator: [www.zimm.com](http://www.zimm.com)

#### Important information:

- 1) for bellows extension please check e.g. by online configurator.
- 2) Tr 30x6 is standard, also available: double-pitch, INOX, left-handed, increased screw Tr 40x7 (only for the R-Version)
- 3) factor includes efficiency, ratio and 30% safety
- 4) for a 6 mm screw pitch
- 5) to calculate the length of our protective tube length SRO simply use our online configurator: [www.zimm.com](http://www.zimm.com)

**S** 50 kN  
**GSZ-50-S** | translating screw

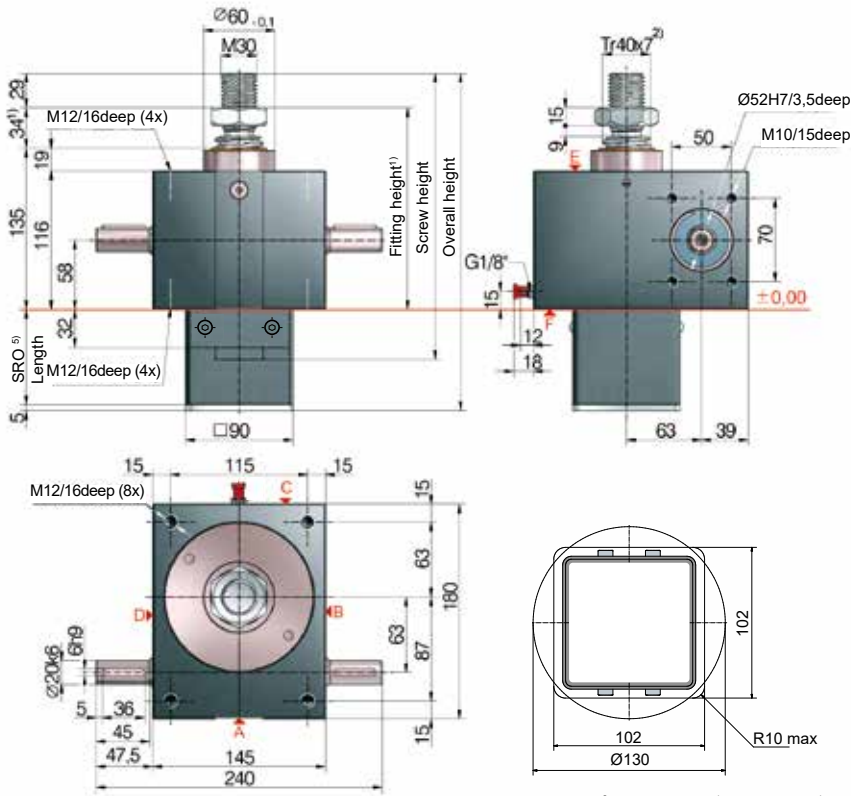

**5) Protective tube length SRO with Tr 40x7-Screw**

Without escape/rotation protection	62 + stroke
Escape/rotation protection	92 + stroke
Rotation protection, with limit switch set ESSET	144 + stroke
Rotation protection and ESSET and KAR*	169 + stroke

\*Hinged bearing plate KAR, fitted on face F (below).

Opening for protective tube square and round

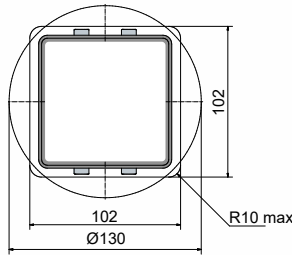

**Standard configuration**

Code	Gearbox (series)	Size	Version (variant)	Ratio	Screw	Stroke per drive shaft rotation
GSZ-50-SN	GSZ	50	S (translating screw)	N (normal) 7:1	Tr 40x7	1,00 mm
GSZ-50-SL				L (low) 28:1		0,25 mm

**50 kN**

**Duty cycle thermal limit (S + R)**

Ratio „N“ (7:1)

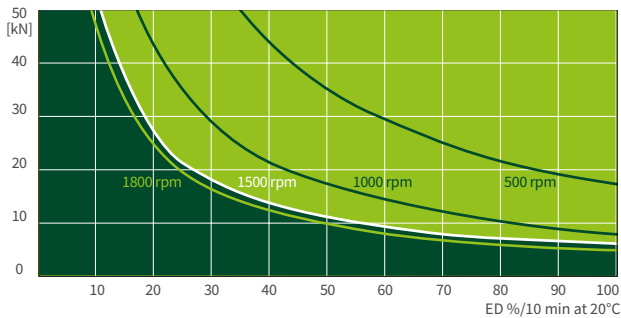

Ratio „L“ (28:1)

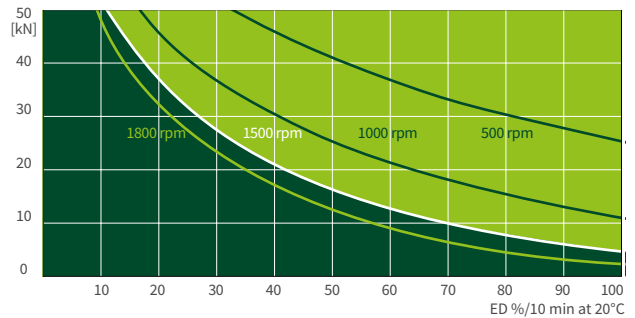

These curves are for guidance under standard industrial conditions (ambient temperature 20°C etc.) and correct maintenance (lubrication etc.). They are based on the ZIMM standard trapezoidal thread Tr 40x7. With the use of a ball screw, the operation cycles can be many times longer.



# R 50 kN

## GSZ-50-R | rotating screw

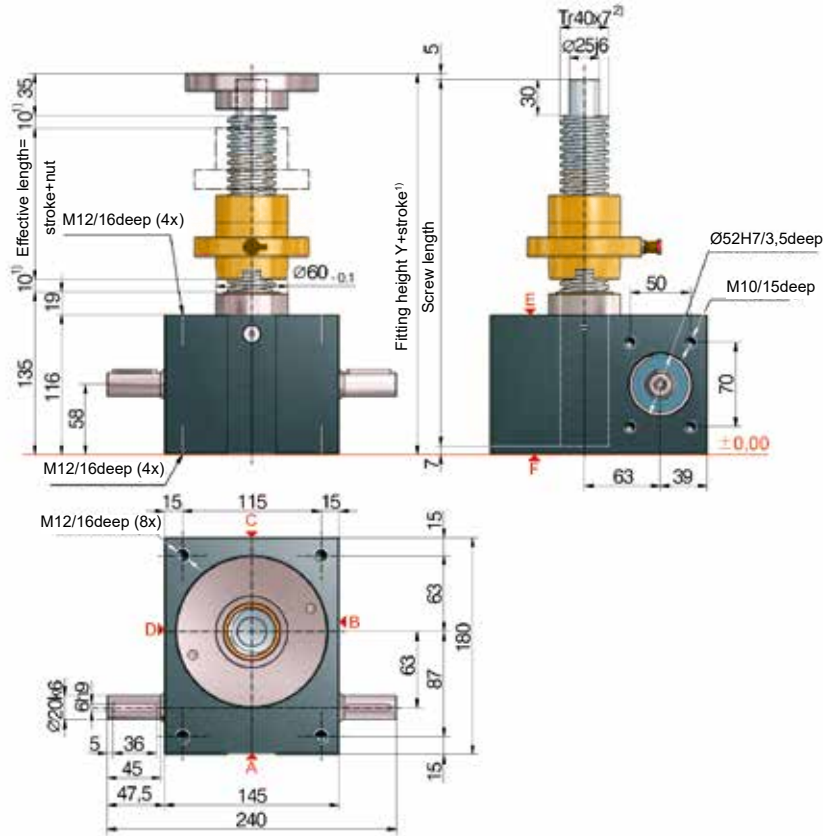

### Standard configuration

Code	Gearbox (series)	Size	Version (variant)	Ratio	Screw	Stroke per drive shaft rotation
GSZ-50-RN	GSZ	50	R (rotating screw)	N (normal) 7:1	Tr 40x7	1,00 mm
GSZ-50-RL				L (low) 28:1		0,25 mm

### Technical data series GSZ-50-S / GSZ-50-R

max. compressive/tensile force, static:	50 kN (5 t)
max. compressive/tensile force, dyn:	see duty cycle curves
Input speed:	1500 rpm / max. 1800 rpm (depending on the load and duty cycle)
Screw size standard:	Tr 40x7 <sup>2)</sup>
Gear ratio:	7:1 (N) / 28:1 (L)
Housing material:	GGG-50, corrosion-resistant
Worm shaft:	steel, case-hardened, ground
Weight of screw jack body:	15 kg
Weight of screw/m:	8 kg
Gearbox lubrication:	synthetic gear oil
Screw lubrication:	grease lubrication
Gearbox operating temperature:	max. 60°C, higher on request
Moment of inertia:	N: 2,49 kg cm <sup>2</sup> / L: 1,73 kg cm <sup>2</sup>
Input torque (at 1500 rpm):	max. 31,5 Nm (N) / max. 10,4 Nm (L)
Drive-through torque:	max. 260 Nm
Drive torque M <sub>G</sub> (Nm):	F (kN) x 0,68 <sup>3,4)</sup> (N-Normal) F (kN) x 0,23 <sup>3,4)</sup> (L-Low)
Breakaway torque:	Drive torque M <sub>G</sub> x 1,5

Make a plan to keep a safe distance of at least 10 mm between gearbox and nut or between nut and threaded end!

Detailed calculation of the fitting dimensions (bellows, screw, protective tube...) can be conveniently determined with our online configurator: [www.zimm.com](http://www.zimm.com)

#### Important information:

- 1) for bellows extension please check e.g. by online configurator.
- 2) Tr 40x7 is standard, also available: double-pitch, INOX, left-handed, increased screw Tr 55x9 (only for the R-Version)
- 3) factor includes efficiency, ratio and 30% safety
- 4) for a 7 mm screw pitch
- 5) to calculate the length of our protective tube length SRO simply use our online configurator: [www.zimm.com](http://www.zimm.com)

**S 100 kN**  
**GSZ-100-S** | translating screw

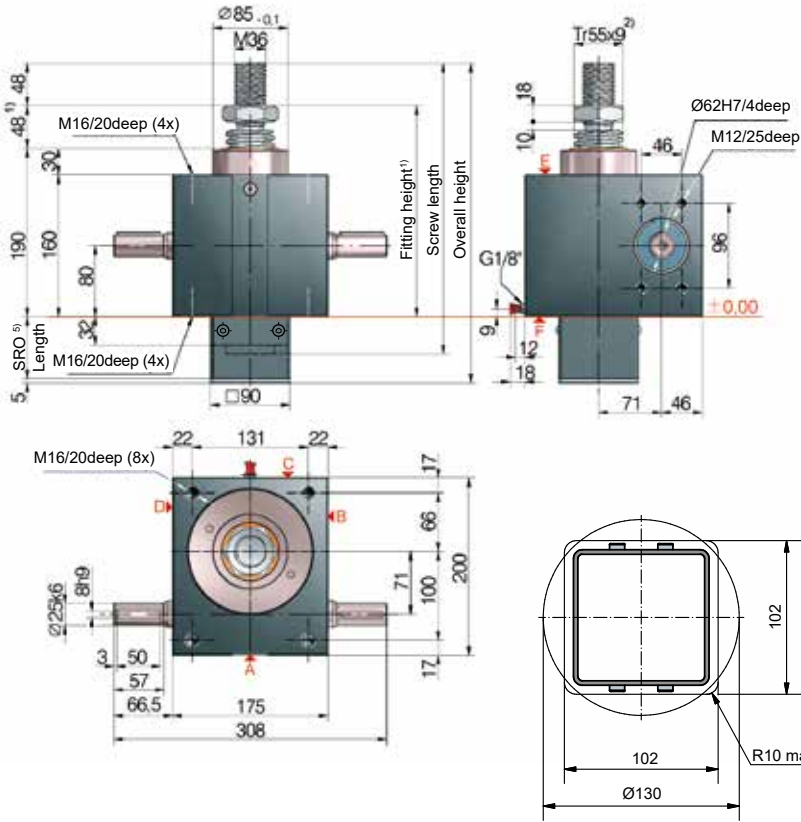

**5) Protective tube length SRO with Tr 55x9-Screw**

Without escape/rotation protection	82 + stroke
Escape/rotation protection	112 + stroke
Rotation protection, with limit switch set ESSET	144 + stroke
Rotation protection and ESSET and KAR*	169 + stroke

\*Hinged bearing plate KAR, fitted on face F (below).

Opening for protective tube square and round

**Standard configuration**

Code	Gearbox (series)	Size	Version (variant)	Ratio	Screw	Stroke per drive shaft rotation
GSZ-100-SN	GSZ	100	S (translating screw)	N (normal) 9:1	Tr 55x9	1,00 mm
GSZ-100-SL				L (low) 36:1		0,25 mm

# 100 kN

**Duty cycle thermal limit (S + R)**

Ratio „N“ (9:1)

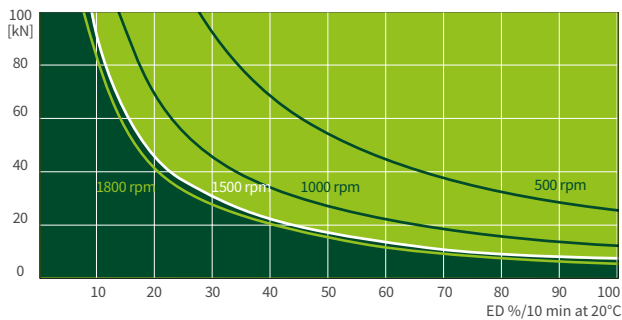

Ratio „L“ (36:1)

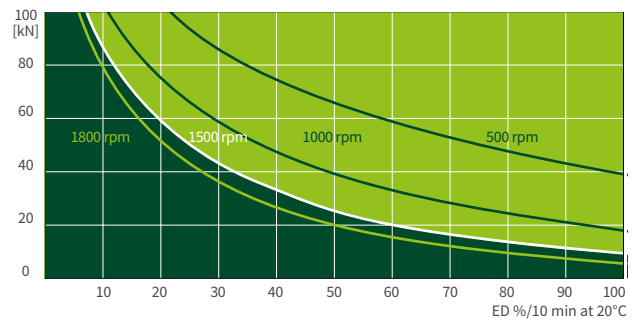

These curves are for guidance under standard industrial conditions (ambient temperature 20°C etc.) and correct maintenance (lubrication etc.). They are based on the ZIMM standard trapezoidal thread Tr 55x9. With the use of a ball screw, the operation cycles can be many times longer.



# R 100 kN

## GSZ-100-R | rotating screw

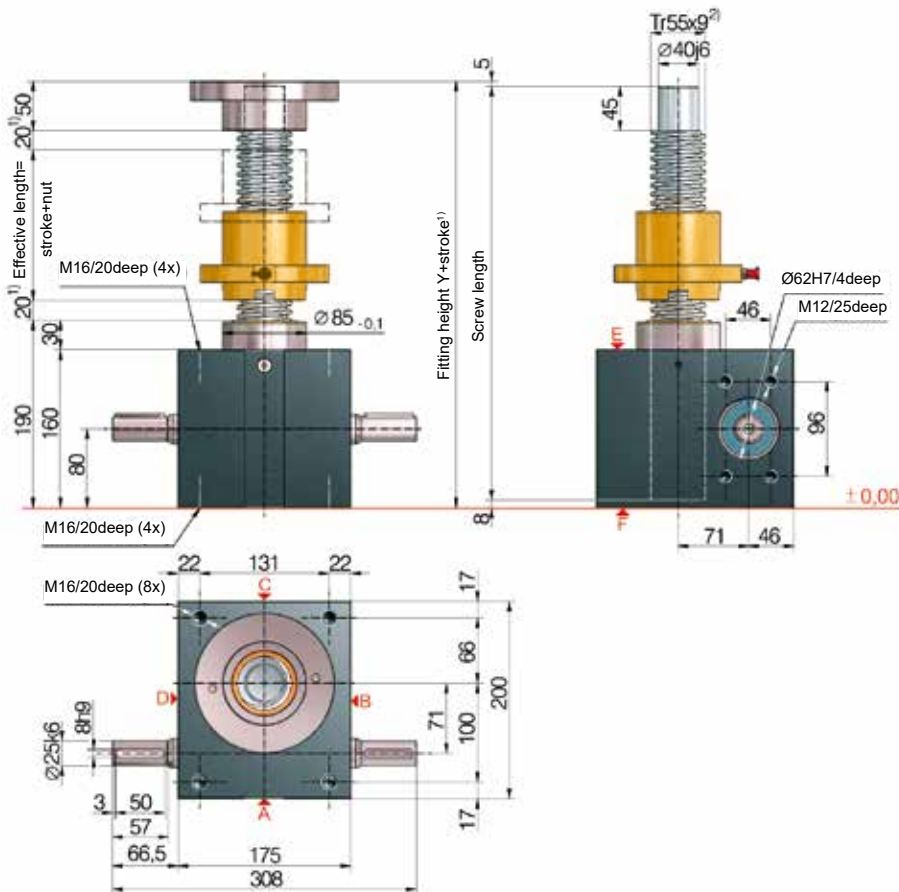

### Standard configuration

Code	Gearbox (series)	Size	Version (variant)	Ratio	Screw	Stroke per drive shaft rotation
GSZ-100-RN	GSZ	100	R (rotating screw)	N (normal) 9:1	Tr 55x9	1,00 mm
GSZ-100-RL				L (low) 36:1		0,25 mm

### Technical data series GSZ-100-S / GSZ-100-R

max. compressive/tensile force, static:	100 kN (10 t)
max. compressive/tensile force, dyn.:	see duty cycle curves
Input speed:	1500 rpm / max. 1800 rpm (depending on the load and duty cycle)
Screw size standard:	Tr 55x9 <sup>2)</sup>
Gear ratio:	9:1 (N) / 36:1 (L)
Housing material:	GGG-50, corrosion-resistant
Worm shaft:	steel, case-hardened, ground
Weight of screw jack body:	30 kg
Weight of screw/m:	15,7 kg
Gearbox lubrication:	synthetic fluid grease
Screw lubrication:	grease lubrication
Gearbox operating temperature:	max. 60°C, higher on request
Moment of inertia:	N: 4,66 kg cm <sup>2</sup> / L: 3,38 kg cm <sup>2</sup>
Input torque (at 1500 rpm):	max. 53,4 Nm (N) / max. 13,5 Nm (L)
Drive-through torque:	max. 540 Nm
Drive torque M <sub>G</sub> (Nm):	F (kN) x 0,72 <sup>3,4)</sup> (N-Normal) F (kN) x 0,23 <sup>3,4)</sup> (L-Low)
Breakaway torque:	Drive torque M <sub>G</sub> x 1,5

Make a plan to keep a safe distance of at least 20 mm between gearbox and nut or between nut and threaded end!

Detailed calculation of the fitting dimensions (bellows, screw, protective tube...) can be conveniently determined with our online configurator: [www.zimm.com](http://www.zimm.com)

#### Important information:

- 1) for bellows extension please check e.g. by online configurator.
- 2) Tr 55x9 is standard, also available: double-pitch, INOX, left-handed, increased screw Tr 60x9 (only for the R-Version)
- 3) factor includes efficiency, ratio and 30% safety
- 4) for a 9 mm screw pitch
- 5) to calculate the length of our protective tube length SRO simply use our online configurator: [www.zimm.com](http://www.zimm.com)

**S 150 kN**  
**GSZ-150-S** | translating screw

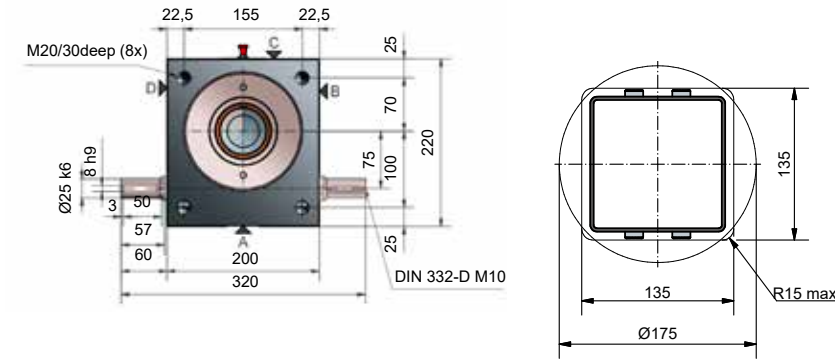
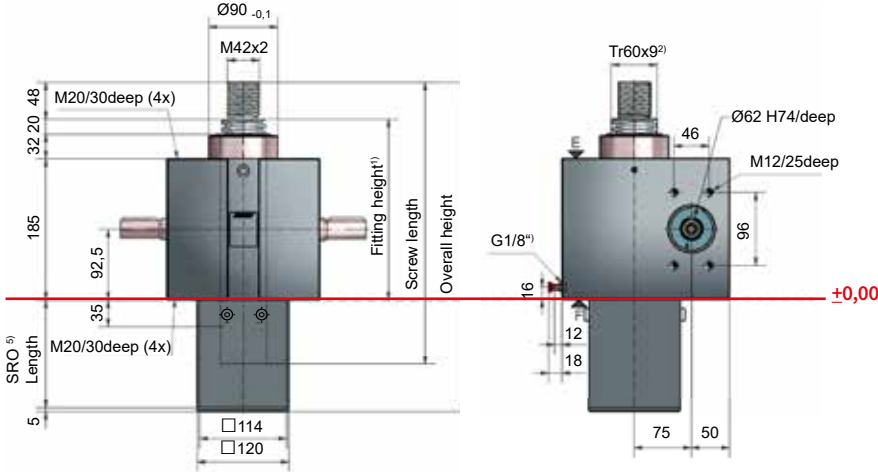

Opening for protective tube square and round

**5) Protective tube length SRO with Tr 60x9-Screw**

Without escape/rotation protection	87 + stroke
Escape/rotation protection	117 + stroke
Rotation protection, with limit switch set ESSET	149 + stroke
Rotation protection, ES and KAR*	199 + stroke

\*Hinged bearing plate KAR, fitted on face F (below).

**Standard configuration**

Code	Gearbox (series)	Size	Version (variant)	Ratio	Screw	Stroke per drive shaft rotation
GSZ-150-SN	GSZ	150	S (translating screw)	N (normal) 9:1	Tr 60x9	1,00 mm
GSZ-150-SL				L (low) 36:1		0,25 mm

**150 kN**

**Duty cycle thermal limit (S + R)**

Ratio „N“ (9:1)

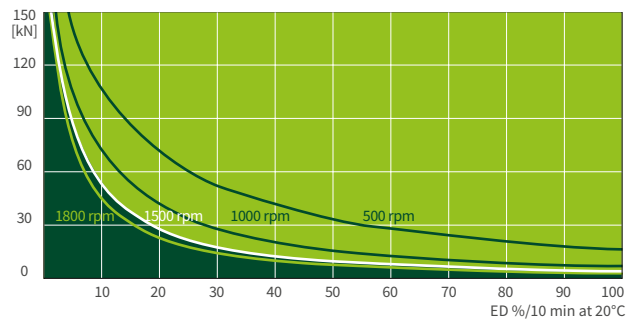

Ratio „L“ (36:1)

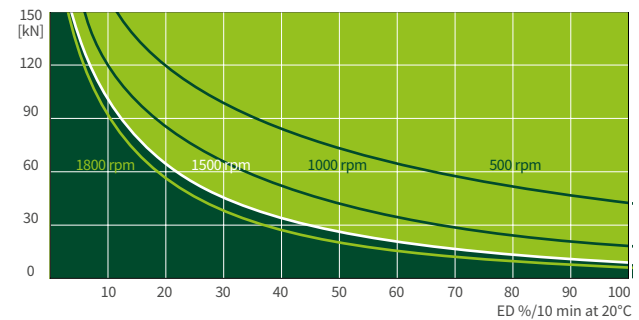

These curves are for guidance under standard industrial conditions (ambient temperature 20°C etc.) and correct maintenance (lubrication etc.). They are based on the ZIMM standard trapezoidal thread Tr 60x9. With the use of a ball screw, the operation cycles can be many times longer.





# 150 kN

## GSZ-150-R | rotating screw

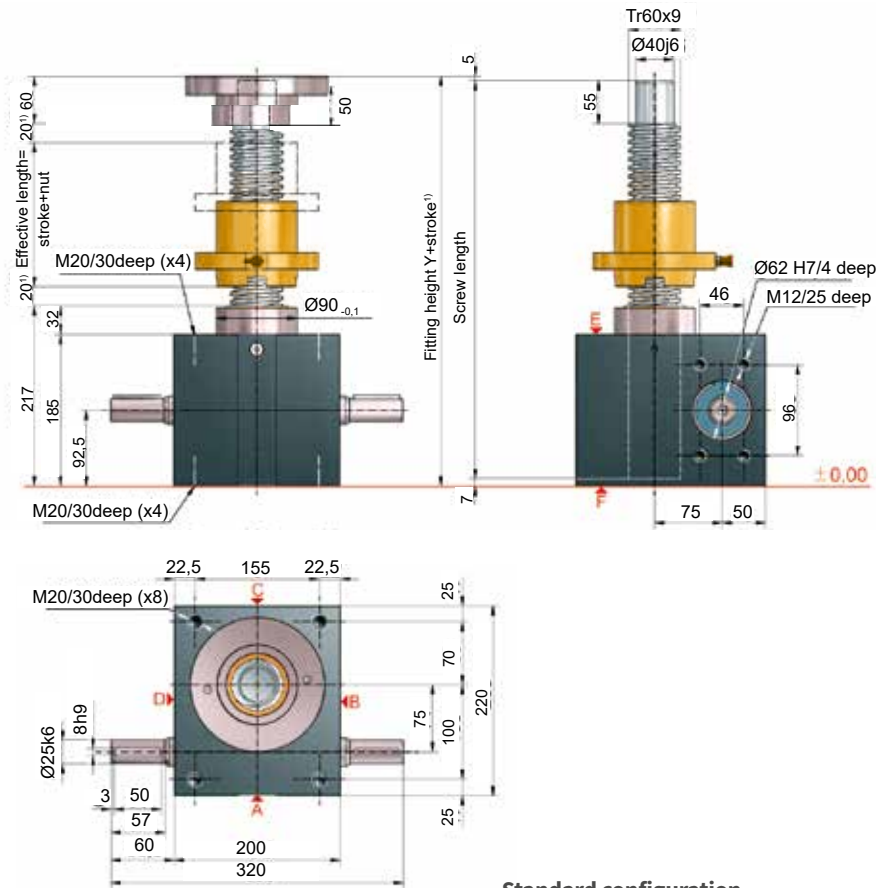

### Standard configuration

Code	Gearbox (series)	Size	Version (variant)	Ratio	Screw	Stroke per drive shaft rotation
GSZ-150-RN	GSZ	150	R (rotating screw)	N (normal) 9:1	Tr 60x9	1,00 mm
GSZ-150-RL				L (low) 36:1		0,25 mm

### Technical data series GSZ-150-S / GSZ-150-R

max. compressive/tensile force, static:	150 kN (15 t)
max. compressive/tensile force, dyn.:	see duty cycle curves
Input speed:	1500 rpm / max. 1800 rpm (depending on the load and duty cycle)
Screw size standard:	Tr 60x9 <sup>2)</sup>
Gear ratio:	9:1 (N) / 36:1 (L)
Housing material:	GGG-50, corrosion-resistant
Worm shaft:	steel, case-hardened, ground
Weight of screw jack body:	42 kg
Weight of screw/m:	19 kg
Gearbox lubrication:	synthetic fluid grease
Screw lubrication:	grease lubrication
Gearbox operating temperature:	max. 60°C, higher on request
Moment of inertia:	N: 7,92 kg cm <sup>2</sup> / L: 5,17 kg cm <sup>2</sup>
Input torque (at 1500 rpm):	max. 75,1 Nm (N) / max. 20,7 Nm (L)
Drive-through torque:	max. 540 Nm
Drive torque M <sub>G</sub> (Nm):	F (kN) x 0,75 <sup>3,4)</sup> (N-Normal) F (kN) x 0,25 <sup>3,4)</sup> (L-Low)
Breakaway torque:	Drive torque M <sub>G</sub> x 1,5

Make a plan to keep a safe distance of at least 20 mm between gearbox and nut or between nut and threaded end!

Detailed calculation of the fitting dimensions (bellows, screw, protective tube...) can be conveniently determined with our online configurator: [www.zimm.com](http://www.zimm.com)

#### Important information:

- 1) for bellows extension please check e.g. by online configurator.
- 2) Tr 60x9 is standard, also available: double-pitch, INOX, left-handed, increased screw Tr 80x16 (only for the R-Version)
- 3) factor includes efficiency, ratio and 30% safety
- 4) for a 9 mm screw pitch
- 5) to calculate the length of our protective tube length SRO simply use our online configurator: [www.zimm.com](http://www.zimm.com)

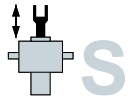

# GSZ 5 to 25 kN

## KGT-S | translating screw

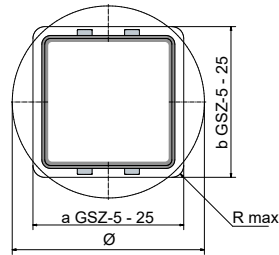
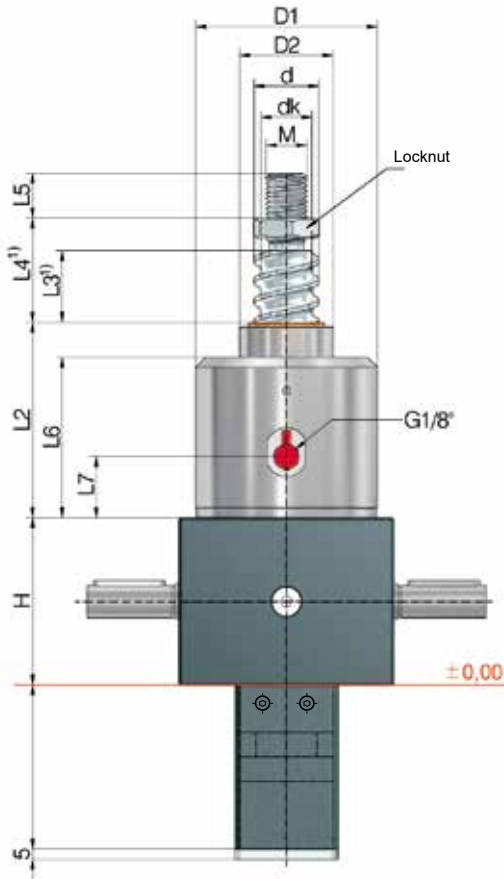

### Opening for protective tube SRO

GSZ-5	GSZ-10	GSZ-25
Protective tube square: a41 x b45, or Ø50		Protective tube square: a60 x b60, R max. 8 or Ø70

VS rotation protection is recommended as standard.

### Protective tube length SRO

Detailed calculation of the fitting dimensions (bellows, screw, protective tube...) can be conveniently determined with our online configurator: [www.zimm.com](http://www.zimm.com)

Screw jacks	KGT Screw	Stroke per drive revolution		KGT Load rating kN		Axial play max <sup>3)</sup> mm
	ØxP	SN	SL	dyn. C <sup>2)</sup>	stat. Co=C <sub>oa</sub>	
GSZ-5	16x5	1,25	0,31	10,1	12	0,06
	16x10	2,50	0,63	11,1	12,9	0,06
GSZ-10	25x5	1,25	0,31	13,7	21,5	0,06
	25x10	2,50	0,63	25,2	45,4	0,06
	25x25	6,25	1,56	20,7	37,3	0,06
GSZ-25	25x50	12,50	3,13	19,2	37,3	0,06
	32x5	0,83	0,21	24,8	49,7	0,06
	32x10	1,67	0,42	30,8	45,6	0,06
	32x20	3,33	0,83	32,9	47,1	0,06
	32x40	6,67	1,67	18,3	37,3	0,06

# Technical data

## GSZ-5-S

max. compressive/tensile force, static:	5 kN (500 kg)
Input speed:	1500 rpm / max. 3000 rpm
Gearbox operating temperature:	max. 60°C, higher on request
Moment of inertia:	N: 0,17 kg cm <sup>2</sup> / L: 0,093 kg cm <sup>2</sup>
Input torque (at 1500 rpm):	max. 4,7 Nm (N) / max. 1,5 Nm (L)
Drive-through torque:	max. 39 Nm
Drive torque:	4:1 (Normal) / 16:1 (Low)
Housing material:	aluminium, corrosion-resistant
Worm shaft:	steel, case-hardened, ground
Weight of screw jack body:	1,5 kg
Gearbox / Screw lubrication:	synthetic gear oil / grease lubrication

## GSZ-25-S

max. compressive/tensile force, static:	25 kN (2,5 t)
Input speed:	1500 rpm / max. 3000 rpm
Gearbox operating temperature:	max. 60°C, higher on request
Moment of inertia:	N: 1,449 kg cm <sup>2</sup> / L: 0,589 kg cm <sup>2</sup>
Input torque (at 1500 rpm):	max. 18 Nm (N) / max. 10 Nm (L)
Drive-through torque:	max. 108 Nm
Drive torque:	6:1 (Normal) / 24:1 (Low)
Housing material:	aluminium, corrosion-resistant
Worm shaft:	steel, case-hardened, ground
Weight of screw jack body:	3,8 kg
Gearbox / Screw lubrication:	synthetic gear oil / grease lubrication

## GSZ-10-S

max. compressive/tensile force, static:	10 kN (1 t)
Input speed:	1500 rpm / max. 3000 rpm
Gearbox operating temperature:	max. 60°C, higher on request
Moment of inertia:	N: 0,641 kg cm <sup>2</sup> / L: 0,271 kg cm <sup>2</sup>
Input torque (at 1500 rpm):	max. 13,5 Nm (N) / max. 7,5 Nm (L)
Drive-through torque:	max. 57 Nm
Drive torque:	4:1 (Normal) / 16:1 (Low)
Housing material:	aluminium, corrosion-resistant
Worm shaft:	steel, case-hardened, ground
Weight of screw jack body:	2,8 kg
Gearbox / Screw lubrication:	synthetic gear oil / grease lubrication

### Ordering example: GSZ-25-SN-KGT 32x10, C = 30,8 kN

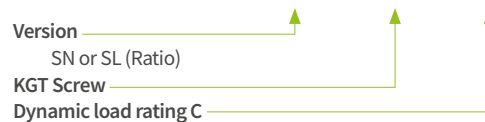

Because of the lack of friction, a holding brake is necessary: a motor brake or a spring pressure brake is required.

**Screw:** 1.1213 (Cf 53), induction hardened and polished.

Screw jacks	KGT Screw ØxP	Dimensions mm											
		H	d	dk	D1	D2	L2	L3 <sup>1)</sup>	L4 <sup>1)</sup>	L5	L6	L7	M
GSZ-5	16x5	62	15,5	12,9	59	29	66	15	25	19	54	23	M12
	16x10	62	15,5	12,9	59	29	66	25	35	19	54	23	M12
GSZ-10	25x5	74	24,5	21,9	69	39	85	15	27	20	69	21	M14
	25x10	74	24,5	21,9	69	39	85	25	37	20	69	21	M14
	25x25	74	24,5	21,9	69	39	85	60	72	20	69	21	M14
GSZ-25	25x50	74	24,5	21,9	69	39	85	125	137	20	69	21	M14
	32x5	82	31,5	28,9	89	46	99	15	31	22	82	33	M20
	32x10	82	31,5	26,8	89	46	99	20	36	22	82	33	M20
	32x20	82	31,5	26,8	89	46	99	35	51	22	82	33	M20
	32x40	82	31,5	28,9	89	46	99	70	86	22	82	33	M20

1) Depending on the control system and drive, the dimension L3 and L4 can be reduced at your own discretion.  
An extension may be required if a bellows or spiral spring is fitted.

2) Dynamic load rating to DIN ISO 3408

3) Reduced play 0,02 mm available on request

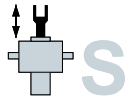

# GSZ 50 to 150 kN

**KGT-S** | translating screw

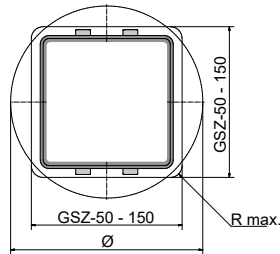
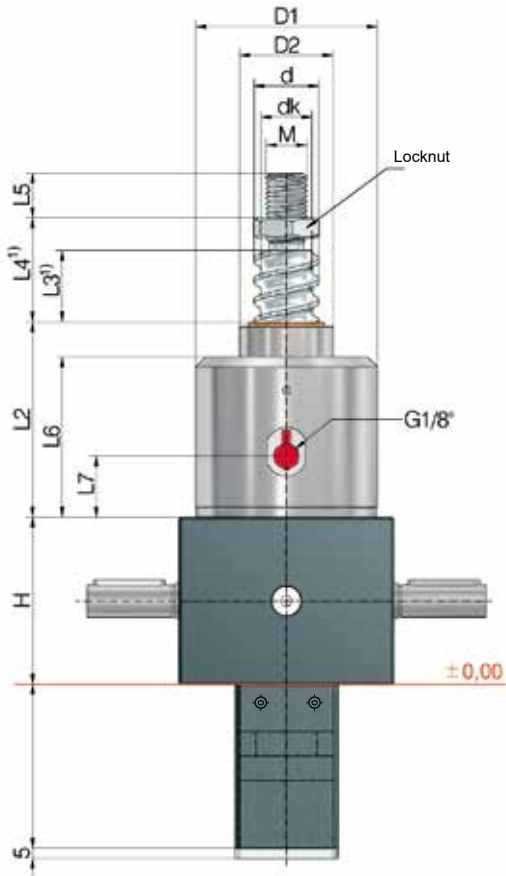

**Opening for protective tube SRO**

**GSZ-50**

**GSZ-100**

**GSZ-150**

Protective tube square:  
102x102, R max. 10 or Ø130

Protective tube square:  
135x135, R max. 15 or Ø175

*VS rotation protection is recommended as standard.*

**Protective tube length SRO**

Detailed calculation of the fitting dimensions (bellows, screw, protective tube...) can be conveniently determined with our online configurator: [www.zimm.com](http://www.zimm.com)

Screw jacks	KGT Screw ØxP	Stroke per drive revolution		KGT Load rating kN		Axial play max <sup>3)</sup> mm
		SN	SL	dyn. C <sup>2)</sup>	stat. Co=C <sub>oa</sub>	
GSZ-50	40x5	0,71	0,18	27,5	63,6	0,06
	40x10	1,43	0,36	46,1	71,3	0,06
	40x20	2,86	0,72	44	80,4	0,06
	40x40	5,71	1,43	35	101,9	0,06
GSZ-100	50x10	1,11	0,28	122,4	248,6	0,06
	50x20	2,22	0,56	127,3	270,3	0,06
	50x40	4,44	1,11	84,7	143,1	0,06
GSZ-150	63x10	1,11	0,28	150,2	598,4	0,03
	63x20	2,22	0,56	173,5	346,2	0,03
	63x40	4,44	1,11	96,6	205,1	0,03
	63x60 <sup>3)</sup>	6,67	1,67	59,5	102,5	0,03

# Technical data

## GSZ-50-S

max. compressive/tensile force, static:	50 kN (5 t)
Input speed:	1500 rpm / max. 1800 rpm
Gearbox operating temperature:	max. 60°C, higher on request
Moment of inertia:	N: 2,85 kg cm <sup>2</sup> / L: 1,75 kg cm <sup>2</sup>
Input torque (at 1500 rpm):	max. 31,5 Nm (N) / max. 10,4 Nm (L)
Drive-through torque:	max. 260 Nm
Gear ratio:	7:1 (Normal) / 28:1 (Low)
Housing material:	GGG-50, corrosion-resistant
Worm shaft:	steel, case-hardened, ground
Weight of screw jack body:	23 kg
Gearbox / Screw lubrication:	synthetic gear oil / grease lubrication

## GSZ-150-S

max. compressive/tensile force, static:	150 kN (15 t)
Input speed:	1500 rpm / max. 1800 rpm
Gearbox operating temperature:	max. 60°C, higher on request
Moment of inertia:	N: 7,92 kg cm <sup>2</sup> / L: 5,17 kg cm <sup>2</sup>
Input torque (at 1500 rpm):	max. 75,1 Nm (N) / max. 20,7 Nm (L)
Drive-through torque:	max. 540 Nm
Gear ratio:	9:1 (Normal) / 36:1 (Low)
Housing material:	GGG-50, corrosion-resistant
Worm shaft:	steel, case-hardened, ground
Weight of screw jack body:	55 kg
Gearbox / Screw lubrication:	synthetic gear oil / grease lubrication

## GSZ-100-S

max. compressive/tensile force, static:	100 kN (10 t)
Input speed:	1500 rpm / max. 1800 rpm
Gearbox operating temperature:	max. 60°C, higher on request
Moment of inertia:	N: 5,45 kg cm <sup>2</sup> / L: 3,43 kg cm <sup>2</sup>
Input torque (at 1500 rpm):	max. 53,4 Nm (N) / max. 13,5 Nm (L)
Drive-through torque:	max. 540 Nm
Gear ratio:	9:1 (Normal) / 36:1 (Low)
Housing material:	GGG-50, corrosion-resistant
Worm shaft:	steel, case-hardened, ground
Weight of screw jack body:	39 kg
Gearbox / Screw lubrication:	synthetic gear oil / grease lubrication

### Ordering example: GSZ-100-SN-KGT 50x20, C = 127,3 kN



Because of the lack of friction, a holding brake is necessary: a motor brake or a spring pressure brake is required.

**Screw:** 1.1213 (Cf53), induction hardened and polished.

Screw jacks	KGT Screw ØxP	Dimensions mm											
		H	d	dk	D1	D2	L2	L3 <sup>1)</sup>	L4 <sup>1)</sup>	L5	L6	L7	M
GSZ-50	40x5	116	39	36,4	125	60	93	15	39	29	74	17	M30
	40x10	116	39	33,3	125	60	93	15	39	29	74	17	M30
	40x20	116	39	34,3	125	60	93	30	54	29	74	17	M30
	40x40	116	39	36,4	125	60	93	60	84	29	74	17	M30
GSZ-100	50x10	160	49	43,3	148	85	148	20	48	48	118	19	M36
	50x20	160	49	43,3	148	85	148	40	68	48	118	19	M36
	50x40	160	50	41,1	148	85	148	80	108	48	118	19	M36
GSZ-150	63x10	185	63	56,6	168	90	150	20	20	48	118	24	M32
	63x20	185	63	51,8	168	90	150	40	40	48	118	24	M32
	63x40	185	63	54,1	168	90	150	80	80	48	118	24	M32
	63x60 <sup>3)</sup>	185	63	54,1	168	90	150	120	120	48	118	24	M32

1) Depending on the control system and drive, the dimension L3 and L4 can be reduced at your own discretion.

An extension may be required if a bellows or spiral spring is fitted.

2) Dynamic load rating to DIN ISO 3408

3) Reduced play 0,02 mm available on request

KGT **R** **GSZ 2 to 25 kN**  
**KGT-R** | rotating screw

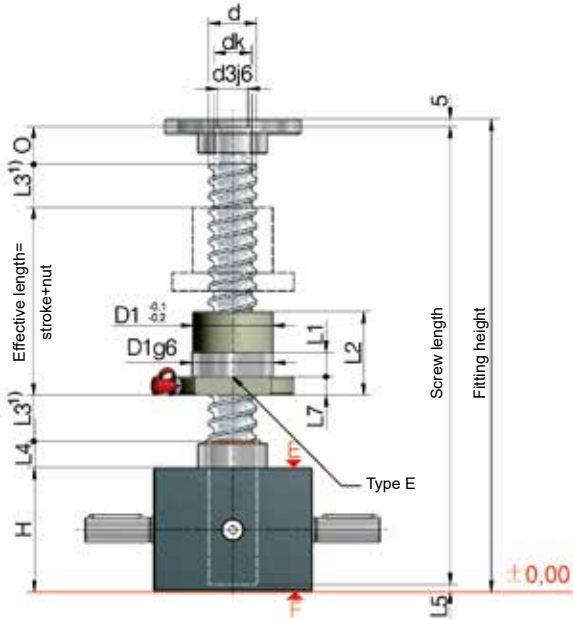

**Position of the flange nut:**  
 G = flange gearbox side (as shown)  
 S = flange screw side

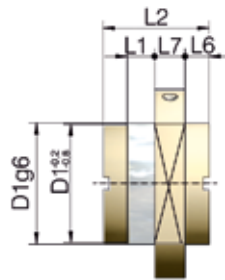

**Type S**

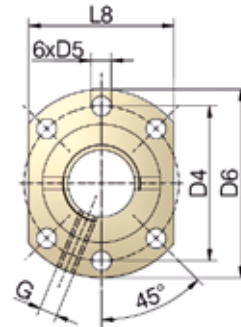

Hole pattern 1  
to DIN 69051

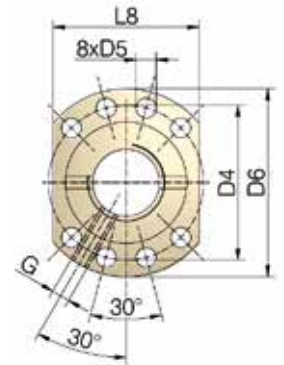

Hole pattern 2  
to DIN 69051

Screw jacks	KGT Screw ØxP	Stroke per drive revolution		KGT Load rating kN		Nut Type	Nut Hole pattern	Lubrication hole G	Axial play max <sup>2)</sup> mm
		RN	RL	dyn. C <sup>2)</sup>	stat. C <sub>0</sub> =C <sub>0a</sub>				
GSZ-2	16x5	1,25	0,31	10,1	12	E	1	M6	0,06
	16x10	2,5	0,63	11,1	12,9	E	1	M6	0,06
GSZ-5	16x5	1,25	0,31	10,1	12	E	1	M6	0,06
	16x10	2,5	0,63	11,1	12,9	E	1	M6	0,06
GSZ-10	25x5	1,25	0,31	13,7	21,5	E	1	M6	0,06
	25x10	2,5	0,63	25,2	45,4	E	1	M6	0,06
	25x25	6,25	1,56	20,7	37,3	E	1	M6	0,06
GSZ-25	25x50	12,5	3,14	19,2	37,3	E	1	M6	0,06
	32x5	0,83	0,21	24,8	49,7	E	1	M6	0,06
	32x10	1,67	0,42	30,8	45,6	E	1	M6	0,06
	32x20	3,33	0,83	32,9	47,1	E	1	M6	0,06
	32x40 <sup>3)</sup>	6,67	1,67	18,3	37,3	S	N <sup>4)</sup>	M6	0,06

# Technical data

## GSZ-2-R

max. compressive/tensile force, static:	2,5 kN (250 kg)
Input speed:	1500 rpm / max. 3000 rpm
Gearbox operating temperature:	max. 60°C, higher on request
Moment of inertia:	N: 0,047 kg cm <sup>2</sup> / L: 0,031 kg cm <sup>2</sup>
Input torque (at 1500 rpm):	max. 1,4 Nm (N) / max. 0,5 Nm (L)
Drive-through torque:	max. 9 Nm
Gear ratio:	4:1 (Normal) / 16:1 (Low)
Housing material:	aluminium, corrosion-resistant
Worm shaft:	steel, case-hardened, ground
Weight of screw jack body:	0,6 kg
Gearbox / Screw lubrication:	synthetic gear oil / grease lubrication

## GSZ-5-R

max. compressive/tensile force, static:	5 kN (500 kg)
Input speed:	1500 rpm / max. 3000 rpm
Gearbox operating temperature:	max. 60°C, higher on request
Moment of inertia:	N: 0,132 kg cm <sup>2</sup> / L: 0,226 kg cm <sup>2</sup>
Input torque (at 1500 rpm):	max. 4,7 Nm (N) / max. 1,5 Nm (L)
Drive-through torque:	max. 39 Nm
Gear ratio:	4:1 (Normal) / 16:1 (Low)
Housing material:	aluminium, corrosion-resistant
Worm shaft:	steel, case-hardened, ground
Weight of screw jack body:	1,2 kg
Gearbox / Screw lubrication:	synthetic gear oil / grease lubrication

## GSZ-10-R

max. compressive/tensile force, static:	10 kN (1 t)
Input speed:	1500 rpm / max. 3000 rpm
Gearbox operating temperature:	max. 60°C, higher on request
Moment of inertia:	N: 0,361 kg cm <sup>2</sup> / L: 0,226 kg cm <sup>2</sup>
Input torque (at 1500 rpm):	max. 13,5 Nm (N) / max. 7,5 Nm (L)
Drive-through torque:	max. 57 Nm
Gear ratio:	4:1 (Normal) / 16:1 (Low)
Housing material:	aluminium, corrosion-resistant
Worm shaft:	steel, case-hardened, ground
Weight of screw jack body:	2,1 kg
Gearbox / Screw lubrication:	synthetic gear oil / grease lubrication

## GSZ-25-R

max. compressive/tensile force, static:	25 kN (2,5 t)
Input speed:	1500 rpm / max. 3000 rpm
Gearbox operating temperature:	max. 60°C, higher on request
Moment of inertia:	N: 0,667 kg cm <sup>2</sup> / L: 0,443 kg cm <sup>2</sup>
Input torque (at 1500 rpm):	max. 18 Nm (N) / max. 10 Nm (L)
Drive-through torque:	max. 108 Nm
Gear ratio:	6:1 (Normal) / 24:1 (Low)
Housing material:	aluminium, corrosion-resistant
Worm shaft:	steel, case-hardened, ground
Weight of screw jack body:	3,8 kg
Gearbox / Screw lubrication:	synthetic gear oil / grease lubrication

Because of the lack of friction, a holding brake is necessary: a motor brake or a spring pressure brake is required.

**Screw:** 1.1213 (Cf 53), induction hardened and polished.

**Pitch accuracy:** 0,05 mm / 300 mm

### Note

An increased screw can also be used for the rotating version.  
(z.B.: ZE-10-RN with screw 32\*10)

Adapter for KGT:  
Dimension sheet on request



Screw jacks	KGT Screw	Dimensions mm																
		ØxP	d	dk	d3j6	O	H	D1	D4	D5	D6	L1	L2	L3 <sup>1)</sup>	L4	L5	L6	L7
GSZ-2	16x5	15,5	12,9	10	12	50	28	38	5,5	48	10	42	15	11	3		10	40
	16x10	15,4	13	10	12	50	28	38	5,5	48	10	55	25	11	3		10	40
GSZ-5	16x5	15,5	12,9	12	15	62	28	38	5,5	48	10	42	15	12	8		10	40
	16x10	15,4	13	12	15	62	28	38	5,5	48	10	55	25	12	8		10	40
GSZ-10	25x5	24,5	21,9	15	20	74	40	51	6,6	62	10	42	15	16	8		10	48
	25x10	24,5	21,9	15	20	74	40	51	6,6	62	16	55	25	16	8		10	48
	25x25	24,5	21,9	15	20	74	40	51	6,6	62	9	35	60	16	8	8	10	
	25x50	24,5	21,9	15	20	74	40	51	6,6	62	10	58	125	16	8	10	10	48
GSZ-25	32x5	31,5	28,9	20	25	82	50	65	9	80	10	55	15	17	5		12	62
	32x10	31,5	26,8	20	25	82	53 <sup>6)</sup>	65	9	80	16	69	20	17	5		12	62
	32x20	31,5	26,8	20	25	82	53 <sup>6)</sup>	65	9	80	16	80	35	17	5		12	62
	32x40 <sup>3)</sup>	31,5	28,9	20	25	82	53 <sup>6)</sup>	68 <sup>6)</sup>	7 <sup>6)</sup>	80	14	45	70	17	5	7,5	16	<sup>3)</sup>

1) Depending on the control system and drive, the dimension L3 and L4 can be reduced at your own discretion. An extension may be required if a bellows or spiral spring is fitted.

2) Dynamic load rating to DIN ISO 3408

3) Round flange

4) Non-preferred design

5) Reduced play 0,02 mm available on request

6) Not to DIN 69051



# GSZ 50 to 150 kN

## KGT-R | rotating screw

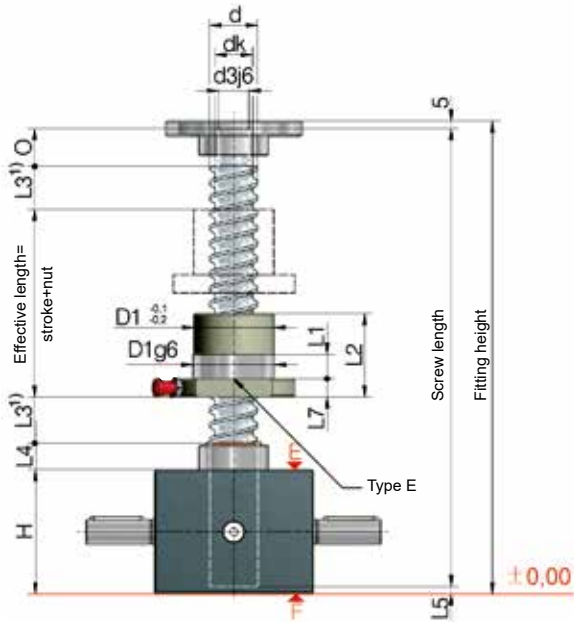

**Position of the flange nut:**  
 G = flange gearbox side (as shown)  
 S = flange screw side

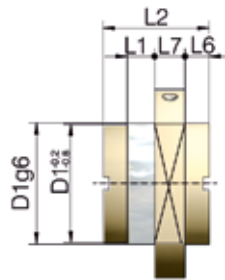

**Type S**

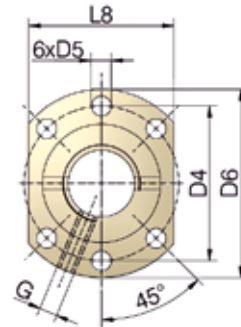

Hole pattern 1  
to DIN 69051

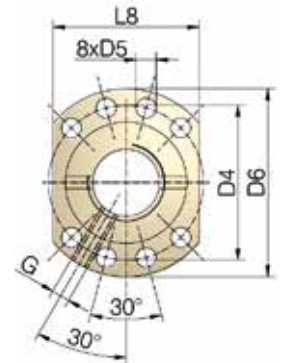

Hole pattern 2  
to DIN 69051

Screw jacks	KGT Screw ØxP	Stroke per drive revolution		KGT Load rating kN		Nut		Lubrication hole G	Axial play max <sup>9)</sup> mm
		RN	RL	dyn. C <sup>2)</sup>	stat. Co=C <sub>oa</sub>	Type	Hole pattern		
GSZ-50	40x5	0,71	0,18	27,5	63,6	E	1	M6	0,06
	40x10	1,43	0,36	46,1	71,3	E	1	M8x1	0,06
	40x20	2,86	0,72	44	80,4	E	1	M8x1	0,06
	40x40	5,71	1,43	35	101,9	E	1	M8x1	0,06
GSZ-100	50x10	1,11	0,28	122,4	248,6	E	1	M8x1	0,06
	50x20	2,22	0,56	127,3	270,3	E	1	M8x1	0,06
	50x40	4,44	1,11	84,7	143,1	E	1	M8x1	0,06
	50x50 <sup>4)</sup>	5,56	1,39	84,7	143,1	E	1	M8x1	0,03
GSZ-150	63x10	1,11	0,28	150,2	598,4	E	2	M8x1	0,03
	63x20	2,22	0,56	173,5 <sup>5)</sup>	346,2	E	2	M8x1	0,03
	63x40	4,44	1,11	96,6	205,1	E	2	M8x1	0,03
	63x60 <sup>3)</sup>	6,67	1,67	59,5	102,5	E	2	M8x1	0,03



# Technical data

## GSZ-50-R

max. compressive/tensile force, static:	50 kN (5 t)
Input speed:	1500 rpm / max. 1800 rpm
Gearbox operating temperature:	max. 60°C, higher on request
Moment of inertia:	N: 2,49 kg cm <sup>2</sup> / L: 1,73 kg cm <sup>2</sup>
Input torque (at 1500 rpm):	max. 31,5 Nm (N) / max. 10,4 Nm (L)
Drive-through torque:	max. 260 Nm
Gear ratio:	7:1 (Normal) / 28:1 (Low)
Housing material:	GGG-50, corrosion-resistant
Worm shaft:	steel, case-hardened, ground
Weight of screw jack body:	15 kg
Gearbox / Screw lubrication:	synthetic gear oil / grease lubrication

## GSZ-150-R

max. compressive/tensile force, static:	150 kN (15 t)
Input speed:	1500 rpm / max. 1800 rpm
Gearbox operating temperature:	max. 60°C, higher on request
Moment of inertia:	N: 7,92 kg cm <sup>2</sup> / L: 5,17 kg cm <sup>2</sup>
Input torque (at 1500 rpm):	max. 75,1 Nm (N) / max. 20,7 Nm (L)
Drive-through torque:	max. 540 Nm
Gear ratio:	9:1 (Normal) / 36:1 (Low)
Housing material:	GGG-50, corrosion-resistant
Worm shaft:	steel, case-hardened, ground
Weight of screw jack body:	42 kg
Gearbox / Screw lubrication:	synthetic gear oil / grease lubrication

## GSZ-100-R

max. compressive/tensile force, static:	100 kN (10 t)
Input speed:	1500 rpm / max. 1800 rpm
Gearbox operating temperature:	max. 60°C, higher on request
Moment of inertia:	N: 4,66 kg cm <sup>2</sup> / L: 3,38 kg cm <sup>2</sup>
Input torque (at 1500 rpm):	max. 53,4 Nm (N) / max. 13,5 Nm (L)
Drive-through torque:	max. 540 Nm
Gear ratio:	9:1 (Normal) / 36:1 (Low)
Housing material:	GGG-50, corrosion-resistant
Worm shaft:	steel, case-hardened, ground
Weight of screw jack body:	30 kg
Gearbox / Screw lubrication:	synthetic gear oil / grease lubrication

### Ordering example: GSZ-100-RN-KGT 50x20, C = 127,3 kN



Because of the lack of friction, a holding brake is necessary: a motor brake or a spring pressure brake is required.

**Screw:** 1.1213 (Cf 53), induction hardened and polished. **Pitch accuracy:** 0,05 mm / 300 mm

### Note

An increased screw can also be used for the rotating version.  
(z.B.: GSZ-10-RN with screw 32\*10)

Adapter for KGT:  
Dimension sheet on request



Screw jacks	KGT Screw	Dimensions mm																
		ØxP	d	dk	d3j6	O	H	D1	D4	D5	D6	L1	L2	L3 <sup>1)</sup>	L4	L5	L6	L7
GSZ-50	40x5	39	36,4	25	30	116	63	78	9	93	10	57	15	19	7		14	70
	40x10	39	33,3	25	30	116	63	78	9	93	16	71	15	19	7		14	70
	40x20	39	34,3	25	30	116	63	78	9	93	16	80	30	19	7		14	70
	40x40	39	36,4	25	30	116	63	78	9	93	16	85	60	19	7	7,5	14	<sup>3)</sup>
GSZ-100	50x10	49	43,3	40	45	160	75	93	11	110	16	107	20	30	8		16	85
	50x20	49	43,3	40	45	160	85 <sup>6)</sup>	103 <sup>6)</sup>	11	120 <sup>6)</sup>	16	125	40	30	8		16	95
	50x40	50	41,1	40	45	160	85 <sup>6)</sup>	103 <sup>6)</sup>	11	120 <sup>6)</sup>	16	125	80	30	8		16	95
	50x50 <sup>4)</sup>	50	41,1	40	45	160	85 <sup>6)</sup>	103 <sup>6)</sup>	11	120 <sup>6)</sup>	16	145	100	30	8		16	95
GSZ-150	63x10	63	56,6	45	55	185	90	108	11	125	16	135	20	32	7		18	95
	63x20	63	51,8	45	55	185	95	115	13,5	135	25	135	40	32	7		20	100
	63x40	63	54,1	45	55	185	95	115	13,5	135	25	126	80	32	7		20	100
	63x60 <sup>3)</sup>	63	54,1	45	55	185	95	115	13,5	135	25	126	120	32	7		20	100

1) Depending on the control system and drive, the dimension L3 and L4 can be reduced at your own discretion. An extension may be required if a bellows or spiral spring is fitted.

2) Dynamic load rating to DIN ISO 3408

3) Round flange

4) Non-preferred design

5) Reduced play 0,02 mm available on request

6) Not to DIN 69051



# CHAPTER 3

## Accessories

### S

#### S-Version add-on component

Fixing flange BF	
Forked end GK	
Rod end KGK	
Pivot bearing end SLK	100
Rotation protection VS	
Escape protection AS	
Protection tube SRO with lid	101
Limit switch ES	102
Pivoting support tube STRO	104

### R

#### R-Version adapter, nuts & bearing plate

Cardan adapter DMA for duplex nut DM	
Driving flange TRMFL for flange nut FM	106
Flange nut FM	
Duplex nut DM	
Safety nut SIFA-R	107
Self-aligning nut PM	
Greaseless nut FFDM	108
Opposed bearing plate GLP	109

### S + R

#### S + R-Version, bellows & spiral spring

Bellows FB, round, polygon, FBR, FBA, SK	110
Spiral spring SF structure, SF-5 to 150	112

#### S + R-Version, pivot

Pivot mounts LB, 5 - 350 kN	114
Pivot bearing plate 5 - 150	115

#### Other accessories

GSZ-Fixing strips	
Handwheel HR	
Protective cap	116

#### Motor flange and rotary voltage motors

Motor flange MF, 2 - 500	117
Rotary voltage motors (B14B + B14C)	122
Rotary voltage motors (B5 + B3)	124

# Accessories

## Add-on component | For the translating version



**Fixing flange BF**

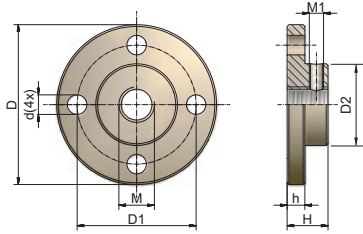

Code	D	D1	D2	M	d	h	H	M1	kg
GSZ-2-BF	50	40	26	M10	5,5	6	16	5	0,04
ZE-5-BF	65	48	29	M12	9	7	20	5	0,2
ZE-10-BF	80	60	38	M14	11	8	21	6	0,3
ZE-25-BF	90	67	46	M20	11	10	23	8	0,5
ZE-35/50-BF	110	85	60	M30	13	15	30	8	1,2
ZE-100-BF	150	117	85	M36	17	20	50	10	3,5
ZE-150-BF	170	130	90	M42x2	21	25	50	10	4,7
ZE-200-BF	200	155	110	M56x2	26	30	60	12	7,8
Z-250-BF	210	165	120	M56x2	26	30	60	12	9,5
Z-350-BF	260	205	145	M72x3	32	40	80	16	18,4
Z-500-BF	310	240	170	M100x3	38	40	120	16	30
Z-750-BF	340	265	200	M110x3	38	50	132	20	36

Material: steel, corrosion-resistant; aluminum, hard anodized (GSZ-2-BF) incl. set screw



**Forked end GK**

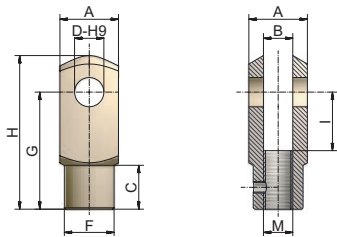

Code	A	B	C	D	M	F	G	H	I	kg
GSZ-2-GK	20	10	15	10	M10	18	40	52	20	0,1
ZE-5-GK	24	12	18	12	M12	20	48	62	24	0,2
ZE-10-GK	27	14	22	14	M14	24	56	72	28	0,2
ZE-25-GK	40	20	30	20	M20	34	80	105	40	0,7
ZE-35/50-GK	60	30	42	30	M30	52	120	160	60	2,5
ZE-100-GK	70	36	54	35	M36	60	144	188	72	3,7
ZE-150-GK	85	42	63	42	M42x2	70	168	232	84	5,3

Material: steel, galvanised (INOX on request) incl. bolt, splint and set screw



**Rod end KGK**

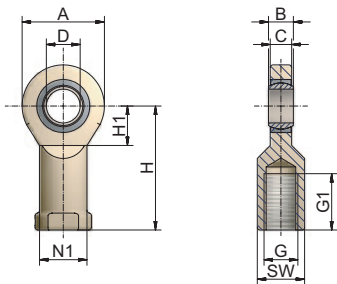

Code	A	B	C	D	G	G1	H	H1	SW	N1	kg
GSZ-2-KGK	31	14	12	10	M10	19	43	15	16	15	0,11
ZE-5-KGK	34	10	8,5	12	M12	23	50	17,5	18	17	0,1
ZE-10-KGK	40	12	10	15	M14	30	61	20	21	20	0,16
ZE-25-KGK	53	16	13	20	M20	40	77	27,5	30	27,5	0,32
ZE-35/50-KGK	73	22	19	30	M30	56	110	37	46	40	1,03
ZE-100-KGK	92	28	24	40	M36	65	142	46	60	52	2,1
ZE-150-KGK	112	35	31	50	M42x2	68	160	56	70	62	3,61
ZE-200-KGK	135	44	38	60	M56x2	70	175	73	75	70	5,6
Z-250-KGK	160	49	43	70	M56x2	80	200	80	85	80	8,45

Larger sizes on request

Material: steel/steel, galvanised; steel/PTFE for GSZ-2-KGK incl. set screw; (INOX on request)  
CAUTION: Use only with rotation protection! Larger sizes on request.



**Pivot bearing end SLK**

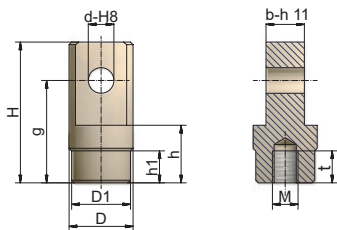

Code	H	D	D1	d	M	g	b	h	h1	t	kg
ZE-5-SLK	65	30	29	12	M12	48	18	25	20	22	0,3
ZE-10-SLK	80	40	39	14	M14	56	24	25	20	25	0,6
ZE-25-SLK	110	50	46	20	M20	80	30	45	25	25	1,2
ZE-35/50-SLK	130	65	60	30	M30	92	35	50	30	33	2,1
ZE-100-SLK	144	90	85	35	M36	108	40	65	40	55	4,4
ZE-150-SLK	210	100	90	50	M42x2	155	57	90	50	70	8
ZE-200-SLK	235	115	110	65	M56x2	165	70	85	45	63	12
Z-250-SLK	260	125	120	80	M56x2	180	80	85	40	63	16
Z-350-SLK	280	145	145	90	M72x3	195	100	105	-	83	24
Z-500-SLK	340	170	170	100	M100x3	245	120	150	-	120	38
Z-750-SLK	380	225	200	120	M110x3	270	130	155	80	133	68,5

Material: steel, corrosion resistant incl. set screw

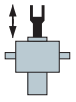

# S Accessories

**Add-on component** | For the translating version

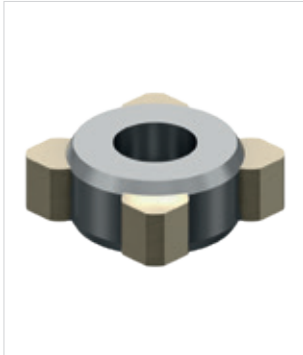

**Rotation protection VS**

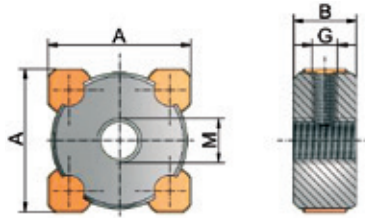

Rotation protection is required if the screw is not fixed to the load so that it cannot rotate, or is installed in combination with limit switches or the rod end KGK.

Code	A	B	G	M	kg
GSZ-2-VS*	31x21	15	Ø3	M10	0,01
ZE-5-VS*	31	15	M6	M12	0,1
ZE-10-VS	46	20	M8	M14	0,23
ZE-25-VS	46	20	M8	M20	0,23
ZE-35-VS	56	30	M8	M24	0,65
ZE-50-VS	84	30	M10	M30	1,27
ZE-100-VS	84	30	M10	M36	1,2
ZE-150-VS	114	30	M10	M48x2	2,15
ZE-200-VS	114	30	M10	M56x2	2,15
Z-250-VS	114	30	M10	M64x3	2,15
Z-350-VS	152	35	M16	M72x3	4,6
Z-500-VS	170	40	M16	M85x3	6,6
Z-750-VS	190	40	M16	M100x3	8
Z-1000-VS	208	40	M16	M100x3	10,2

Material: steel, bronze - \*For ZE-5, the VS is made of solid bronze. GSZ-2 POM incl. set screw.



**Escape protection AS**

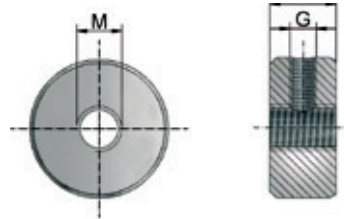

Escape protection prevents the screw being wound out of the gearbox. It is particularly recommended for ball screws. Do not rely on it as an operating travel stop.

Code	A	G	M	kg
GSZ-2-AS	15	M5	M10	0,01
ZE-5-AS	15	M6	M12	0,05
ZE-10-AS	20	M8	M14	0,16
ZE-25-AS	20	M8	M20	0,14
ZE-35-AS	30	M8	M24	0,4
ZE-50-AS	30	M10	M30	0,8
ZE-100-AS	30	M10	M36	0,74
ZE-150-AS	30	M12	M48x2	1,48
ZE-200-AS	30	M10	M56x2	1,49
Z-250-AS	30	M12	M64x3	1,17
Z-350-AS	35	M16	M72x3	2,87
Z-500-AS	40	M16	M85x3	3,86
Z-750-AS	40	M16	M100x3	6
Z-1000-AS	40	M16	M100x3	9,6

Material: steel, Incl. set screw.

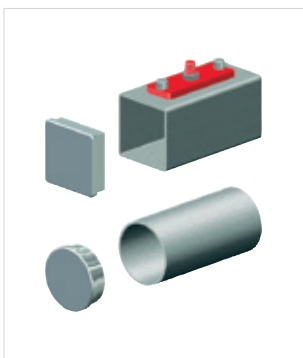

**Protective tube SRO with lid**

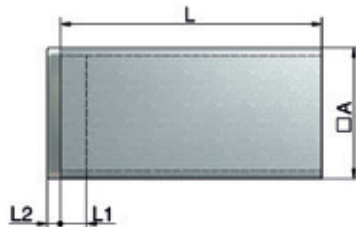

Code	A	L1	L2	kg/m
GSZ-2-SRO	35x25	14	5	0,6
ZE-5-SRO	35	10	5	2,1
ZE-10-SRO	50	10	5	3,1
ZE-25-SRO	50	10	5	3,1
ZE-35-SRO	60	10	5	3,8
ZE-50-SRO	90	10	5	8,2
ZE-100-SRO	90	10	5	8,2
ZE-150-SRO	120	10	5	11,5
ZE-200-SRO	120	10	5	11,5
Z-250-SRO	Ø 125 / □ 120	10	5	7,6 / 11,5
Z-350-SRO	Ø 150 / □ 160	15	5	19,0 / 19,3
Z-500-SRO	Ø 180 / □ 180	15	5	22,0 / 27,0
Z-750-SRO	Ø 210 / □ 200	15	5	26,0 / 30,0
Z-1000-SRO	Ø 260 / □ 220	15	5	32,0 / 39,0

Material: steel, powder coated/painted. Aluminum, black anodized (GSZ-2-SRO)

Lid: aluminum, corrosion resistant; PE, black (GSZ-2)

Incl. set screw.

# Limit switch set ESSET for the translating version

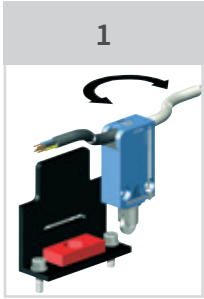
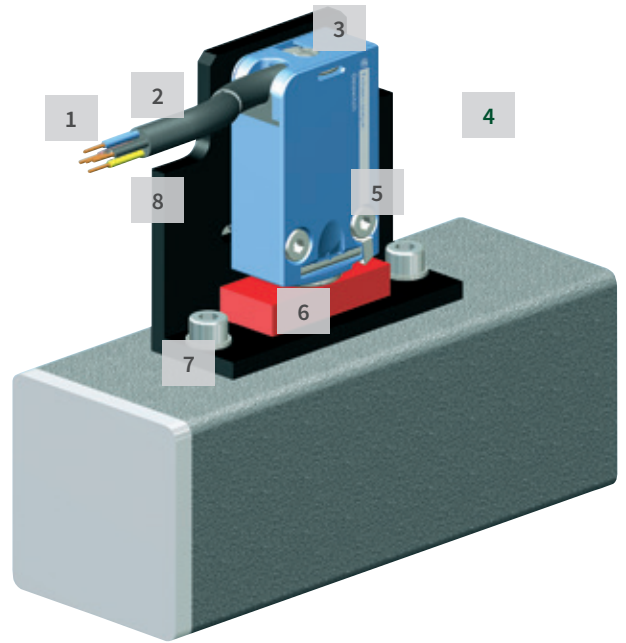

1  
Cable outlet turnable 180°



2  
Cabel length  
5m standard  
(2 m, 10 m)



3  
Integrated plug,  
for fast and comfortable  
revisions

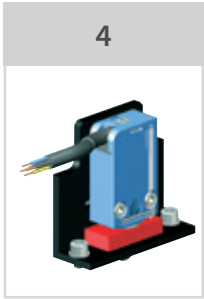

4  
One size  
fits all

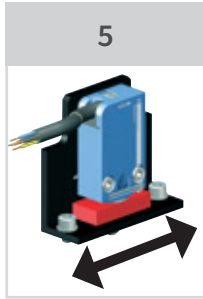

5  
Fine adjustment  
+/- 5 mm possible



6  
Enclosed fitting,  
resistant to dirt  
penetration

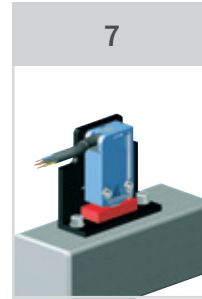

7  
Assembled and preset  
delivery

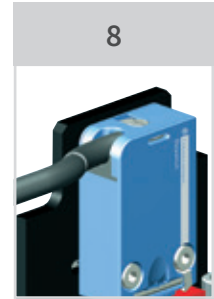

8  
Massive mounting,  
protection against  
damage

## Technical data

Type:	Mechanical limit switch with positively-actuated NC relay
Material:	Metal housing and roller plunger
Mode of operation:	1Ö + 1S, snap action contacts
Protection class:	IP67
Temperature range:	-40°C to +70°C
Cabel standard-material:	PVC black Ø 7,3 mm, 5 x 0,75 mm <sup>2</sup>
Cabel standard-temperature:	-25°C to +70°C
Cabel special-temperature:	-40°C to +105°C (only available on request)
Electrical duty:	max. 240V AC / 1,5A max. 250V DC / 0,1A
Electrical service life:	5 million switching operations at 24V DC/3W 1 million switching operations at 230V AC/0,5A
Weight:	Limit switch set: 0,2 kg; cabel (5m): 0,45 kg

NC	BK BK-WH	black black-white	black black-white
NO	BU BN	blue brown	blue brown
Protective earth conductor	GN-YE	green-yellow	green-yellow

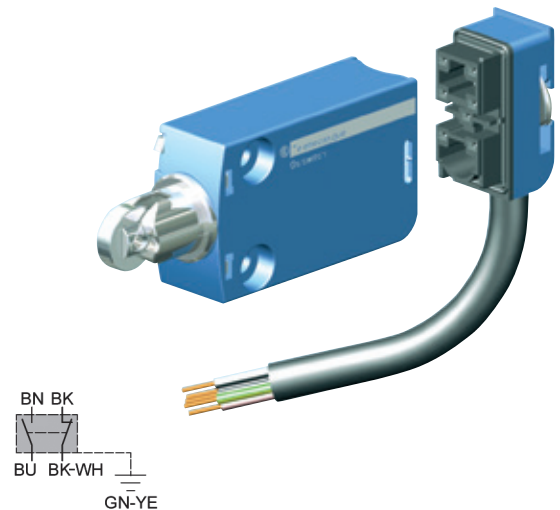

Ordering example for an single switch: **ZE-25-ES-5**

Gearbox size \_\_\_\_\_  
 Limit switch \_\_\_\_\_  
 Cable length \_\_\_\_\_  
 2m, 5m (standard) or 10m, 0 = without cable

# Limit switch ES - Dimensions

Positions | for the translating version

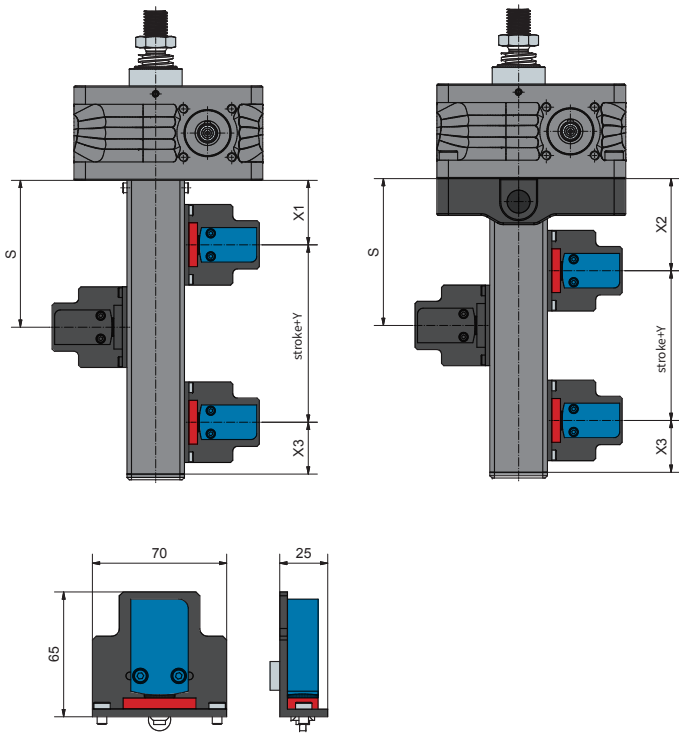
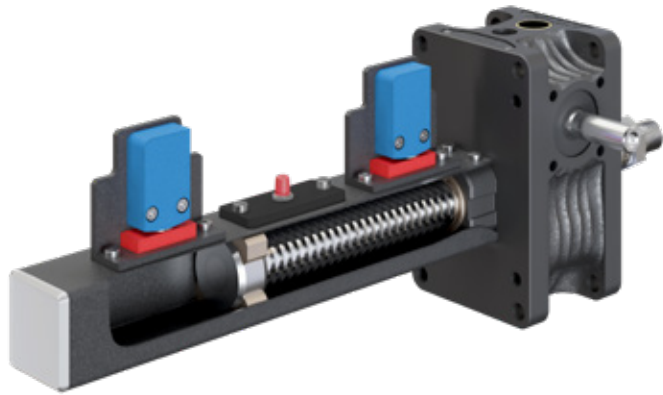

Size	Screw	X1	X2	X3	Y
GSZ-2	Tr16x4	48	70	48	21
ZE-5	Tr18x4	49	70	45	25
	KGT16x05, x10	49	70	45	25
ZE-10	Tr20x4	52	72	45	24
	KGT25x05, x10	52	72	45	24
ZE-10	KGT25x25	77	77	68	24
	KGT25x50	142	142	133	24
ZE-25	Tr30x6	56	80	45	24
	KGT32x05, x10, x20	56	80	45	24
ZE-25	KGT32x40	91	91	78	24
	Tr40x7	64	90	45	34
ZE-35	Tr40x7	65	90	45	34
	Tr40x7	65	90	45	34
ZE-50	KGT40x5, x10, x20	65	90	45	34
	KGT40x40	90	90	68	34
ZE-50/Tr50	Tr50x8	65	90	45	34
ZE-100	Tr55x9	65	110	45	34
	KGT50x10	65	110	45	34
ZE-100	KGT50x20	70	110	48	34
	KGT50x40	110	110	88	34
ZE-150	Tr60x9	70	120	45	34
	KGT63x10	70	120	45	34
ZE-150	KGT63x20	75	120	48	34
	KGT63x40	115	120	88	34
ZE-150	KGT63x60	155	155	128	34
	Tr70x12	70	-	45	34
ZE-200	KGT80x10	70	-	45	34
	KGT80x20	75	-	48	34
ZE-200	KGT80x40	115	-	88	34
	KGT80x60	155	-	128	34
Z-250	Tr80x16	75	-	45	30
	KGT80x10	75	-	45	30
Z-250	KGT80x20	82	-	50	30
	KGT80x40	122	-	90	30
Z-250	KGT80x60	162	-	130	30
	Tr100x16	85	-	50	31
Z-350	KGT100x20	94	-	57	31
	KGT100x40	134	-	97	31
Z-350	KGT100x60	174	-	137	31
	KGT100x80	214	-	177	31
Z-500	Tr120x16	102	-	55	40
	KGT125x25	112	-	65	40
Z-500	KGT125x40	142	-	95	40
	KGT125x60	182	-	135	40
Z-500	KGT125x80	222	-	175	40
	Tr140x20	110	-	55	40
Z-750	KGT140x25	112	-	65	40
	KGT140x40	142	-	95	40
Z-750	KGT140x60	182	-	135	40
	KGT140x80	222	-	175	40
Z-1000	Tr160x20	110	-	55	40
	KGT160x25	112	-	65	40
Z-1000	KGT160x40	142	-	95	40
	KGT160x60	182	-	135	40
Z-1000	KGT160x80	222	-	175	40

### Limit switch positions

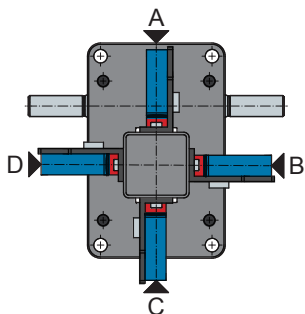

The limit switch can be mounted on any potential position/side of the protective tube

# S Pivoting support tube STRO

Maximum stroke 500 mm, above on request

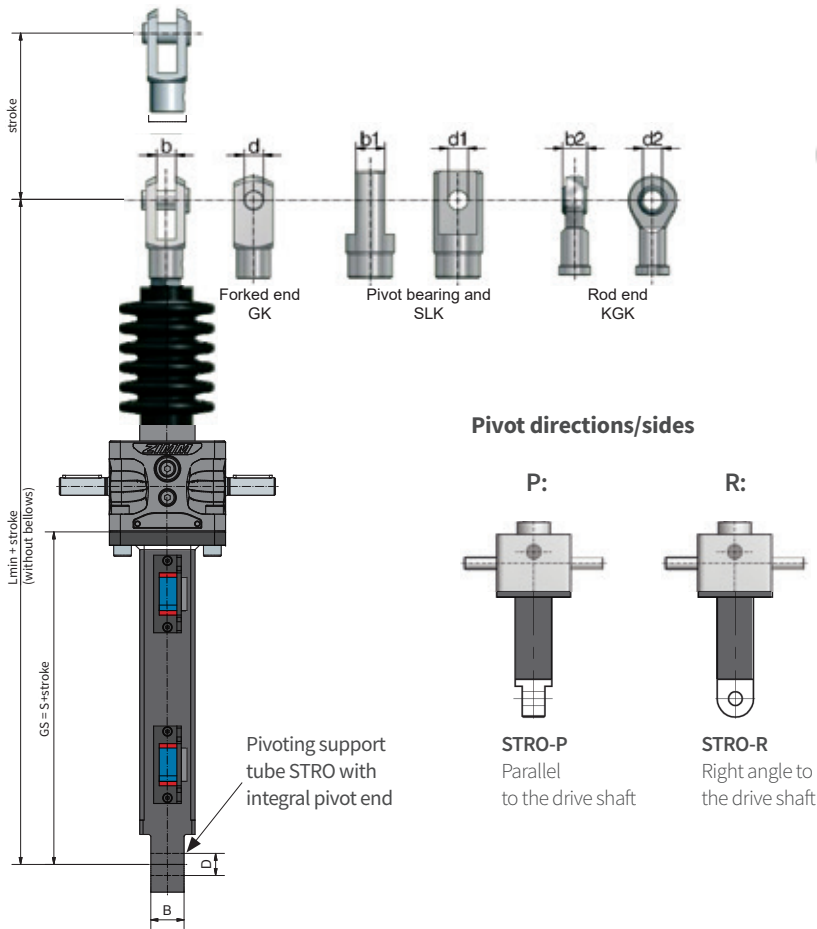

**Note**  
When using the pivoting support tube, take into consideration the torques arising due to the weight of the motor etc. - support is necessary

Size	Options	S	L min. GK	L min. SLK	L min. KGK	d	b	d1	b1	d2	b2	D	B
ZE-5	Standard	82	224	224	226	12	12	12	18	12	10	12	20
	with AS/VS	97	239	239	241	12	12	12	18	12	10	12	20
	with ES	155	297	297	299	12	12	12	18	12	10	12	20
ZE-10	Standard	94	262	262	267	14	14	14	24	15	12	20	30
	with AS/VS	114	282	282	287	14	14	14	24	15	12	20	30
	with ES	166	334	334	339	14	14	14	24	15	12	20	30
ZE-25	Standard	98	303	303	300	20	20	20	30	20	16	20	30
	with AS/VS	118	323	323	320	20	20	20	30	20	16	20	30
	with ES	170	375	375	372	20	20	20	30	20	16	20	30
ZE-35	Standard	117	390	362	380	30	30	30	35	30	22	30	35
	with AS/VS	147	420	392	410	30	30	30	35	30	22	30	35
	with ES	203	476	448	466	30	30	30	35	30	22	30	35
ZE-50	Standard	137	426	398	416	30	30	30	35	30	22	40	50
	with AS/VS	167	456	428	446	30	30	30	35	30	22	40	50
	with ES	219	508	480	498	30	30	30	35	30	22	40	50
ZE-50/Tr50	Standard	137	454	418	42	35	36	35	40	40	28	40	50
	with AS/VS	167	484	448	482	35	36	35	40	40	28	40	50
	with ES	219	536	500	534	35	36	35	40	40	28	40	50
ZE-100	Standard	157	539	503	537	35	36	35	40	40	28	40	50
	with AS/VS	187	569	533	567	35	36	35	40	40	28	40	50
	with ES	219	601	565	599	35	36	35	40	40	28	40	50

**Ordering Example:** **ZE-25-STRO-P, GS=150mm**  
ZE or GSZ

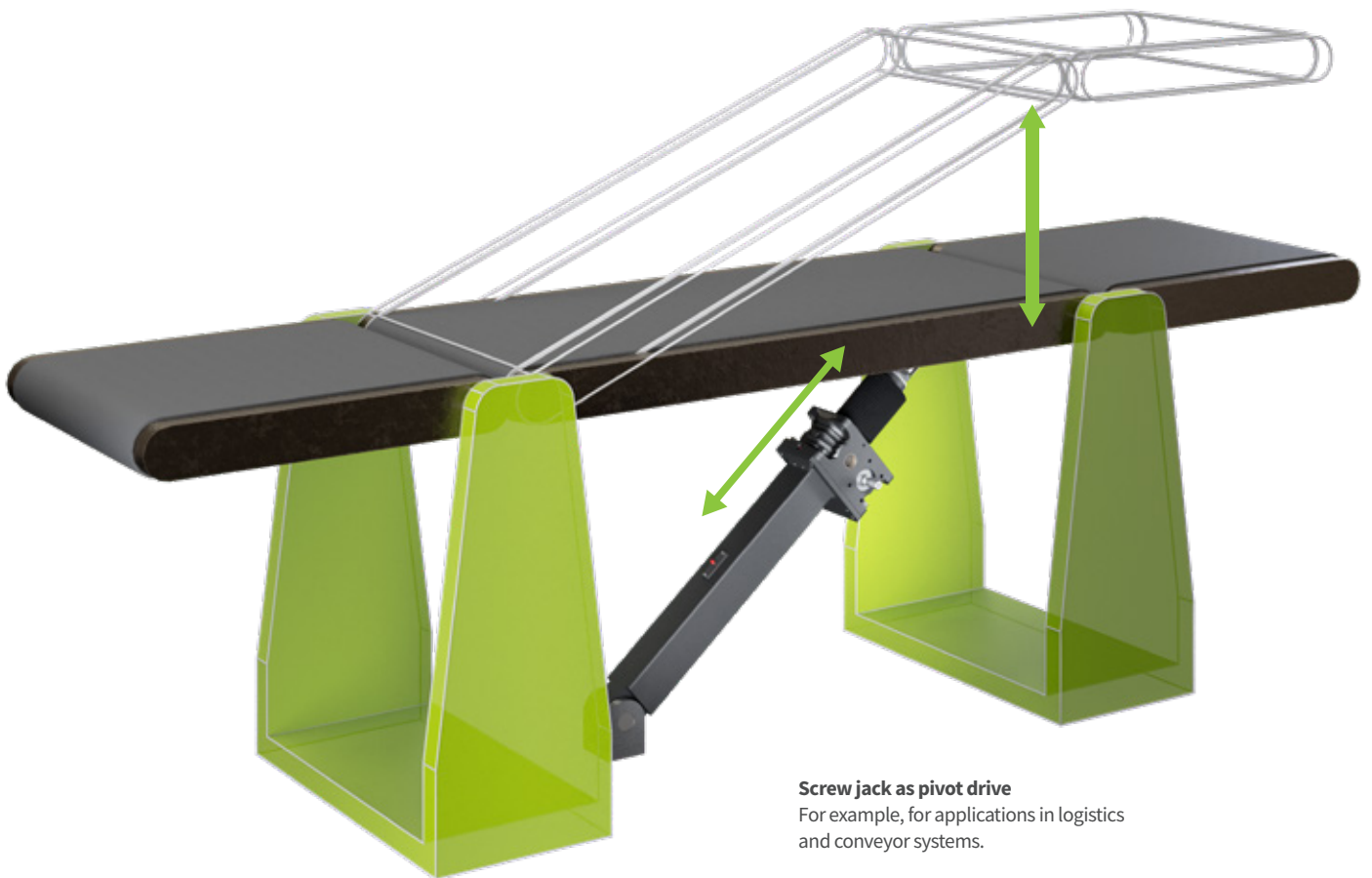

# PRACTICAL PIVOT BEARING - SUPPORT TUBE APPLICATION

**Screw jack as pivot drive**

For example, for applications in logistics and conveyor systems.

**R Accessories**  
Nuts | rotating version

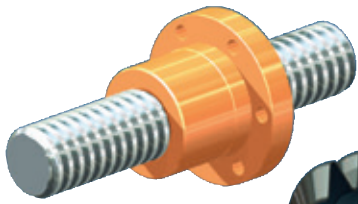

**Flange nut FM**  
Standard nut for simple applications

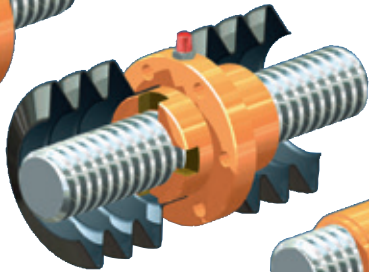

**Duplex nut DM**  
- Bellows can be attached both sides  
- Uniform Ø on gearbox neck, nut and opposed bearing plate  
- Grease nipple or connection to central lubrication or lubricator

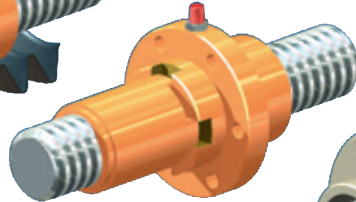

**Safety nut SIFA**  
In combination with duplex nut or self-aligning nut

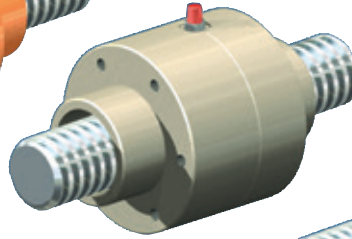

**Self-aligning nut PM**  
- Angular compensation up to max. 3°  
- Bellows can be attached both sides  
- Uniform Ø on gearbox neck, nut and opposed bearing plate  
- Grease nipple or connection to central lubrication or lubricator

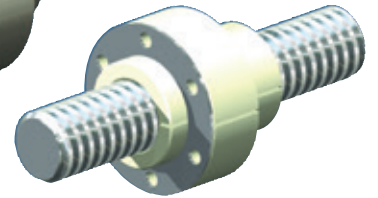

**Greaseless nut FFDM**  
- Specially suitable for dry running (such as textiles, foodstuffs, chemicals,...)  
- Bellows can be attached both sides  
- Reinforced with a stainless steel washer

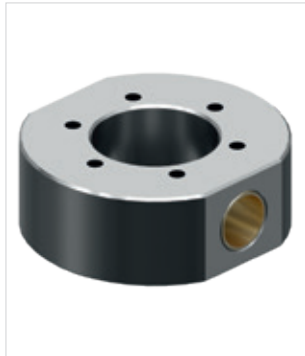

**Cardan adapters DMA for duplex nut DM**

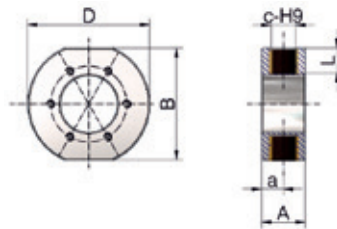

Code	B	D	c-H9	L	A	a	kg
ZE-5-DMA	72	78	16	15	30	15	1
ZE-10-DMA	72	78	16	15	30	15	0,9
ZE-25-DMA	90	98	20	20	36	18	1,4
ZE-35-DMA	100	116	28	15	46	23	2,3
ZE-50-DMA	100	116	30	15	46	23	2,3
ZE-100-DMA	140	156	40	25	60	30	4,8
ZE-150-DMA	145	160	50	25	76	38	6,8
ZE-200-DMA	175	192	50	25	80	40	10,3
Z-250-DMA	185	206	60	30	90	45	12,7

Material: steel, corrosion-resistant; pivot bearing: Bronze, PTFE coated



**Main direction of loading**

Select the main direction of loading so that tensile loads on the nut are avoided

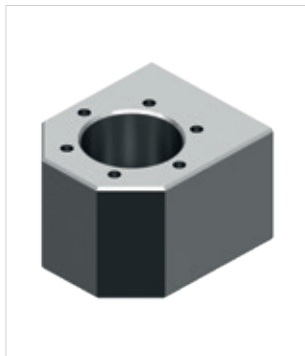

**Driving flange TRMFL for flange nut FM**

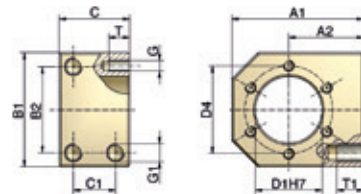

Code	für FM	A1	A2max <sup>1)</sup>	A2min <sup>1)</sup>	B1	B2	C	C1	G1xT	D1	D4	GxT	kg
TRMFL-18x4 <sup>2)</sup>	Tr18x4	60	35	25	50	34	40	24	M8x15	28	38	M5x10	0,7
TRMFL-20x4	Tr20x4	68	37,5	29	58	39	40	24	M8x15	32	45	M6x12	0,9
TRMFL-30x6	Tr30x6	75	42,5	32,5	65	49	40	24	M10x15	38	50	M6x12	1,1
TRMFL-40x7	Tr40x7	120	70	50	100	76	65	41	M14x25	63	78	M8x14	4,5

Material: steel, corrosion-resistant

1) Supplied ex-works with size A2max! Can be machined by the customer to A2min.

2) Also suitable for GSZ-2-FM (Tr 16x4)

# Accessories

## Nuts | rotating version



Flange nut FM

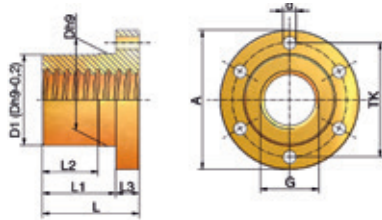

Code	G	D1*Dh9	TK	A	d (6x)	L	L1	L2	L3	kg
GSZ-2-FM	Tr16x4	28	38	48	6	35	23	15	12	0,2
ZE-5-FM	Tr18x4	28	38	48	6	35	23	15	12	0,2
ZE-10-FM	Tr20x4	32	45	55	7	44	32	24	12	0,3
ZE-25-FM	Tr30x6	38	50	62	7	46	32	24	14	0,4
ZE-35/50-FM	Tr40x7	63	78	95	9	66	50	38	16	1,7
ZE-100-FM	Tr55x9	85	108	130	11	90	70	54	20	4
ZE-150-FM	Tr60x9	90	116	140	13	100	75	54	25	5,5
ZE-200-FM	Tr70x12	110	143	175	17	120	90	60	30	10,2
Z-250-FM	Tr80x16	120	153	185	17	130	95	65	35	14,3
Z-350-FM	Tr100x16	145	189	230	23	150	115	75	40	20,4
Z-500-FM	Tr120x16	170	214	255	23	170	130	80	50	28,9
Z-750-FM	Tr140x20	200	252	289	23	210	160	100	60	48
Z-1000-FM	Tr160x20	250	300	350	26	260	200	120	70	96,2

Material: 2.1090.01 (RG7-bronze)

Quality: 7H DIN 103. Right-handed (left-handed, double pitch on request)

\*D1=Dh9-0,2 mm



Duplex nut DM

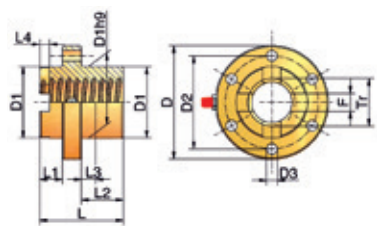

Code	Tr	D	D1	D2	D3	L	L1	L2	L3	L4	F	kg
GSZ-2-DM	Tr16x4	49	26	40*	5,5*	45	13	20	8	6	6	0,3
ZE-5-DM	Tr18x4	52	29	40	6	45	13	20	8	6	6	0,3
ZE-10-DM	Tr20x4	68	39	54	7	45	13	20	8	6	8	0,6
ZE-25-DM	Tr30x6	79	46	61	7	50	13	23	8	7	12	0,8
ZE-35/50-DM	Tr40x7	95	60	78	9	70	18	36	12	8,5	15	1,5
ZE-100-DM	Tr55x9	130	85	108	11	90	18	54	18	10	20	4,1
ZE-150-DM	Tr60x9	140	90	116	13	115	20	75	20	10	20	5,3
ZE-200-DM	Tr70x12	175	110	143	17	130	25	75	30	14	25	10,3
Z-250-DM	Tr80x16	185	120	153	17	140	25	85	30	14	25	12,2
Z-350-DM	Tr100x16	230	145	189	23	160	25	100	35	14	24	21,6
Z-500-DM	Tr120x16	255	170	214	23	180	30	110	40	14	30	30,5
Z-750-DM	Tr140x20	289	200	252	23	220	30	140	50	18	30	58,3
Z-1000-DM	Tr160x20	350	250	300	26	320	50	210	70	18	35	155

Material: 2.1090.01 (RG7-bronze); Quality: 7H DIN 103 right-handed (left-handed, double pitch on request); Threaded grease nipple, up to ZE-50 G1/8", from ZE-100 G1/4"

\*only 4 drill holes Ø 5,5mm



Safety nut SIFA-R

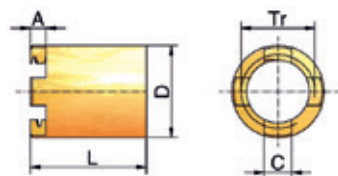

Code	Tr	A	C	D	L	kg
GSZ-2-SIFA-R	Tr16x4	6	6	22	28	0,05
ZE-5-SIFA-R	Tr18x4	6	6	24	28	0,1
ZE-10-SIFA-R	Tr20x4	6	8	28	42	0,1
ZE-25-SIFA-R	Tr30x6	7	12	38	47,5	0,2
ZE-35/50-SIFA-R	Tr40x7	8,5	15	50	67	0,5
ZE-100-SIFA-R	Tr55x9	10	20	65	87	1,1
ZE-150-SIFA-R	Tr60x9	10	20	70	100	1,2
ZE-200-SIFA-R	Tr70x12	14	25	95	110	3,8
Z-250-SIFA-R	Tr80x16	14	25	100	115	3,3
Z-350-SIFA-R	Tr100x16	14	24	120	115	4,07
Z-500-SIFA-R	Tr120x16	14	30	135	128	6,02
Z-750-SIFA-R	Tr140x20	18	30	170	151	13,8
Z-1000-SIFA-R	Tr160x20	18	35	190	186	19,8

Material: RG7

**R Accessories**  
Nut | rotating version



**Self-aligning nut PM**

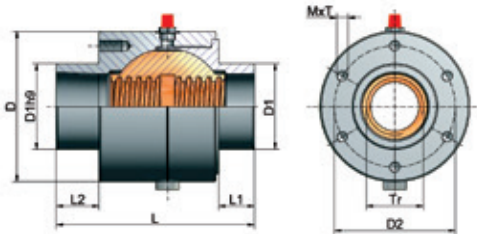

**Technical data**

Trapezoidal screw: DIN 103, quality 7H, right-handed  
 Screwed grease nipple: Thread 1/8" / 1/4" ab Tr 40x7  
 Material:  
     Housing: GG25 (Grey cast iron)  
     Spherical nut: Rg7 (Bronze)  
 Safety nut SIFA: is available for the self-aligning nut on request

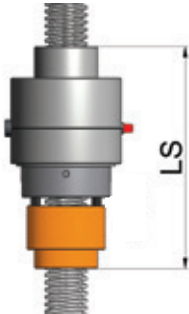

Code	Thread Tr dxP	D	D1	D2	M x T	L	L1	L2	LS*	kg
ZE-5-PM	Tr18x4	52	29	40	M5x12	78	13	21	123	0,7
ZE-10-PM	Tr20x4	74	39	60	M6x12	83	13	24	128	1,5
ZE-25-PM	Tr30x6	88	46	70	M6x12	95	13	27	158	2,4
ZE-35/50-PM	Tr40x7	105	60	85	M8x16	129	15	30	212	5,1
ZE-100-PM	Tr55x9	148	85	120	M10x20	190	15	45	298	15,1
ZE-150-PM	Tr60x9	165	90	125	M12x24	210	15	45	330	21,9
Z-250-PM	Tr80x16	225	120	170	M16x32	224	20	40	369	47
Z-350-PM	Tr100x16	280	145	215	M20x40	275	20	40	455	94

\*Overall length PM incl. safety nut SIFA

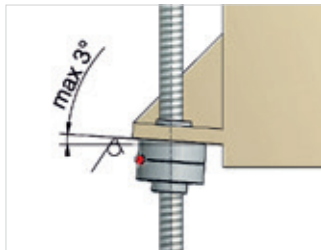

**Application**

(Welded) fabrications often exhibit angular errors, which lead to rapid wear of the trapezoidal screw nuts. The self-aligning nut PM can compensate small angular errors on the attachment face up to maximum +/-3°. A large grease reservoir increases the maintenance intervals and extends the service life

**CAUTION**

Self-aligning nuts cannot compensate parallelism errors between screws or between screws and guides. Take care to ensure precise alignment. The attachment faces for the gearboxes must therefore be exactly at right angles to the guides.



**Greaseless nut FFDM**

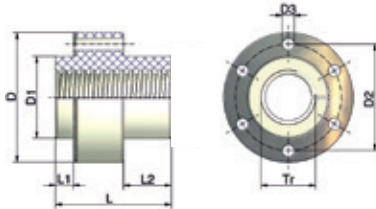

Code	Tr	D	D1 <sup>2)</sup>	D2	D3	L	L1	L2	kN max. load	kg
ZE-5-FFDM	Tr18x4	52	29	40	6	53	11	20	1	0,1
ZE-10-FFDM	Tr20x4	68	39	54	7	53	11	20	2	0,1
ZE-25-FFDM	Tr30x6	79	46	61	7	59	11	23	5	0,2
ZE-35/50-FFDM	Tr40x7	95	60	78	9	85	13	35	7	0,4

Nut material: Plastic, high-performance ploymer

Steel ring material: stainless steel

Quality: 7H DIN 103, right-handed

1) As approximate value, depending on the stroke speed and ambient temperature

2) Connection bore for D1 +0,2 mm for thermal expansion



## Accessories

### Opposed bearing plate | rotating version



Opposed bearing plate GLP

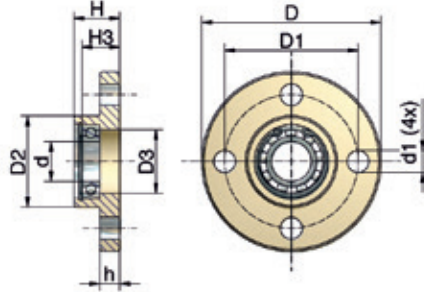

The opposed bearing plate increases the smoothness of operation and the resistance of the screw to buckling. Allow 5 mm at the end of the screw for length compensation. The ball bearing is already mounted on delivery.

Code	ØD	ØD1	ØD2	ØD3	Ød	Ød1	h	H	H3	Bearing	Si-Ring	kg
GSZ-2-GLP	50	40	26	19	10	5,5	6	16	12	61900.2RS	J 22	0,05
ZE-5-GLP	65	48	29	20	12	9	7	20	13	61901.2RS	J 24	0,2
ZE-10-GLP	80	60	39	28	15	11	8	21	17	6002.2RS	J 32	0,5
ZE-25-GLP	90	67	46	32	20	11	10	23	19	61904.2RS	J 37	0,5
ZE-35/50-GLP	110	85	60	42	25	13	15	30	22	6005.2RS	J 47	1,1
ZE-100-GLP	150	117	85	60	40	17	20	50	35	6008.2RS	J 68	2,9
ZE-150-GLP	170	130	90	68	45	21	25	50	31	6009.2RS	J 75	4
ZE-200-GLP	200	155	110	83	50	26	30	60	50	2x6210.2RS	J 90	7,2
Z-250-GLP	210	165	120	85	60	26	30	60	50	2x6012.2RS	J 95	6,9
Z-350-GLP	265	205	145	110	80	27	32	65	54	2x6016.2RS	J125	11,5
Z-500-GLP	310	240	170	130	95	38	40	100	60	2x6019.2RS	J145	24
Z-750-GLP	350	280	200	168	100	6x32	40	100	83	2x6020.2RS	J180	32

Material: steel, corrosion-resistant; up to ZE-200 stainless bearings

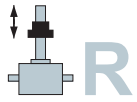
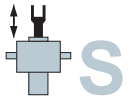

# Accessories

**Bellow FB** | Add-on component for translating and rotating version

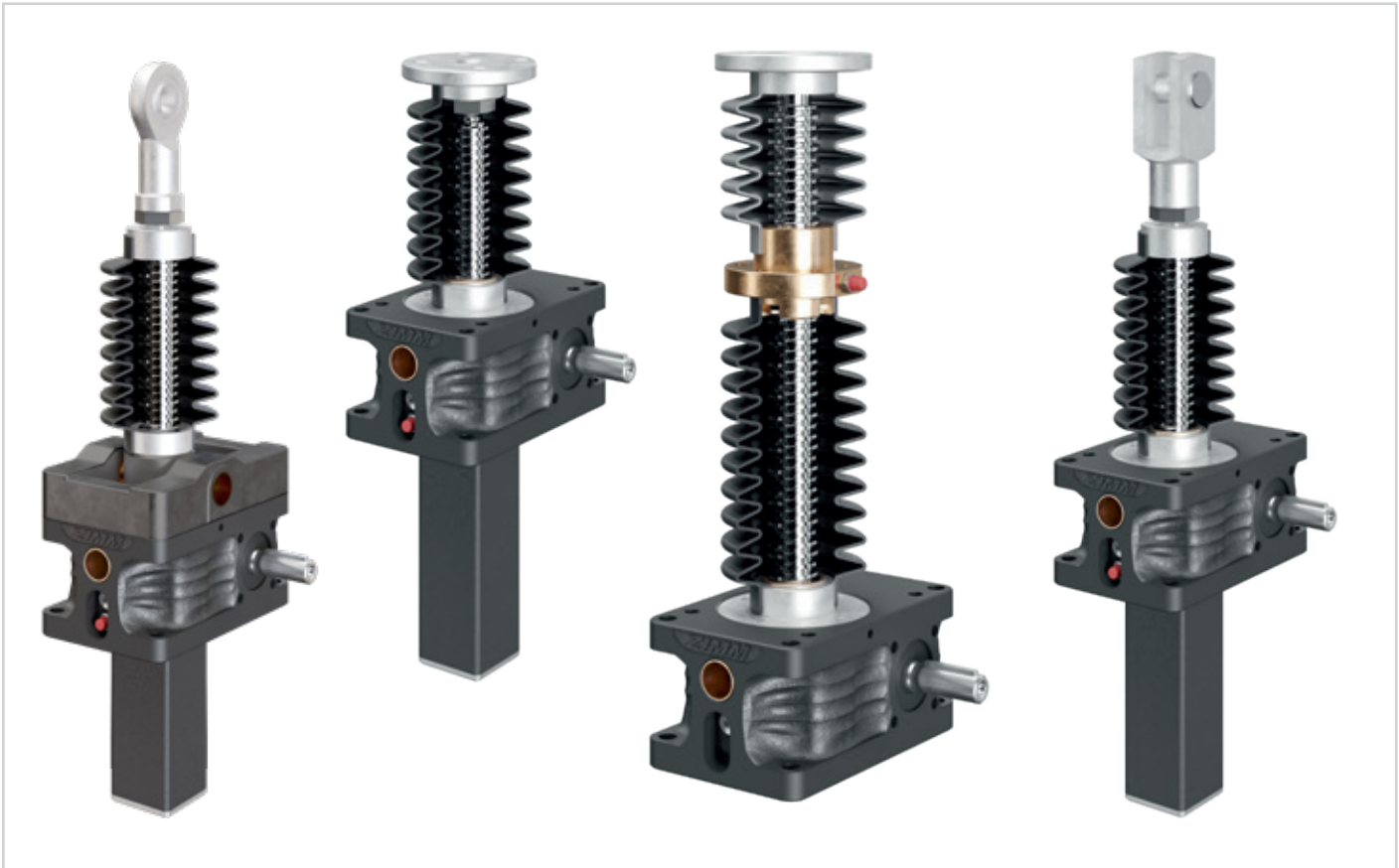

**The bellows protect the screw and lubricant against dirt and moisture**

For optimum conditions use in conjunction with a bellows.

**PLEASE NOTE:**

The bellows must not be compressed to less than the ZD dimension nor extended beyond the AZ dimension. If the stroke is longer than 1000 mm, fit a bellows with an extension block. Take into consideration that when the bellows are fitted horizontally they must not touch the screw.

**Risk of destruction!**

This is prevented by using bellows with bushings. A special installation to protect the spindle and bellows is required from: Concrete dust, grinding dust from angle grinders, welding spatter, etc. protect the bellows also from direct sunlight. The maximum operating cycle of the lifting gear can be reduced by the heat-insulating effect of the bellows.



**Bellow FB, round**

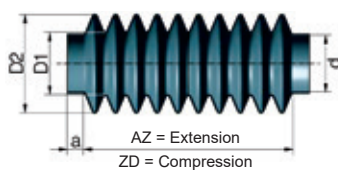

Code	a	d	ZD	AZ	Hub	D1	D2	kg
GSZ-2-FB-182	11	26	38	220	182	26	55	0,08
GSZ-2-FB-364	11	26	98	462	364	26	55	0,16
ZE-5-FB-265	12	29	35	300	265	40	76	0,2
ZE-10-FB-340	10	39	80	420	340	40	80	0,2
ZE-25-FB-300	15	50	70	370	300	50	83	0,3
ZE-35/50-FB-390	18	60	85	475	390	66	102	0,4
ZE-100-FB-285	15	85	75	360	285	85	118	0,3
ZE-150-FB-350	20	90	50	400	350	92	141	0,4
ZE-200-FB-390	15	110	90	480	390	110	160	0,8
Z-250-FB-390	15	120	90	480	390	125	166	1,1
Z-350-FB-600	15	145	100	700	600	172	236	2,4

Material: Thermoplast 99, PVC, operating temperature -20°C to +70°C (max. +85°C), cold fracture temperature -32°C, incl. 2 galvanised hose clips..

CAUTION: For screw extensions, see Sections 2+3

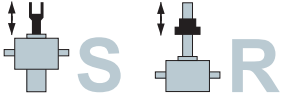

## Accessories

**Bellow FB** | Add-on component for translating and roating version



**Bellows -FB, polygonal**

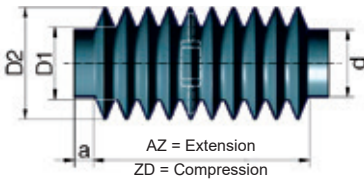

Material: Polyurethane-coated polyester fabric type, temperature stability  $-18^{\circ}\text{C}$  to  $+70^{\circ}\text{C}$ , UV and humidity resistant. When mounted horizontally, the bellows must be fitted with suitable support rings. For lengths longer than 1000 mm stroke, an extension block is necessary. Comes with 2 galvanised hose clips.

Code	a	d	ZD	AZ	Stroke	D1	D2	kg
ZE-5-FB-500	10	29	100	600	500	38	68	0,3
ZE-5-FB-800	10	29	120	920	800	38	68	0,5
ZE-10-FB-700	10	39	100	800	700	38	78	0,4
ZE-10-FB-1000	10	39	150	1150	1000	38	78	0,6
ZE-25-FB-700	15	46	100	800	700	65	105	0,5
ZE-25-FB-1000	15	46	120	1120	1000	65	105	0,7
ZE-35/50-FB-600	15	60	72	672	600	65	105	0,4
ZE-35/50-FB-1000	15	60	130	1130	1000	65	105	0,7
ZE-35/50-FB-1200	15	60	125	1325	1200	65	105	0,9
ZE-35/50-FB-1500	15	60	180	1680	1500	65	105	1,1
ZE-100-FB-600	15	85	72	672	600	70	110	0,4
ZE-100-FB-1000	15	85	130	1130	1000	70	110	0,7
ZE-100-FB-1500	15	85	180	1680	1500	70	110	1,1
ZE-150-FB-600	15	90	72	672	600	110	150	0,7
ZE-150-FB-1000	15	90	130	1130	1000	110	150	1,1
ZE-150-FB-1500	15	90	180	1680	1500	110	150	1,7
ZE-200-FB-600	15	110	72	672	600	110	150	0,7
ZE-200-FB-1000	15	110	130	1130	1000	110	150	1,1
Z-250-FB-600	15	120	72	672	600	110	150	0,4
Z-250-FB-1000	15	120	130	1130	1000	110	150	0,6
Z-250-FB-1500	15	120	180	1680	1500	110	150	0,82
Z-350-FB-900	15	145	108	1008	900	150	200	0,7
Z-350-FB-1500	15	145	180	1680	1500	150	200	1,1



**Bellows fixing ring FBR**

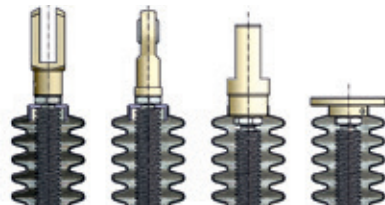

with with without without

The fixing ring FBR is used to secure the bellows FB to the forked end GK or rod end KGK. If a forked end GK or rod end KGK is included in the scope of the order, the fixing ring is supplied automatically. Otherwise, please order it separately.

Material: POM (plastic)

### Ordering example

ZE-25-FBR



**Bellows adapter FBA**

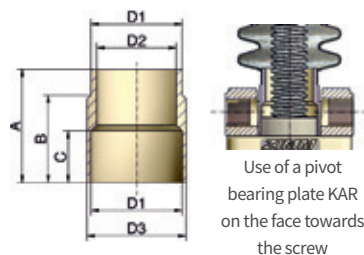

Code	D1	D2	D3	A	B	C
ZE-5-FBA	29	25	32	44	32	20
ZE-10-FBA	39	30	42	42	32	22
ZE-25-FBA	46	40	50	57	42	26
ZE-35/50-FBA	60	52	65	70	52	40
ZE-100-FBA	85	80	90	90	72	50
ZE-150-FBA	90	85	95	100	82	50

Material: Aluminium

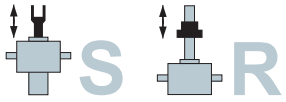

# Accessories

**Spiral spring SF** | Add-on component for translating and rotating version



**Spiral spring cover attachment for types SN/SL**

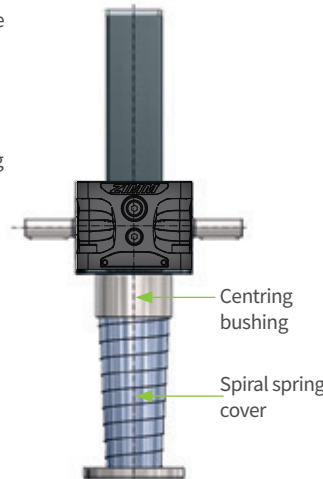
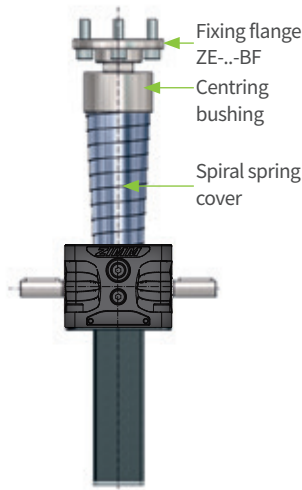
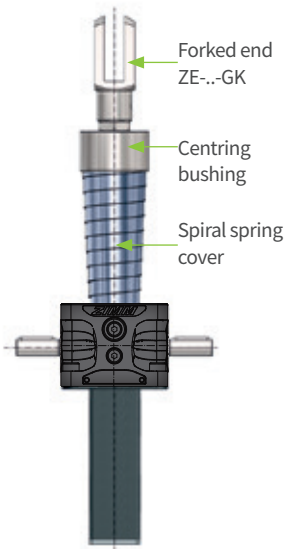

**Spiral spring cover attachment for types RN/RL**

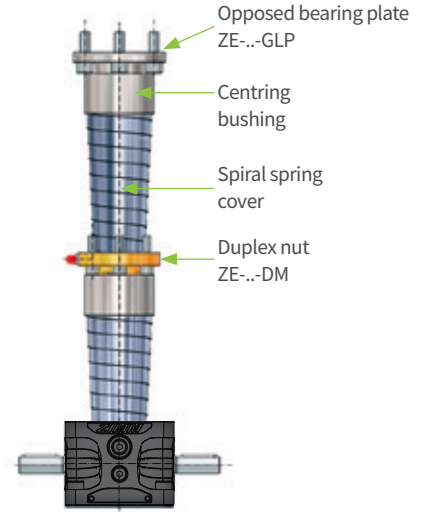

**Fitting instructions:**

The SF spiral spring is usually used when the use of a bellows is not possible. For example, when sharp-edged chips accumulate or if mechanical protection of the spindle is necessary. Centring bushings are required when assembling combinations of different parts; we can include these in our quotation on request.

**IMPORTANT!**

Spiral springs must under no circumstances be allowed to uncoil. For technical reasons, please specify in your enquiry whether the spiral spring is to be installed horizontally or vertically.

If installation is to be vertical, we recommend that the larger diameter is at the top, as shown; if it is to be horizontal, the taper should be away from the direction of flow of the chips or other particulate. As a result, the SF has a self-cleaning effect under normal conditions due to overlapping of the windings.

In the case of heavy soiling, regular cleaning is necessary to prevent malfunctions. A slight film of oil on the spiral spring improves its operation and extends its service life.



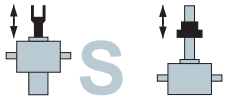

## Accessories

### Spiral spring SF | Cover for standing and rotating version

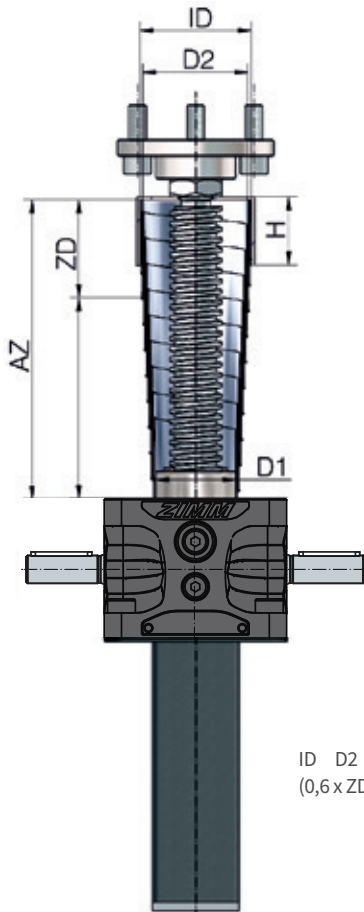

$$ID = D2 + 4 \text{ mm}$$

$$(0,6 \times ZD) \leq H \leq (ZD - 2 \text{ mm})$$

#### Technical data

**Spiral spring SF:** Spring band steel, blued  
(on request we can also supply versions in stainless steel)

**Centring bushing SFZ:** Plastic (other materials on request)

**CAUTION!:** The spring travel quoted is the maximum possible. For practical operation, please allow a margin of safety to prevent damage! We recommend preparation of a drawing to determine the fitting position and dimensions of spiral springs. Other sizes of spiral springs are available on request.

**Ordering example:** **SF-030-0450-030-H SFZ-ID57-H20**

Spiral spring \_\_\_\_\_  
 Least diameter D1 \_\_\_\_\_  
 Greatest length AZ\* \_\_\_\_\_  
 Least length ZD \_\_\_\_\_  
 H = horizontal installation \_\_\_\_\_  
 V = vertical installation \_\_\_\_\_  
 Centring bushing \_\_\_\_\_  
 Inner diameter \_\_\_\_\_  
 Height \_\_\_\_\_

\*For horizontal installation, this value is reduced by up to 1/3 depending on the size of the spiral spring. The max. stroke according to the table must be observed.

Size ZE-5 - SF (Screw jack)						Centring bushing SFZ		
Code	D1	D2	ZD	Stroke	kg	ID	AD	H
030-0450-030-V	30	53	30	420	0,3	57	61	20
030-0450-030-H	30	53	30	360	0,3	57	61	20

Size ZE-10 - SF (Screw jack)						Centring bushing SFZ		
Code	D1	D2	ZD	Stroke	kg	ID	AD	H
040-0450-040-V	40	64	40	410	0,53	69	73	30
040-0450-040-H	40	64	40	350	0,53	69	73	30
040-0900-060-V	40	70	60	840	1,09	74	78	36
040-0900-060-H	40	70	60	720	1,09	74	78	36
040-1300-075-V	40	84	75	1225	2,2	88	92	50
040-1300-075-H	40	84	75	1075	2,2	88	92	50

Size ZE-25 - SF (Screw jack)						Centring bushing SFZ		
Code	D1	D2	ZD	Stroke	kg	ID	AD	H
050-0450-050-V	50	70	50	400	0,64	74	78	36
050-0450-050-H	50	70	50	300	0,64	74	78	36
050-0750-060-V	50	80	60	690	1,07	84	88	40
050-0750-060-H	50	80	60	570	1,07	84	88	40
050-1200-075-V	50	94	75	1125	2,45	98	104	50
050-1200-075-H	50	94	75	975	2,45	98	104	50
050-1500-100-V	50	88	100	1400	2,7	92	96	60
050-1500-100-H	50	88	100	1300	2,7	92	96	60

Size ZE-35, ZE-50 - SF (Screw jack)						Centring bushing SFZ		
Code	D1	D2	ZD	Stroke	kg	ID	AD	H
065-0450-050-V	65	88	50	400	0,64	92	96	35
065-0450-050-H	65	88	50	300	0,64	92	96	35
065-1100-075-V	65	107	75	1025	2,5	112	118	60
065-1100-075-H	65	107	75	825	2,5	112	118	60
065-1500-100-V	65	108	100	1400	3,8	112	118	60
065-1500-100-H	65	108	100	1300	3,8	112	118	60
065-2100-120-V	65	113	120	1980	5,65	118	124	80
065-2100-120-H	65	113	120	1740	5,65	118	124	80

Size ZE-50/Tr50, ZE-100 - SF (Screw jack)						Centring bushing SFZ		
Code	D1	D2	ZD	Stroke	kg	ID	AD	H
090-0650-075-V	90	124	75	575	2,8	128	134	50
090-0650-075-H	90	124	75	425	2,8	128	134	50
090-1300-100-V	90	132	100	1200	4,9	136	142	60
090-1300-100-H	90	132	100	1000	4,9	136	142	60

ZE-50/Tr50 = increased screw (ZE-50-S with 50x8-Screw instead of 40x7).

Size ZE-150 - SF (Screw jack)						Centring bushing SFZ		
Code	D1	D2	ZD	Stroke	kg	ID	AD	H
100-0800-075-V	100	138	75	725	3,7	143	149	51
100-0800-075-H	100	138	75	575	3,7	143	149	51
100-1500-100-V	100	146	100	1400	6	150	156	75
100-1500-100-H	100	146	100	1200	6	150	156	75

#### CAUTION!

The spring travel quoted is the maximum possible. For practical operation, please allow a margin of safety to prevent damage! We recommend preparation of a drawing to determine the fitting position and dimensions of spiral springs. Other sizes of spiral springs are available on request.



# S R Pivot bearing plate KAR



Axis of pivoting **P**  
 (parallel to the drive)

Pivot bearing plate KAR

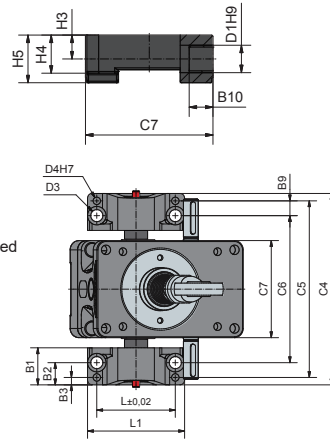
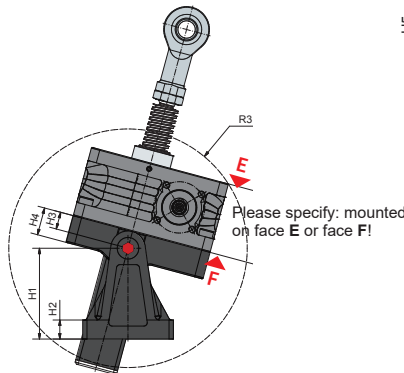

**Lubrication**

The bronze bushings in the gearbox are PTFE-coated and therefore do not need to be lubricated during normal operation. For heavy loads we recommend regular lubrication.

For large motors, long strokes and a high operating cycle, the variant with the slide bearing plate KAR is to be preferred because then the motor weight is absorbed by the pivot bearing plate and does not affect the spindle.

Code	B1	B2	B3	B9	B10	C4	C5	C6	C7	D1	D3	D4	H1	H2	H3	H4	H5	L1	L2	R3	kg
ZE-5-KAR	40	25	10	15	15	166	146	116	74	16	11	8	80	18	15	21	30	90	70	100	0,2
ZE-10-KAR	40	25	10	15	15	179	159	129	87	16	11	8	80	18	15	24	30	90	70	116	0,3
ZE-25-KAR	40	24	8	16	20	207	191	159	107	20	13	8	105	21	20	32	40	105	85	138	0,8

Material: aluminium, corrosion-resistant Other sizes of pivot arrangements **R** and **P** are available on request.



Axis of pivoting **R**  
 (at right angles to drive)

Pivot bearing plate ZE-35-KAR

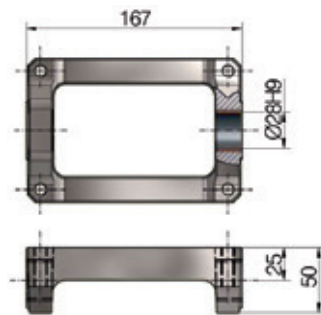

**Multiple system control**  
 With the pivot bearing plate KAR you can control and connect a setup of multiple gearboxes lined up in a row.

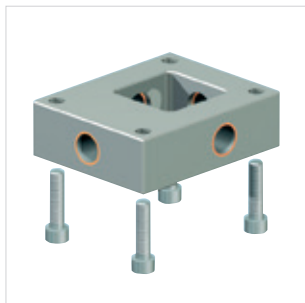

Pivot bearing plate GSZ-KAR (2 to 150)

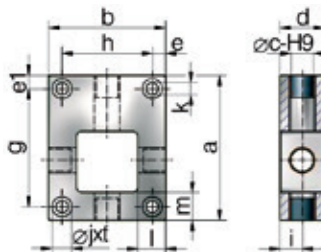

Code	a	b	c	d	e	e1	g	h	i	j	k	l	m	t	kg
GSZ-2-KAR <sup>1)</sup>	70	50	16	30	6	6	48	38	13	13	6,6	11	13	8	0,16
GSZ-5-KAR	80	72 <sup>2)</sup>	16	30	10	10	60	52	15	15	9	18	10	9	0,8
GSZ-10-KAR	100	85 <sup>2)</sup>	16	30	11	11	78	63	15	15	9	16	11	9	1,15
GSZ-25-KAR	130	105 <sup>2)</sup>	20	40	12	12	106	81	20	18	11	25	25	11	2,8
GSZ-50-KAR	180	145	30	50	15	15	150	115	25	20	13	24	30	13	5,3
GSZ-100-KAR	200	175	40	70	22	17	166	131	35	26	17	40	30	18	11,1
GSZ-150-KAR	220	205	50	80	25	25	170	155	40	33	22	40	28	22	13,47

Material: steel, corrosion-resistant. 1) GSZ-2-KAR: aluminium, corrosion-resistant. Delivery incl. screws.

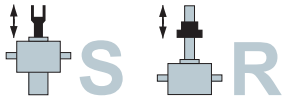

# Accessories



**Fixing strips BFL**

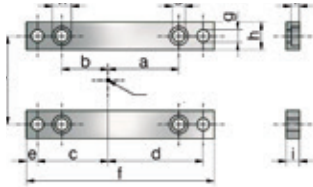

Code	a	b	c	d	e	f	g	h	i	j	k	l	kg
GSZ-2-BFL	32	16	29,5	45,5	7,5	90	6,6	14	10	38	11	6,4	0,16
GSZ-5-BFL	39	21	41	59	10	120	9	20	10	52	14	6	0,32
GSZ-10-BFL	49	29	50	70	10	140	9	20	14	63	14	6	0,5
GSZ-25-BFL	64	42	64	86	10	170	11	25	12	81	17	7,5	0,75
GSZ-50-BFL	87	63	90	114	13	230	13	30	20	115	19	7	2
GSZ-100-BFL	100	66	101	135	17	270	18	40	25	131	26	11	3,7
GSZ-150-BFL	100	70	115	145	20	300	22	50	35	155	33	13	6,75

Material: steel, corrosion-resistant / GSZ-2-BFL: stainless steel  
 Delivery incl. screws



**Handwheel HR**

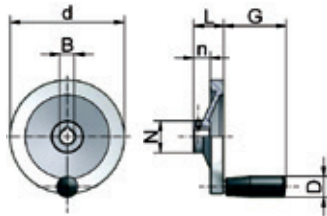

Code	d	N	b	n	L	G	D	B H7 pilot hole	B H7 with nut	kg
HR-080	80	26	13	16	26	42,5	18	8	9/11	0,16
HR-125	125	31	15	18	33	67,5	23	6	11/14	0,3
HR-160	160	36	18	20	39	82,5	26	6	14/16/19	0,5
HR-200	200	42	20,5	24	45	82,5	26	16	16/19/20	1
HR-250	250	48	23	28	51	92,5	28	22	20/25	1,3

Material: Aluminium, plastic (handle)  
 Design: No more than max. 50 - 60 N force should be required at the handle.



**Protective cap GSZ-2-SK**

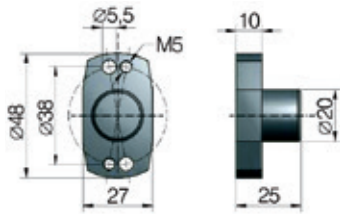

Code	D	d	E	F	Screws DIN 912	kg
GSZ-2-SK	20	5,5/M5	25	10	M5x55	0,05

Incl. screws  
 Material: hard anodised aluminium.

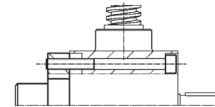

**M5x55**  
 Screws are included with the protective cap

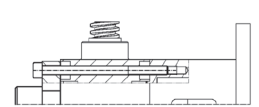

**M5x77**  
 Screws are included with the motor flange / bevel gearbox



**Protective cap SK**

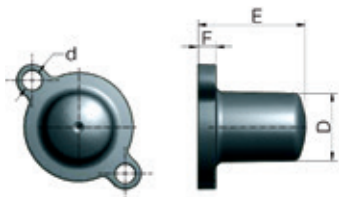

incl. screws

Code	D	d	E	F	Screws DIN 912	kg
ZE-5-SK	25	7	32	8	M6x16	0,02
ZE-10-SK	30	9	32	8	M8x16	0,04
ZE-25-SK	31	9	49	8	M8x16	0,05
ZE-35-SK	35	11	54	8	M10x20	0,07
ZE-50-SK	35	11	55	8	M10x20	0,08
ZE-100/150-SK	46	13,5	74	8	M12x25	0,13
ZE-200-SK	60	17,5	82	25	M16x25	0,50
Z-250-SK	60	17,5	82	25	M16x30	0,7
Z-350-SK	75	20	85	30	M18x30	0,9
Z-500-SK	90	22	125	35	M20x40	1,2
Z-750-SK	110	22	122	28	M20x40	1,5
Z-1000-SK	100	26	142	30	M24x40	2,2

Incl. screws  
 Material: ZE-5 to ZE-200: PA6 GF15, up to 120°C, briefly 180°C.  
 Material: Z-250 to Z-1000: POM, up to 100°C, briefly 140°C.

Suitable for screw jacks ZE, Z, GSZ and KSZ-H bevel gearbox (see chapter 5).

**CAUTION**

For bevel gearboxes, the protective cap must be the same size as the motor flange.

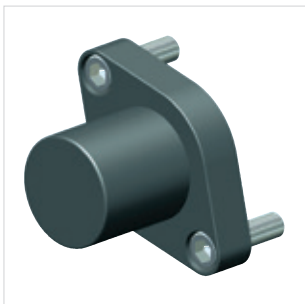

ZE-200 to Z-1000

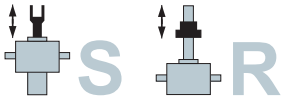

# Accessories

## Motor flange MF | GSZ-2, ZE-5 to ZE-25

### Motor flange MF - GSZ-2

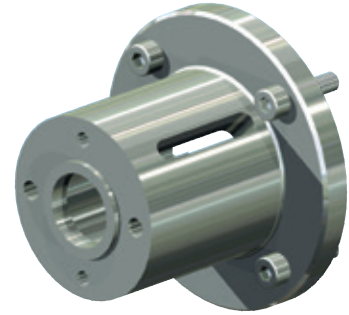
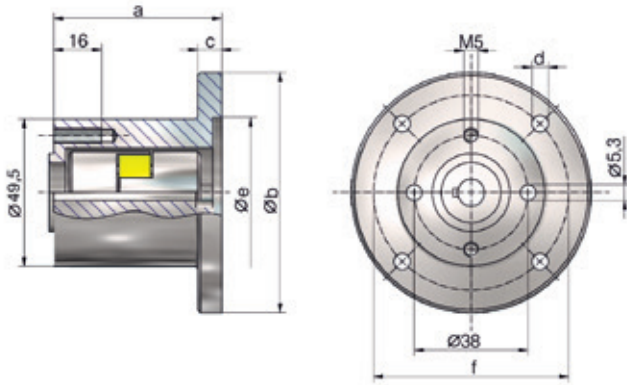

Code	Motor type	Coupling Code Bore - Ø			2 screws gearbox side 8.8	4 screws motor side 8.8 DIN 912 for motor incl. spring washers	a	Øb	c	Ød	Øe	Øf	kg
		Size	Gearbox	Motor									
GSZ-2-MF-80-51 <sup>2)</sup>	56 B14C	KUZ-09	9	9	M5x55, M5x70	M5x20	51	80	9	5,5	50	65	0,22
GSZ-2-MF-80-41+P-120-15 <sup>3)</sup>	63 B14B	KUZ-14	9	11	M5x55, M5x70, M5x45	M6x25	56	120	15	6,6	80	100	0,55
GSZ-2-MF-80-51+P-105-15 <sup>2)</sup>	71 B14C	KUZ-14	9	14	M5x55, M5x70	M6x20	66	105	15	6,6	70	85	0,45

Material: hard anodised aluminium. Delivery incl. screws

1) Screws are included for all the various fitting options

2) For LB parallel to the drive axis, restricted pivot bearing range

3) LB parallel to drive axis not possible

### Motor flange MF

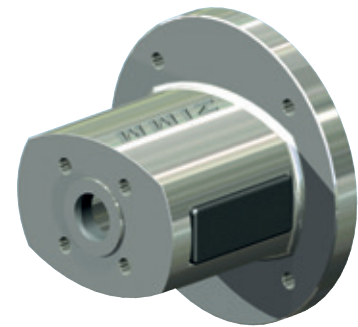
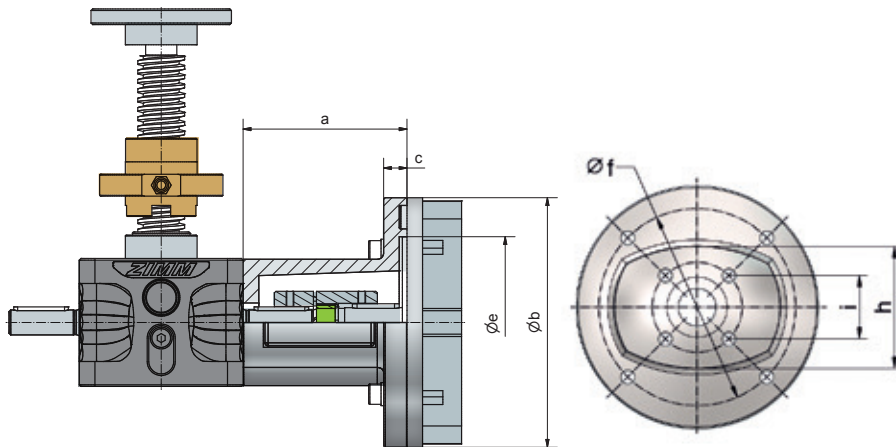

Code	Motor type	Coupling code Bore - Ø			4 screws gearbox side 8.8	4 of socket head cap 8.8 DIN 912 for motor	a	b	c	e	f	h	i	kg
		Size	Gearbox	Motor										
ZE-5-MF-120-60	63 B14B	KUZ-14	11	11	M6x12 - DIN 7991	M6x20 + spring washers	60	120	10	80	100	61	32,5	0,3
ZE-5-MF-105-68	71 B14C	KUZ-19	11	14	M6x12 - DIN 7991	M6x20 + spring washers	68	105	10	70	85	61	32,5	0,3
ZE-10-MF-120-66	63 B14B	KUZ-19	14	11	M8x16 - DIN 7991	M6x20 + spring washers	66	120	10	80	100	73	35,4	0,4
ZE-10-MF-160-75	71 B5	KUZ-19	14	14	M8x16 - DIN 7991	M8x35 + nuts	75	160	15	110	130	73	35,4	0,8
ZE-10-MF-160-90	80 B14B	KUZ-24	14	19	M8x16 - DIN 7991	M8x30 + spring washers	90	160	15	110	130	73	35,4	0,8
ZE-25-MF-160-105	71 B5	KUZ-28	16	14	M8x20 - DIN 7991	M8x35 + nuts	105	160	15	110	130	81	42	1,1
ZE-25-MF-160-105	80 B14B	KUZ-24	16	19	M8x20 - DIN 7991	M8x30 + spring washers	105	160	15	110	130	81	42	1,1
ZE-25-MF-160-105	90 B14B	KUZ-24	16	24	M8x20 - DIN 7991	M8x30 + spring washers	105	160	15	110	130	81	42	1,1
ZE-25-MF-160-122	100 B14C	KUZ-28	16	28	M8x20 - DIN 7991	M8x30 + nuts	122	160	15	110	130	81	42	1,2

Material: Aluminium, all screws galvanized nut DIN 934 and spring washers DIN 128. Delivery incl. screws

**S R Accessories**  
**Motor flange MF | ZE-35 to ZE-200**

**Motor flange MF**

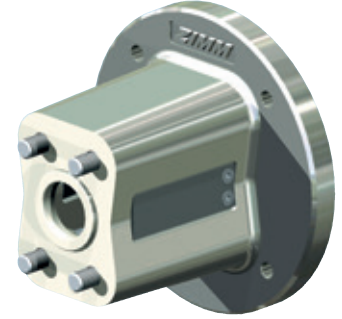
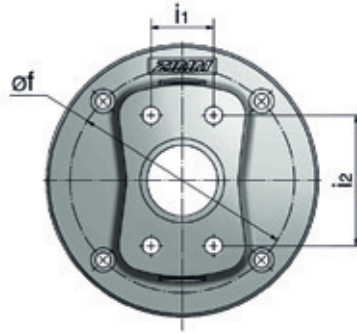
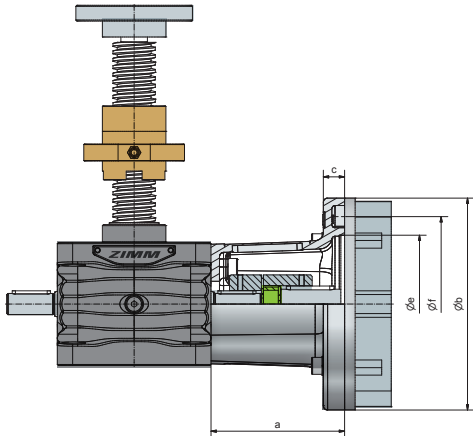

**Motor flange base MF-B and motor flange plate MF-P - ZE-35 to ZE-200**

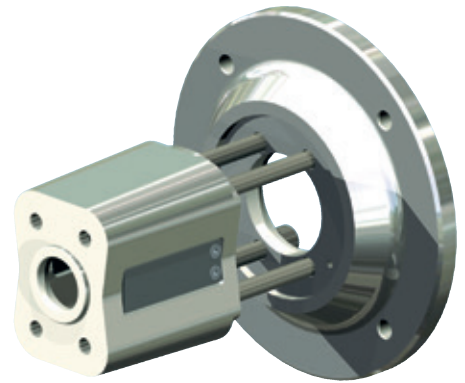
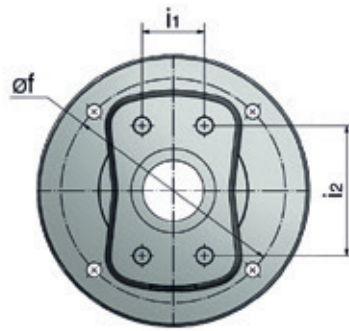
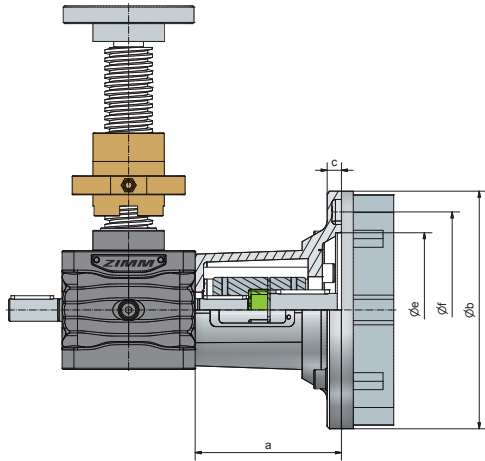

Code	Motor type	Coupling code			4 screws gearbox side DIN 912	4 screws motor side DIN 912	a	b	c	e	f	i1	i2	kg
		Size	Gearbox	Motor										
ZE-35-MF-160-111	80 B14B	KUZ-24	19	19	M10x30	M8x25 <sup>1)</sup>	111	160	15	110	130	36	62	2,7
ZE-35-MF-160-111	90 B14B	KUZ-24	19	24	M10x30	M8x25 <sup>1)</sup>	111	160	15	110	130	36	62	2,7
ZE-35-MF-B + ZE-35-MF-P-200	100 B14B	KUZ-28	19	28	M10x120	M10x30 <sup>1)</sup>	123	200	12	130	165	36	62	3,6
ZE-35-MF-B + ZE-35-MF-P-200	112 B14B	KUZ-28	19	28	M10x120	M10x30 <sup>1)</sup>	123	200	12	130	165	36	62	3,6
ZE-35-MF-B + special plate	Servomotors, geared motors, Nema, ...													
ZE-50-MF-200-116	90 B5	KUZ-28	20	24	M10x30	M10x45 <sup>2)</sup>	116	200	20	130	165	50	70	4,1
ZE-50-MF-200-126	100 B14B	KUZ-28	20	28	M10x30	M10x35 <sup>1)</sup>	126	200	20	130	165	50	70	4,3
ZE-50-MF-200-126	112 B14B	KUZ-28	20	28	M10x30	M10x35 <sup>1)</sup>	126	200	20	130	165	50	70	4,3
ZE-50-MF-B + special plate	Servomotors, geared motors, Nema, ...													
ZE-100/150-MF-200-138	100 B14B	KUZ-28	25	28	M12x40 <sup>3)</sup>	M10x35 <sup>1)</sup>	138 <sup>3)</sup>	200	20	130	165	46	96	5,3
ZE-100/150-MF-200-138	112 B14B	KUZ-28	25	28	M12x40 <sup>3)</sup>	M10x35 <sup>1)</sup>	138 <sup>3)</sup>	200	20	130	165	46	96	5,3
ZE-100/150-MF-B + P-200	132 B14C	KUZ-38	25	38	M12x150 <sup>3)</sup>	M10x65 <sup>1)</sup>	161 <sup>3)</sup>	200	48	130	165	46	96	8,7
ZE-100/150-MF-B + special plate	Servomotors, geared motors, Nema, ...													
ZE-200-MF-200-168	100 B14B	KUZ-38	28	28L	M16x45	M10x40 <sup>1)</sup>	168	200	20	130	165	56	100	8,1
ZE-200-MF-200-168	112 B14B	KUZ-38	28	28L	M16x45	M10x40 <sup>1)</sup>	168	200	20	130	165	56	100	8,1
ZE-200-MF-200-168	132 B14C	KUZ-38	28	38	M16x45	M10x40 <sup>1)</sup>	168	200	20	130	165	56	100	8,1
ZE-200-MF-200-168 + P-350	160 B5	KUZ-45	28A	42	M16x45	M16x70 <sup>2)</sup>	198	350	30	250	300	56	100	24,8
ZE-200-MF-200-168 + special plate	Servomotors, geared motors, Nema, ...													

Material: GGG-50, corrosion-resistant, all screws galvanized nut DIN 934 and spring washers DIN 128. Delivery incl. Screws.

1) incl. spring washers

2) incl. nuts and spring washers

3) Threaded bolt 8.8 with nuts and spring washers



# Accessories

## Motor flange MF | Z-250 to Z-1000

### Motor flange MF



### Motor flange base MF-B and motor flange plate MF-P - Z-350 to Z-500

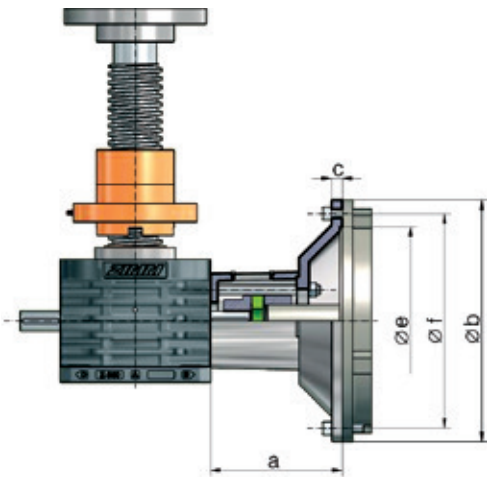

Code	Motor type	Coupling code Bore - Ø			4 screws gearbox side DIN 912	4 screws motor side DIN 912	a	b	c	e	f	kg
		Size	Gearbox	Motor								
Z-250-MF-200-168	100 B14B	KUZ-38	28L	28L	M16x55	M10x40 <sup>1)</sup>	168	200	20	130	165	8,5
Z-250-MF-200-168	112 B14B	KUZ-38	28L	28L	M16x55	M10x40 <sup>1)</sup>	168	200	20	130	165	8,5
Z-250-MF-200-168	132 B14C	KUZ-38	28	38	M16x55	M10x40 <sup>1)</sup>	168	200	20	130	165	8,5
Z-250-MF-200-168 + P-350	160 B5	KUZ-45	28A	42	M16x55	M16x70 <sup>2)</sup>	198	350	30	250	300	20,5
Z-250-MF-200-168 + P-350	180 B5	KUZ-55	28A	48	M16x55	M16x70 <sup>2)</sup>	198	350	30	250	300	20,5
Z-250-MF-200-168 + P-400	200 B5	KUZ-55	28A	55	M16x55	M16x70 <sup>2)</sup>	200	400	32	300	350	25
Z-250-MF-200-168 + special plate	Servomotors, geared motors, Nema,...											
Z-350-MF-B + P-350	180 B5	KUZ-55	38A	48	4x M18x230	M16x60 <sup>2)</sup>	211	350	19	250	300	24
Z-350-MF-B + P-400	200 B5	KUZ-55	38A	55	4x M18x230	M16x60 <sup>2)</sup>	211	400	19	300	350	27
Z-350-MF-B + P-450	225 B5	KUZ-60	38A	60	4x M18x230	8x M16x60 <sup>2)</sup>	243	450	19	350	400	33
Z-350-MF-B + special plate	Servomotors, geared motors, Nema,...											
Z-500-MF-SO	Dimensions on request											
Z-750-MFSO	Dimensions on request											
Z-500-MF-B + special plate	Dimensions on request - Servomotors, geared motors, Nema,...											
Z-750 und Z-1000 motor flange on request												

Material: GGG-50, corrosion-resistant, all screws galvanized nut DIN 934 and spring washers DIN 128. Delivery incl. screws.

1) incl. spring washers

2) incl. nuts and spring washers

3) Threaded bolt 8.8 with nuts and spring washers

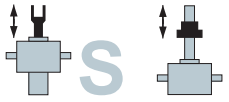

# Three-phase AC motors

## Overview | 0,09 kW - 75 kW

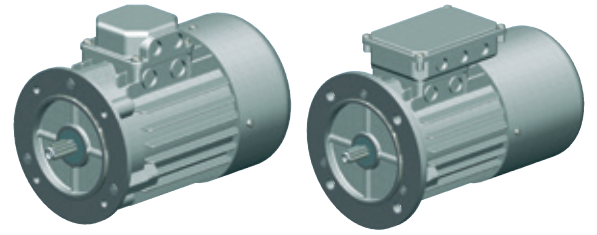

### Technical data

Standard three-phase motors (asynchronous)  
 No-load speed ~1500 rpm (other speeds on request)  
 230/400 V Δ 50 Hz, S1 or S3-75%, ISO F  
 Three-phase AC motors: IP 55  
 Three-phase AC motors with brakes: IP 54

#### Voltage ranges:

220 - 240 V Δ 50 Hz      380 - 415 V VY 50 Hz  
 380 - 415 V Δ 50 Hz      660 - 690 V VY 50 Hz

Size	Power P	Rated speed	Rated torque	Rated current at 400 V	for direct-on-line starting		Breakdown torque to rated torque	Moment of inertia J	Efficiency (at 100% load)	Power factor (at 100% load)	Weight without brake	Weight with brake
IEC	kW	rpm	Nm	A	Starting current to rated current	Starting torque to rated torque	M <sub>k</sub> /M <sub>N</sub>	approx. kgm <sup>2</sup>	η %	cos	approx. kg	approx. kg
					I <sub>s</sub> /I <sub>N</sub>	M <sub>s</sub> /M <sub>N</sub>						
56	0,09	1300	0,66	0,35	2,5	1,8	2	0,0002	50	0,76	2,7	4
63	0,18	1330	1,3	0,65	2,3	1,9	1,9	0,0003	58	0,7	4,1	6
63	0,25*	1340	1,81	0,94	2,2	1,7	2,5	0,0004	60	0,76	4,2	6,5
71	0,37	1360	2,6	1,2	2,8	2	2	0,0008	63	0,7	6	8
71	0,75*	1370	5,33	2,1	2,9	2,1	2,4	0,0012	69	0,78	8,3	10,3
80	0,75	1410	5,1	2	4,5	2,2	2,8	0,0020	70	0,7	9,3	13
80	1,5*	1390	10,4	3,4	4,1	3,2	3,2	0,0026	72	0,7	11,5	15,2
90L	1,5	1410	10,3	3,7	4,9	3	3	0,0032	79	0,74	14,4	18
90L	2,2*	1400	15,2	5,2	4,5	2,7	2,7	0,0039	78	0,81	17,5	21,1
100L	2,2	1420	14,8	5,3	4	2,3	2,7	0,0046	83	0,74	19,2	25,5
100L	3	1410	20,3	6,7	3,9	2,3	2,5	0,0056	82	0,79	22,4	28
100L	4*	1420	27	8,9	4	2,2	2,2	0,0065	81	0,82	26,3	31,9
112M	4	1440	27	9,4	3,3	2,5	2,9	0,0133	83	0,75	30,4	38
112M	5,5*	1440	36,4	11,7	3,9	2,1	2,3	0,0139	84	0,83	33	40,6
132S	5,5	1440	36	12	5,8	3	3	0,024	83	0,8	41,9	56
132M	7,5	1440	50	15,4	6,8	3,1	3,1	0,0293	86	0,82	51	66
132M	11*	1445	73,1	24,5	8,2	3,5	3,5	0,0458	83	0,8	74	89
» 160M	11	1460	72,1	20,7	7,6	2,1	2,4	0,0832	89,1	0,86	101	111
» 160L	15	1460	96,2	29,2	7,1	2,4	2,6	0,1506	89,4	0,83	110	120
» 180M	18,5	1465	119	34,3	7,1	2,3	2,6	0,1773	90,4	0,86	135	150
» 180L	22	1475	142	41,1	6,9	2,4	2,6	0,2936	90,9	0,85	145	160
» 200L	30	1475	190	54	6,6	2,1	2,3	0,6345	92,1	0,87	230	253
» 225S	37	1470	238	64,7	7	2,3	2,5	0,3251	92,8	0,89	338	361
» 225M	45	1470	286	77,9	7,4	2,3	2,4	0,7866	92,6	0,9	358	381
» 250M	55	1465	359	94	7,5	2,6	2,6	0,9483	93,4	0,9	482	517
» 250ML	75	1480	484	134	6,3	1,2	2,2	0,9988	94	0,8	535	570

Size 63 to 132 available on short lead times  
 \*Power is higher than the IEC-Norm (progressive)  
 » Size 160 to 355 available on request

### CAUTION

**Overdimensioning** the motor power risks overstressing other components. The effects must be considered not only under load but also for the no-load case.

We supply **motor brakes** as standard for a connection voltage of 230V AC, operating voltage 205 V DC, with bridge rectifiers.

### Ordering example:

**90-P4-1,5-B5-B-2W**

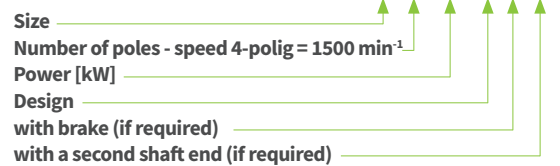



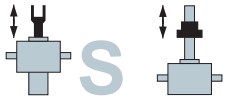

# Three-phase AC motors

## General information

### Connection arrangement

The motors usually have a terminal board with 6 terminals and a protective earth terminal in the terminal box. The stator winding can be switched into star or delta connection using the connection links.

Star/delta starting is not suitable for screw jack systems because full torque is required immediately on starting.

### For motor windings 230/400V (example):

Δ - Connection

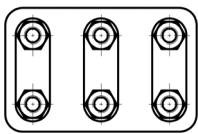

3~ 230V

Y - Connection

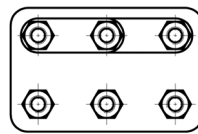

3~ 400V

### Operating voltage 230V delta:

Motor windings 230/400V

### Operating voltage 400V delta:

Motor windings 400/660V

### Direction of rotating

Motors can be arranged for either direction of rotation. When the line phases L1, L2, L3 are connected to the motor terminals U1, V1, W1, the direction of rotation is clockwise. Swapping over two of the supply lines reverses the direction of rotation.

### Speeds

Three-phase AC motors have different rotational speeds depending on the number of poles. Generally we recommend our standard motor with 1500 rpm (4 poles). Other numbers of poles are available on request. Pole-changing motors allow a choice of 2 different rotational speeds.

Speed (50 Hz)	Number of poles
3000	2
1500	4 (= preferred type)
1000	6
750	8
500	12

### Geared motors

Geared motors are available for particular projects on request.

### Operation with frequency converters

Especially for larger screw jacks and systems, we recommend the use of a frequency converter to achieve smooth start-up and brake ramps. This minimizes start-up noise and extends the service life of the gearbox.

When operating with a frequency converter, remember that if the motor is to be operated for extended periods at frequencies less than 25 Hz, its fan must be driven separately. This is necessary to ensure adequate motor cooling. When operating a braked motor with a frequency converter, a separate actuation line for the brake must be provided via the frequency converter.

### Braked motors

We recommend using a braked motor to minimize the overrun time of the system. Where a screw jack is fitted with a ball screw or a double-pitch screw, a braked motor is absolutely essential. We supply motor brakes as standard for a connection voltage of 230V AC / operating voltage 205V DC, with bridge rectifiers. Other connection voltages (24V DC, 400V AC, 500V AC) are available on request.

### Temperature monitoring

Generally we do not supply temperature monitoring because screw jack duty cycles are normally quite low or the motor is adequately dimensioned. Most standard motors above 1.5 kW are equipped with PTC. Versions with bimetal switch (TH), Temperature control thermal resistor PTC (TF) and combined are available on request.

Some types are available ex stock with thermal resistor (PTC).

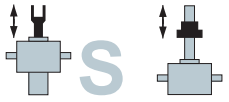

# Three-phase AC motors with brakes

## Flange profile B14B, large flange

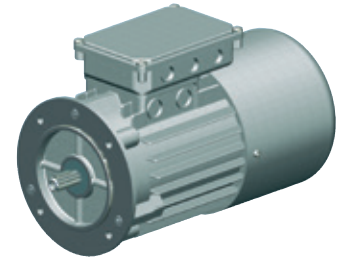
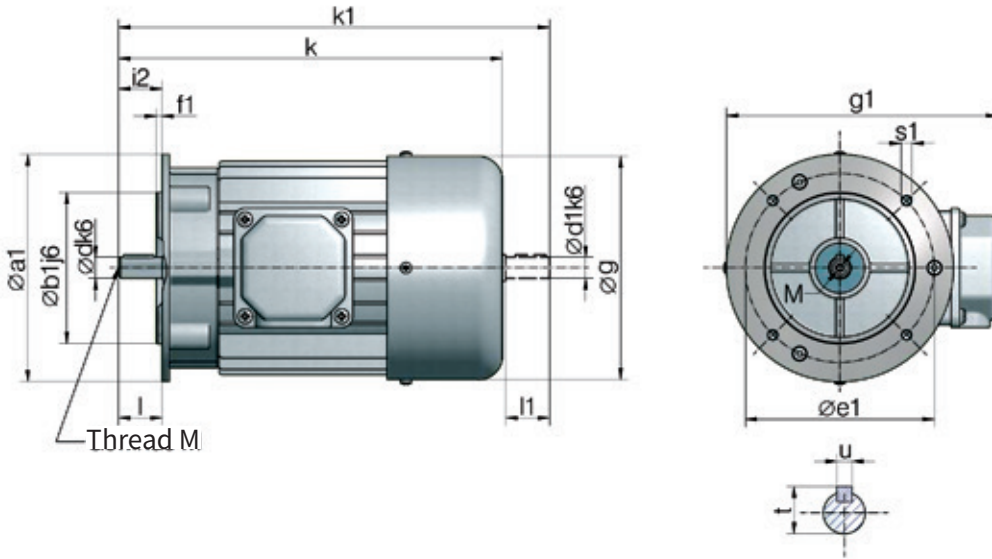

B14: Flange with internal thread  
B: Large flange

Size	a1	b1	e1	f1	g	i2	s1	d	l	t	u
63	120	80	100	3	125	23	M6	11	23	12,5	4
71	140	95	115	3	141	30	M8	14	30	16	5
80	160	110	130	3,5	159	40	M8	19	40	21,5	6
90	160	110	130	3,5	179	50	M8	24	50	27,5	8
100	200	130	165	3,5	199	60	M10	28	60	31	8
112	200	130	165	3,5	223	60	M10	28	60	31	8

These dimensions are standardised and thus always remain the same.

Size	kW		without brake			with brake		with brake and second shaft end			g1	M
	(4-pole)	k	k1	d1	l1	k	k	k1	d1	l1		
63	0,18	212	238	11	23	261	261	285	9	20	172	4
63	0,25	212	238	11	23	239	261	285	9	20	172	4
71	0,37	248	281	14	30	263	295	325	11	23	188	5
71	0,75	248	281	14	30	263	295	325	11	23	188	5
80	0,75	277	315	19	40	305	330	375	19	40	211	6
80	1,5	277	315	19	40	305	330	375	19	40	211	6
90	1,5	329	378	24	50	390	390	432	19	40	227	8
90	2,2	329	378	24	50	348	390	432	19	40	227	8
100	3	369	429	28	60	433	433	487	24	50	248	10
100	4	369	429	28	60	433	433	487	24	50	248	10
112	5,5	391	448	28	60	456	456	511	24	50	266	10

These dimensions are our standard (4-pole), but may vary in individual cases.

We reserve the right to change the dimensions without changing the motor designation.

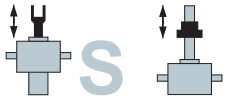

# Three-phase AC motors with brakes

## Flange profile B14C, small flange

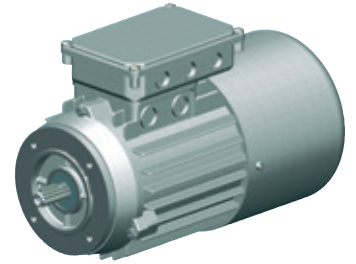
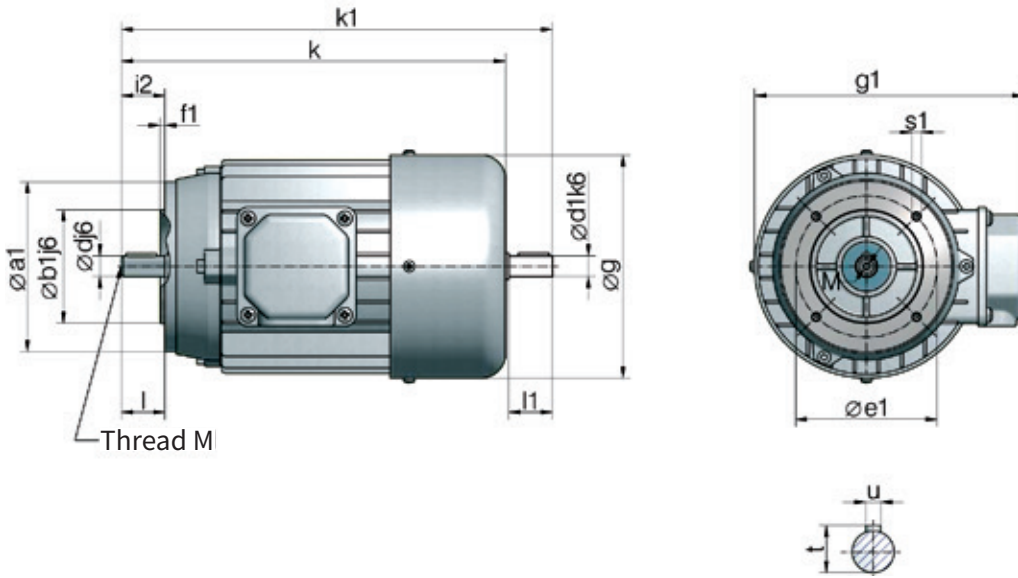

B14: Flange with internal thread  
C: Small flange

Size	a1	b1	e1	f1	g	i2	s1	d	l	t	u
56	80	50	65	2,5	110	20	M5	9	20	10,2	3
63	90	60	75	2,5	125	23	M5	11	23	12,5	4
71	105	70	85	2,5	141	30	M6	14	30	16	5
80	120	80	100	3	159	40	M6	19	40	21,5	6
90	140	95	115	3	179	50	M8	24	50	27	8
100	160	110	130	3,5	199	60	M8	28	60	31	8
112	Dimensions on request										
132	Dimensions on request										

These dimensions are standardised and thus always remain the same.

Size	kW (4-pole)	without brake				with brake		with brake and second shaft end				g1	M
		k	k1	d1	l1	k	k	k1	d1	l1			
56	0,09	189	212	9	20	243	243	-	-	-	161	4	
63	0,18	212	238	11	23	261	261	285	9	20	172	4	
63	0,25	212	238	11	23	239	261	285	9	20	172	4	
71	0,37	248	281	14	30	263	295	325	11	23	188	5	
71	0,75	248	281	14	30	263	295	325	11	23	188	5	
80	0,75	277	315	19	40	305	330	375	19	40	211	6	
80	1,5	277	315	19	40	305	330	375	19	40	211	6	
90	1,5	329	378	24	50	390	390	432	19	40	227	8	
90	2,2	329	378	24	50	348	390	432	19	40	227	8	
100	3	369	429	28	60	433	433	487	24	50	248	10	
100	4	369	429	28	60	433	433	487	24	50	248	10	
112	5,5	391	448	28	60	456	456	511	24	50	266	10	
132	7,5	490	570	38	80	585	-	-	-	-	326	12	

These dimensions are our standard (4-pole), but may vary in individual cases.

We reserve the right to change the dimensions without changing the motor designation.

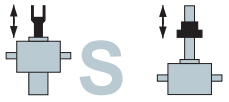

# Three-phase AC motors

## Flange profile B5

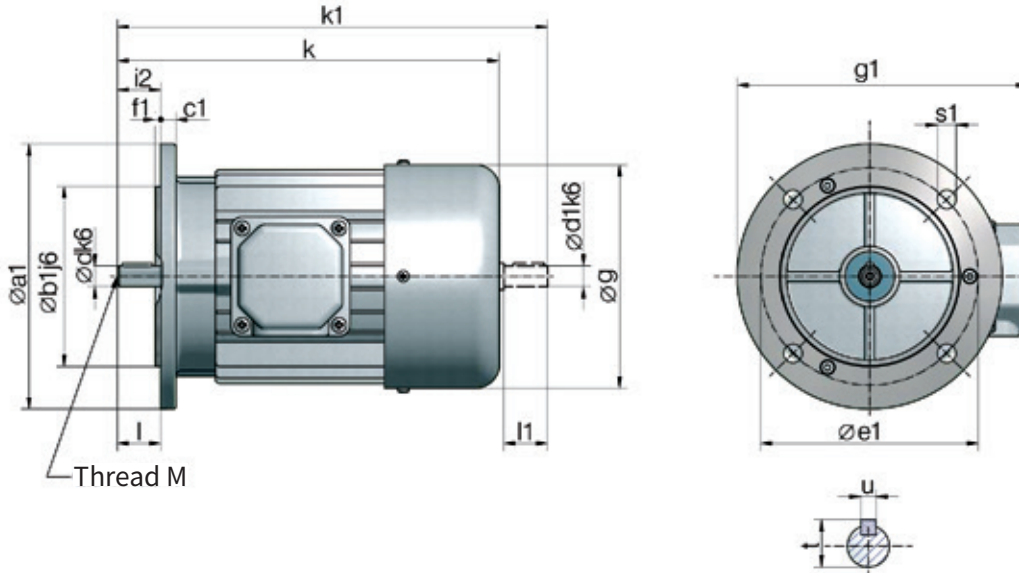

B5: Flange with through holes

Size	a1	b1	e1	c1	f1	g	i2	s1	d	l	t	u
63	140	95	5	115	3	125	23	9,5	11	23	12,5	4
71	160	110	7	130	3,5	141	30	9,5	14	30	16	5
80	200	130	8	165	3,5	159	40	11,5	19	40	21,5	6
90	200	130	8	165	3,5	179	50	11,5	24	50	27	8
100	250	180	10	215	4	199	60	14	28	60	31	8
112	Dimensions on request											

These dimensions are standardised and thus always remain the same.

Size	kW		without brake			with brake		with brake and second shaft end			g1	M
	(4-pole)	k	k1	d1	l1	k	k	k1	d1	l1		
63	0,18	212	238	11	23	261	261	285	9	20	172	4
63	0,25	212	238	11	23	239	261	285	9	20	172	4
71	0,37	248	281	14	30	263	295	325	11	23	188	5
71	0,75	248	281	14	30	263	295	325	11	23	188	5
80	0,75	277	315	19	40	305	330	375	19	40	211	6
80	1,5	277	315	19	40	305	330	375	19	40	211	6
90	1,5	329	378	24	50	390	390	432	19	40	227	8
90	2,2	329	378	24	50	348	390	432	19	40	227	8
100	3	369	429	28	60	433	433	487	24	50	248	10
100	4	369	429	28	60	433	433	487	24	50	248	10
112	Dimensions on request											

These dimensions are our standard (4-pole), but may vary in individual cases.

We reserve the right to change the dimensions without changing the motor designation.

# Three-phase AC motors

## Pedestal mounted type B3

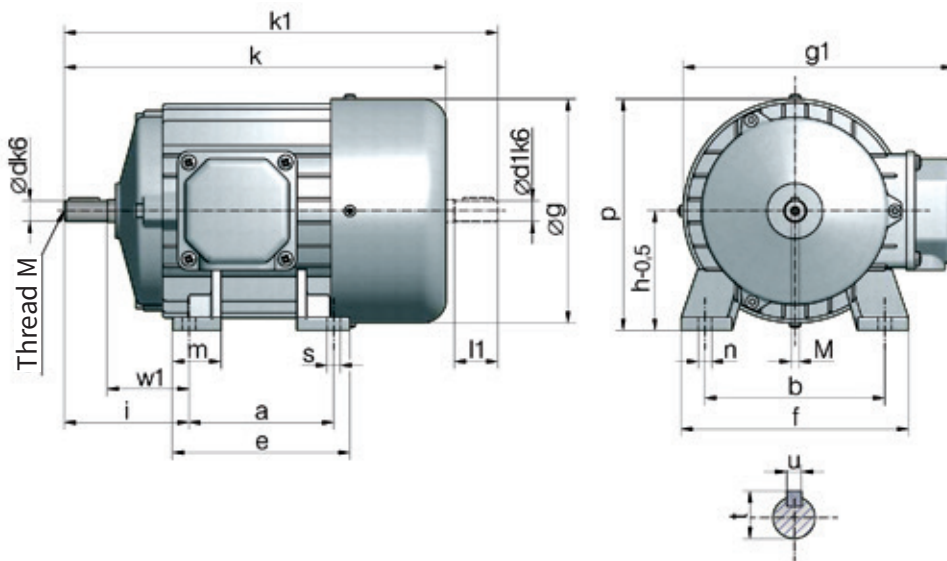
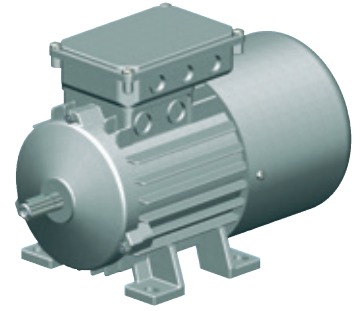
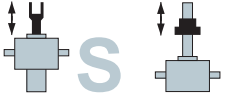

For this type, we can supply a flanged motor (e.g.: B14) with additional pedestal mounts fitted. This version is generally available on a shorter lead time. The dimensions remain the same.

Please specify the terminal box position (top, right or left when looking at the motor shaft). If not otherwise specified, we deliver up to size 112 with the box on top and from size 132 with it on the right.

Size	a1	b1	e1	c1	f1	g	i2	s1	d	l	t	u	u
63	80	100	125	63	63	126	7	11	40	11	23	12,5	4
71	90	112	141	71	75	142	7	7	45	14	30	16	5
80	100	125	159	80	90	160	9	17	50	19	40	21,5	6
90	125	140	179	90	106	180	9	17	56	24	50	27	8
100	140	160	199	100	123	200	12	20	63	28	60	31	8
112	Dimensions on request												
132S	Dimensions on request												
132M	Dimensions on request												
160M	Dimensions on request												
160L	Dimensions on request												
180M	Dimensions on request												
180L	Dimensions on request												
200L	Dimensions on request												

These dimensions are standardised and thus always remain the same.

\*The height g1 is for top-mounted terminal boxes

Size	kW	without brake				with brake		with brake and second shaft end				c	e	f	g1	M
	(4-pol.)	k	k1	d1	l1	k	k	k1	d1	l1						
63	0,18	212	238	11	23	261	261	285	9	20	10	105	120	172	4	
63	0,25	212	238	11	23	239	261	285	9	20	10	105	120	172	4	
71	0,37	248	281	14	30	263	295	325	11	23	11	108	136	188	5	
71	0,75	248	281	14	30	263	295	325	11	23	11	105	136	188	5	
80	0,75	277	315	19	40	305	330	375	19	40	11	125	154	211	6	
80	1,5	277	315	19	40	305	330	375	19	40	11	125	154	211	6	
90	1,5	329	378	24	50	390	390	432	19	40	13	155	174	227	8	
90	2,2	329	378	24	50	348	390	432	19	40	13	155	174	227	8	
100	3	369	429	28	60	433	433	487	24	50	14	175	192	248	10	
100	Dimensions on request															
112	Dimensions on request															
132S	Dimensions on request															
132M	Dimensions on request															
160M	Dimensions on request															
160L	Dimensions on request															

These dimensions are our standard (4-pole), but may vary in individual cases.

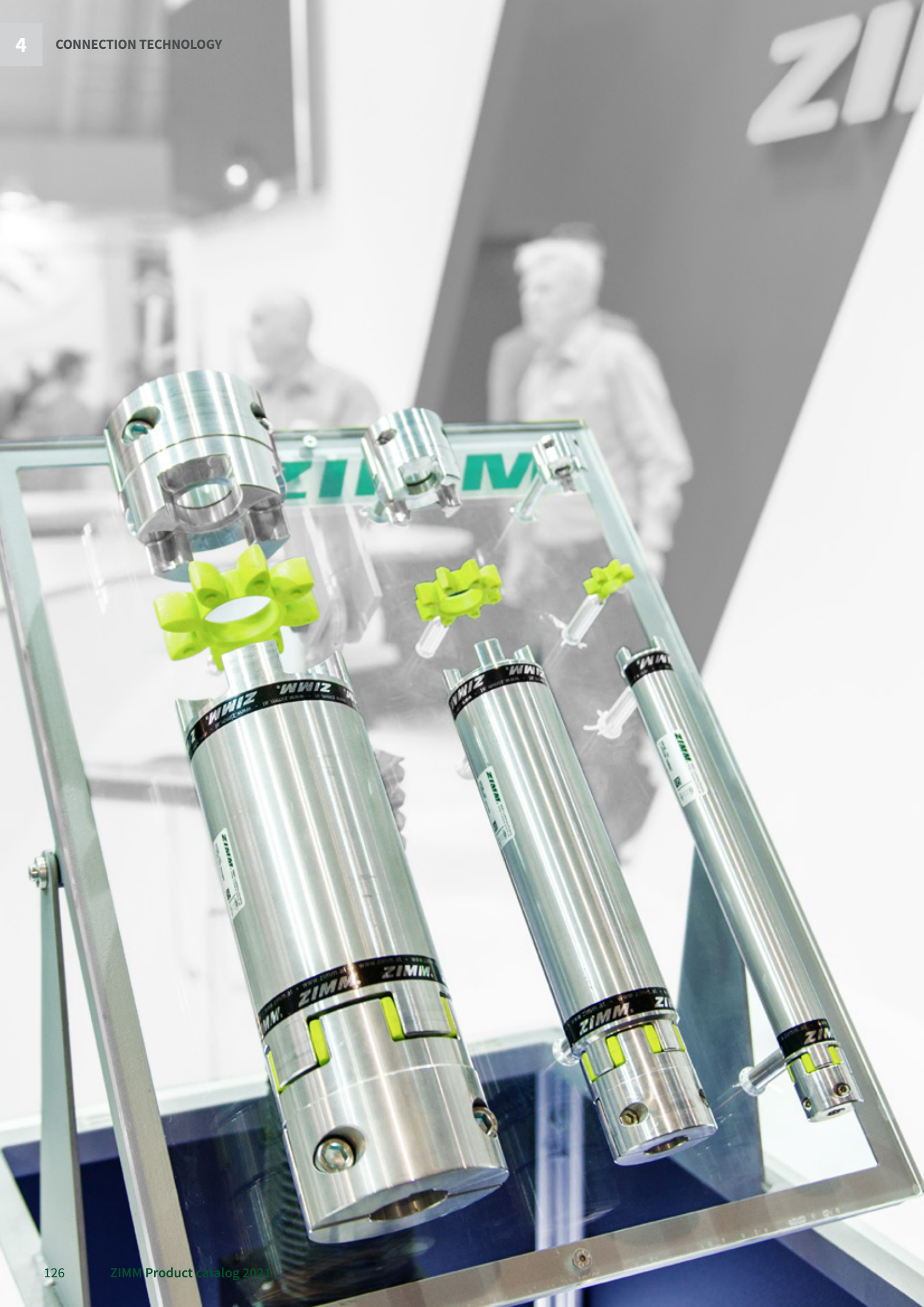

# CHAPTER 4

## Connection technology

### VWZ Connecting shaft

Connecting shaft VWZ	128
Length calculation VWZ	129
Rigid & flexible hub, VWZ for pedestal bearing use STL	130
Pedestal bearing STL for connecting shaft VWZ	131
STL shaft extension	131

### KUZ+ Coupling

Standard coupling KUZ	132
Clamp coupling KUZ-KK	134



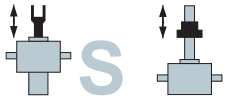

## Connecting shaft VWZ

### Split shells

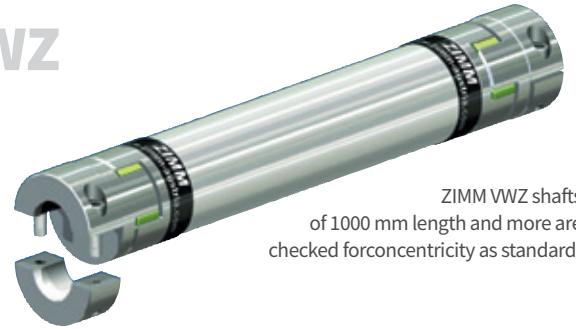
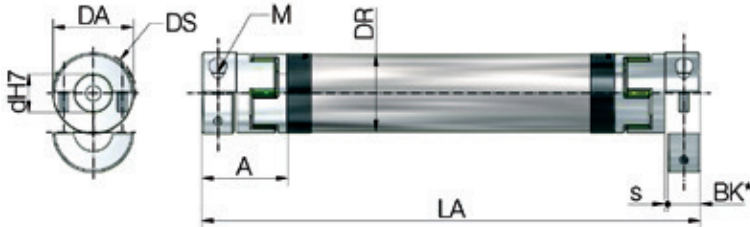

ZIMM VWZ shafts of 1000 mm length and more are checked for concentricity as standard!

#### Standard bores „d“ mm

VWZ-30:	8, 9, 10, 11, 12, 14, 15, 16
VWZ-40:	9, 10, 11, 12, 14, 15, 16, 18,19, 20, 22, 24
VWZ-60:	10, 11, 12, 14, 15, 16, 18, 19, 20, 22, 24, 25, 28, 30, 32
VWZ-60V:	12, 15, 16, 18, 20, 22, 24, 25, 28, 30, 32, 35
VWZ-80:	16, 19, 20, 22, 24, 25, 28, 30, 32, 35, 38, 40, 42, 45
VWZ-100:	25, 28, 32, 38, 40, 42, 45, 48, 50, 55

Other diameters on request

#### Shafts with split shells

Material:	High-tensile aluminium (stainless steel on request)
Insertion:	Split shells permit easy radial insertion
Moment of inertia:	Low
Drive key:	None. Stepless adjustment facility thanks to the clamp hub. Drive keyway available on request
Other features:	High concentricity and clamping forces

#### Elastomer star

Features:	Permanently free of play, dampens vibration
Shore hardness:	64D
Colour:	ZIMM-green
Temperature range:	0°C to +70°C reduced to -20°C, to +100°C (Mx0,55)

#### Dimensions & technical data

Code	Dimensions							Clamping screw		Moment of inertia		Torsional stiffness		Weight	
	DA	DS	DR	BK*	s	A	LA min	M	Tightening torque	per coupling	tube/m	per star	per tube/m	both couplings	tube/m
	mm	mm	mm	mm	mm	mm	mm	10,9	Nm	10 <sup>-3</sup> kgm <sup>2</sup>	10 <sup>-3</sup> kgm <sup>2</sup>	C <sub>tdyn</sub> Nm/rad	C <sub>tdyn</sub> Nm/rad	kg	kg
VWZ-30	32	32	30	15	1,5	34	99	M4	4	0,01	0,11	1375	1104	0,14	0,58
VWZ-40	42	44,5	40	17	1,5	46	133	M5	8	0,08	0,2	3700	2332	0,36	0,76
VWZ-60	56	57	60	30	2	63	177	M6	15	0,24	0,8	9917	8292	0,94	0,97
VWZ-60V	67	68	60	35	2	73	205	M8	35	0,46	0,8	24417	8292	1,42	0,97
VWZ-80	82	85	80	40	2	84	249	M10	70	2,4	3	33667	29102	2,98	2
VWZ-100	102	105	100	50	2	97	283	M12	120	6	5,8	67667	58178	4,62	2,47

\*BK = shaft extension clamping length

#### Drehmomente

Size	Elastomer star		Maxium transmittable torque by clamp hub depending on the bore diameter																	Coupling type		
	Rated torque Nm	Max. torque Nm	Ø9 Nm	Ø11 Nm	Ø14 Nm	Ø16 Nm	Ø19 Nm	Ø20 Nm	Ø22 Nm	Ø24 Nm	Ø25 Nm	Ø28 Nm	Ø30 Nm	Ø32 Nm	Ø38 Nm	Ø40 Nm	Ø42 Nm	Ø45 Nm	Ø48 Nm		Ø55 Nm	
VWZ-30	16	32	21	26	33	37																KUZ-KK-16
VWZ-40	21	42	-	41	52	60	70	74	81	89	-	-	-	-	-	-	-	-	-	-	-	KUZ-KK-24
VWZ-60	75	150	-	60	76	87	104	109	120	131	136	153	164	175	-	-	-	-	-	-	-	KUZ-KK-32
VWZ-60V	200	400	-	-	-	120	-	188	206	-	235	-	-	301	-	-	-	-	-	-	-	KUZ-KK-35
VWZ-80	405	810	-	-	-	325	386	406	447	488	508	568	610	650	772	-	854	915	-	-	-	KUZ-KK-45
VWZ-100	660	1350	-	-	-	-	-	-	-	-	-	570	638	-	730	866	914	960	1029	1097	1250	KUZ-KK-60



#### Concentricity test

ZIMM VWZ shafts of 1000 mm length and more are checked for concentricity as standard!

#### Ordering example:

**VWZ-60-LA 1800-20/25**

Size \_\_\_\_\_  
 Length \_\_\_\_\_  
 Bores of couplings \_\_\_\_\_

n=1500 min<sup>-1</sup> (specify the speed)



# ZE Accessories

## VWZ length calculation

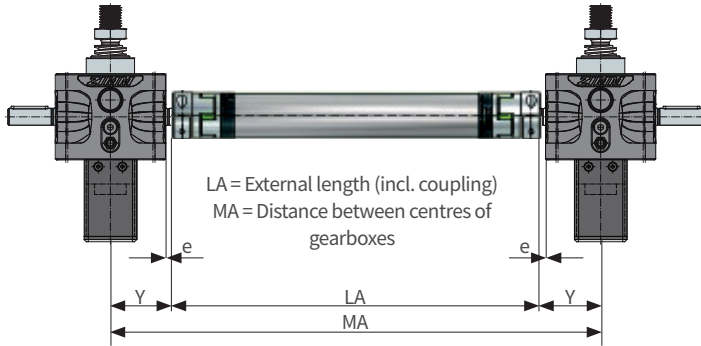

### Installation of the connecting shaft

By using split shell couplings, the connecting shafts can be mounted after the drive shafts have been installed. Simply place the connecting shaft on the spigot and fix the couplings with torque wrench according to the table (feather key not required).

Set the screw tightening torque according to the table.



### Maximum length - dependent on speed

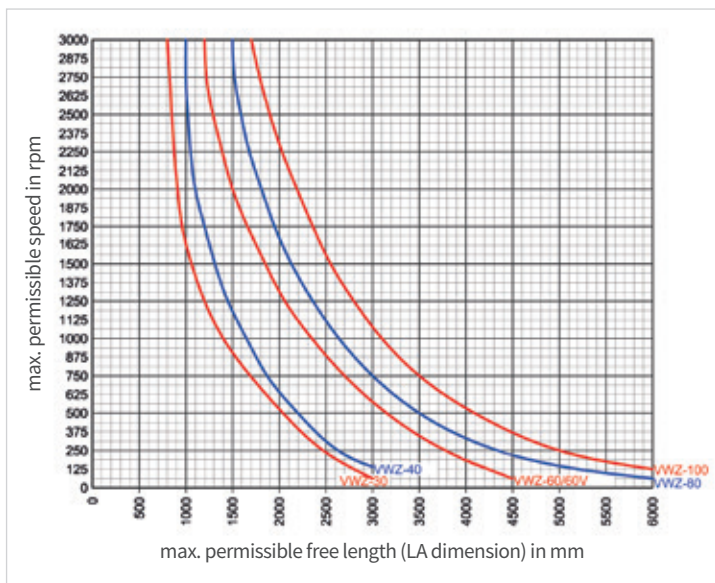

### Length calculation

Screw jack	Connecting shaft	e	Y	A
GSZ-2	VWZ-30	6	31	34
ZE-5	VWZ-30	9	45	34
ZE-5	VWZ-40	7	43	46
ZE-5	VWZ-60	2	38	63
ZE-10	VWZ-30	12,5	55	34
ZE-10	VWZ-40	10,5	53	46
ZE-10	VWZ-60	2,5	45	63
ZE-25	VWZ-40	28	80,5	46
ZE-25	VWZ-60	15	67,5	63
ZE-25	VWZ-80**	5	57,5	84
ZE-35	VWZ-40	28	84	46
ZE-35	VWZ-60	15	71	63
ZE-35	VWZ-60V*	10	66	73
ZE-35	VWZ-80*	5	61	84
ZE-50	VWZ-60	17,5	90	63
ZE-50	VWZ-60V	12,5	85	73
ZE-50	VWZ-80*	7,5	80	84
ZE-100	VWZ-60	30	124	63
ZE-100	VWZ-60V	25	119	73
ZE-100	VWZ-80	20	114	84
ZE-150	VWZ-60	30	130	63
ZE-150	VWZ-60V	25	125	73
ZE-150	VWZ-80	20	120	84
ZE-200	VWZ-60	34	146,5	63
ZE-200	VWZ-60V	29	141,5	73
ZE-200	VWZ-80	24	136,5	84
ZE-200	VWZ-100	14	126,5	97
Z-250	VWZ-80	24	144	84
Z-250	VWZ-100	14	134	97
Z-350	VWZ-80	35	175	84
Z-350	VWZ-100	25	165	97
Z-500	VWZ-80	75	240	84
Z-500	VWZ-100	65	230	97

\*can not be fitted with pivot mounts LB \*\*Outer diameter DS > Gearbox height

### max. permissible offset

Lateral offset ( $\beta$ ):



Angular offset (R):



Axial offset (A):



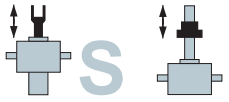

## Connecting shaft for pedestal bearing use | with flexible / rigid hub

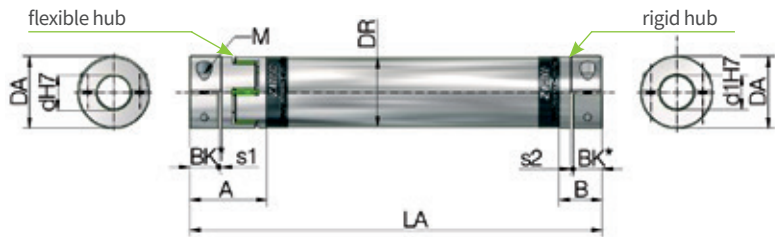

### For pedestal bearing

The installation situation is very important when selecting shaft dimensions. For example, the cost of a larger diameter connecting shaft not requiring additional pedestal bearing support can be considerably less than the cost of a smaller connecting shaft requiring costly sub-structures for the additional pedestal bearing. For this version we use the rigid hub version so that no radial misalignment can occur in the pedestal bearing.

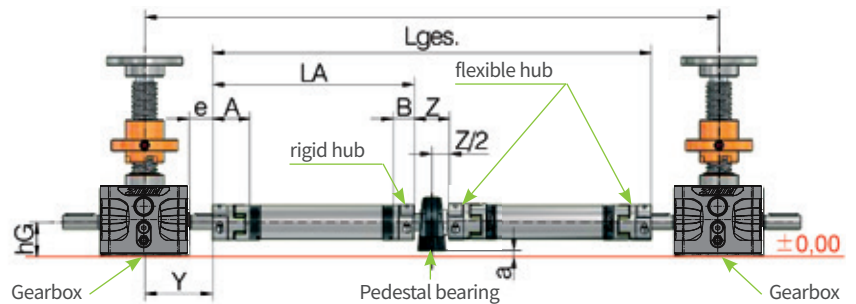

Size	A	B	s1	s2	Bk*	d1	LA min
VWZ-30	34	20	2	1,2	15	15	85
VWZ-40	46	25	2	1,6	17	20	112
VWZ-60	63	40	2	2	30	20	154
VWZ-60V	73	42	2	2	35	30	175
VWZ-80	84	55	2	2	40	30	220
VWZ-100	97	65	2	2	50	50	251

\*BK = shaft extension clamping length

Gearbox	Connecting shaft	e	Y	A	B	Z	Lwz	d1	hG	hL	a
ZE-5	VWZ-30	9	45	34	20	44	74	15	31	30,2	0,8
ZE-5	VWZ-40	7	43	46	25	42	76	20	31	33,3	-2,3
ZE-5	VWZ-60	2	38	63	40	42	102	20	31	33,3	-2,3
ZE-10	VWZ-30	12,5	55	34	20	44	74	15	37	30,2	6,8
ZE-10	VWZ-40	10,5	53	46	25	42	76	20	37	33,2	3,8
ZE-10	VWZ-60	2,5	45	63	40	42	102	20	37	33,2	3,8
ZE-25	VWZ-40	28	80,5	46	25	42	76	20	41	33,2	7,8
ZE-25	VWZ-60	15	67,5	63	40	42	102	20	41	33,2	7,8
ZE-25	VWZ-80	5	57,5	84	55	50	130	30	41	42,9	-1,9
ZE-35	VWZ-40	28	84	46	25	42	76	20	50	33,2	16,8
ZE-35	VWZ-60	15	71	63	40	42	102	20	50	33,2	16,8
ZE-35	VWZ-60V*	10	66	73	42	60	130	30	50	42,9	7,1
ZE-35	VWZ-80*	5	61	84	55	50	130	30	50	42,9	7,1
ZE-50	VWZ-60	17,5	90	63	40	42	102	20	58	33,3	24,7
ZE-50	VWZ-60V	12,5	85	73	42	60	130	30	58	42,9	15,1
ZE-50	VWZ-80*	7,5	80	84	55	50	130	30	58	42,9	15,1
ZE-100	VWZ-60	30	124	63	40	42	102	20	80	33,2	46,8
ZE-100	VWZ-60V	25	119	73	42	60	130	30	80	42,9	37,1
ZE-100	VWZ-80	20	114	84	55	50	130	30	80	42,9	37,1
ZE-150	VWZ-60	30	130	63	40	42	102	20	92,5	33,2	59,3
ZE-150	VWZ-60V	25	125	73	42	60	130	30	92,5	42,9	49,6
ZE-150	VWZ-80	20	120	84	55	50	130	30	92,5	42,9	49,6
ZE-200	VWZ-60	34	146,5	63	40	42	102	20	88	54	34
ZE-200	VWZ-60V	29	141,5	73	42	60	130	30	88	42,9	45,1
ZE-200	VWZ-80	24	136,5	84	55	50	130	30	88	42,9	45,1
ZE-200	VWZ-100	14	126,5	97	65	70	170	50	88	57,2	30,8
Z-250	VWZ-80	24	144	84	55	50	130	30	105	42,9	62,1
Z-250	VWZ-100	14	134	97	65	70	170	50	102	57,2	44,8
Z-350	VWZ-80	35	175	84	55	50	130	30	115	42,9	72,1
Z-350	VWZ-100	25	165	97	65	70	170	50	115	57,3	57,8
Z-500	VWZ-80	75	240	84	55	50	130	30	130	42,9	87,1
Z-500	VWZ-100	65	230	97	65	70	170	50	130	57,2	72,8

\*cannot be fitted with pivot mounts LB

### Ordering example:

**VWZ-60-LA1800-25/20S**

Length

Bore 1st side / 2nd side (S = rigid hub)

n=1500 rpm (specify the speed)

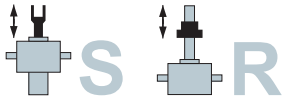

## Pedestal bearing STL

for connecting shaft VWZ

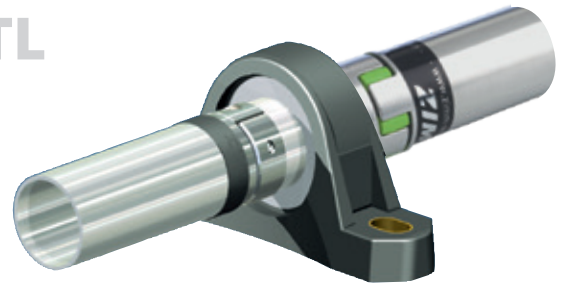
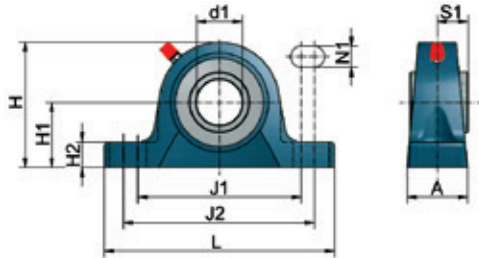

### Technical data

We use high-quality pedestal bearings.

Material:

Housing material: Grey cast iron, primed in blue

Bearing material: Roller bearing steel

Temperature range: -30°C to +120°C

### Pedestal bearing STL

Code	d1	A	H	H1	H2	J1	J2	L	N1	S1	kg
STL-15-G	15	32	56	30,2	14	88	106	127	11,5	15,3	0,47
STL-20-G	20	32	65	33,3	14	88	106	127	11,5	18,3	0,59
STL-30-G	30	40	82,5	42,9	17	108	127	152	14	22,2	1,1
STL-50-G	50	54	114,5	57,2	22	149	165	203	18	32,6	2,7

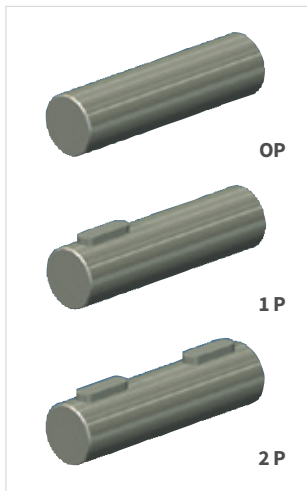

### Shaft extension WZ

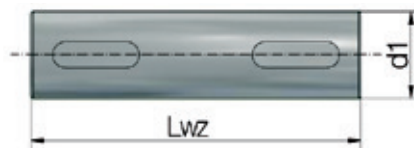

A pedestal bearing is used for long connecting shafts that are operated at higher speeds. Please pay special attention to the installation height of the pedestal bearing.

Code	d1	Lwz	kg
WZ-15/74-?P	15	74	0,1
WZ-20/76-?P	20	76	0,19
WZ-20/102-?P	20	102	0,25
WZ-30/130-?P	30	130	0,72
WZ-50/170-?P	50	170	2,61

### Ordering example:

HR-125-11-N

Diameter: \_\_\_\_\_ ↑  
 Bore: \_\_\_\_\_ ↑  
 N = with keyway and set screw  
 V = only pilot hole \_\_\_\_\_ ↑



## Standard coupling KUZ

Coupling with keyway and set screw

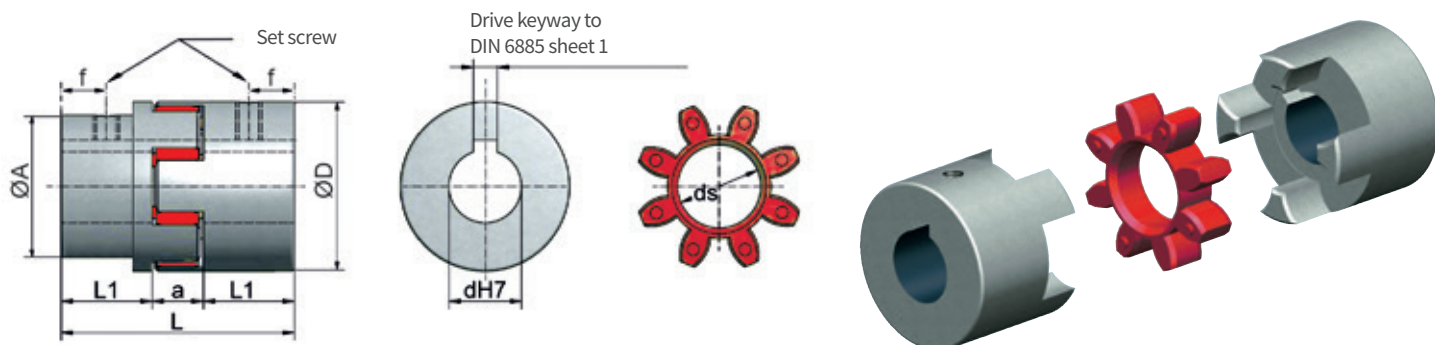

### Dimensions

Size	D	A offset hub	L	L1	a	f	ds star	L1 long hub	Set screw	Tightening torque Nm
KUZ-09	20	-	30	10	10	5	-	-	M4	1,5
KUZ-14	27,5	-	44	16	12	7,8	-	-	M6 (M4)	4,8 (1,5)
KUZ-19	34,5	-	51	19	13	9,6	12	-	M6	4,8
KUZ-24	40	-	66	25	16	10	17	40	M5	2
KUZ-28	55	-	78	30	18	10	26	-	M5	2
KUZ-38	65	-	90	35	20	15	29	60	M6	4,8
KUZ-45	80	66	114	45	24	15	37	-	M8	10
KUZ-55	95	75	126	50	26	20	45	-	M8	10
KUZ-60	105	85	140	56	28	20	50	-	M8	10
KUZ-70	120	98	160	65	30	20	59	-	M10	17
KUZ-75	135	115	185	75	35	20	67	-	M10	17
KUZ-90	160	135	210	85	40	25	79	-	M10	17

### Technical data

Size	Rated torque Nm	max. torque Nm	max. speed rpm	Shore hardness star	Material*	Weight drilled kg	Torsional stiffness $C_{tdyn}$ Nm/rad	Moment of inertia $10^{-3}kgm^2$
KUZ-09	3	6	28000	92A	A	0,05	-	-
KUZ-14	4,5	4,5	20000	55D	S	0,14	254	0,02
KUZ-19	7,3	7,3	14000	55D	S	0,27	274	0,03
KUZ-24	17	34	14000	98A	S	0,34	2920	0,1
KUZ-28	60	120	10600	98A	S	0,9	9930	0,4
KUZ-38	160	320	8500	98A	S	1,5	26770	1,4
KUZ-45	325	650	7100	98A	G	2,35	48570	2,5
KUZ-55	450	900	6000	98A	G	3,55	54500	6,1
KUZ-60	625	1050	5600	98A	G	4,85	65290	10,2
KUZ-70	625	1250	4750	98A	G	7,4	94970	20,3
KUZ-75	900	1300	4250	98A	G	10,8	129510	37,1
KUZ-90	1500	3000	3550	98A	G	17,7	197500	84

\*A = Aluminium, S = Sintered steel, G = Cast iron



# Standard coupling KUZ

## Coupling with keyway and set screw

### Standard bores „d“ mm

KUZ-09:	U, 8, 9
KUZ-14:	U, 9, 11, 14
KUZ-19:	U, 11, 14, 16, 19
KUZ-24:	U, 11, 14, 16, 19, 19L, 20, 24
KUZ-28:	U, 14, 16, 19, 20, 24, 25, 28
KUZ-38:	U, 25, 28, 28L, 32, 38
KUZ-45:	U, 25, 28, 32, 38, 42, 45
KUZ-55:	U, 28A, 38A, 40A, 42A, 48, 55
KUZ-60:	38A, 40A, 60
KUZ-70:	40A, 65

U = not drilled (KUZ-19 pre-drilled  $\varnothing 6,3$  mm)  
 L = long hub  
 A = offset hub  
 \* = coupling with set screw, without keyway.  
 Other diameters available on request.



### Elastomer star

<b>Material:</b>	polyurethane
<b>Damping:</b>	medium to good damping
<b>Strength:</b>	very good long-term strength
<b>Temperature range:</b>	-20°C to +70°C reduced to -30°C, up to +100°C (Mx0,55)

### Coupling with keyway and set screw

<b>Material:</b>	as shown in the table
<b>Keyway:</b>	DIN 6885/1-P9
<b>Other features:</b>	Provides rotational resilience and maintenance-free

### Permissible assembly errors

Size	A mm	R mm	$\beta$
KUZ-09	0,8	0,15	1,0°
KUZ-14	0,75	0,4	0,5°
KUZ-19	0,75	0,4	0,5°
KUZ-24	1,2	0,2	0,9°
KUZ-28	1,4	0,22	0,9°
KUZ-38	1,5	0,25	0,9°
KUZ-45	1,8	0,28	1,0°
KUZ-55	2	0,32	1,0°
KUZ-60	2,1	0,36	1,1°
KUZ-70	2,2	0,38	1,1°
KUZ-75	2,6	0,42	1,2°
KUZ-90	3	0,48	1,2°

### Potential assembly errors (KUZ and KUZ-KK)

Assembly instruction	Axial displacement A	Axis offset R	Angular error $\beta$
<p>Check the angle and radial offset using straight edges in two planes</p>	<p>axial</p>	<p>lateral</p>	<p>angular</p>

### Ordering example:

**KUZ-24-20/24**

Size \_\_\_\_\_  
 Bore 1st side \_\_\_\_\_  
 bore 2nd side \_\_\_\_\_

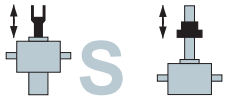

# Clamp coupling KUZ-KK

Coupling with split shells

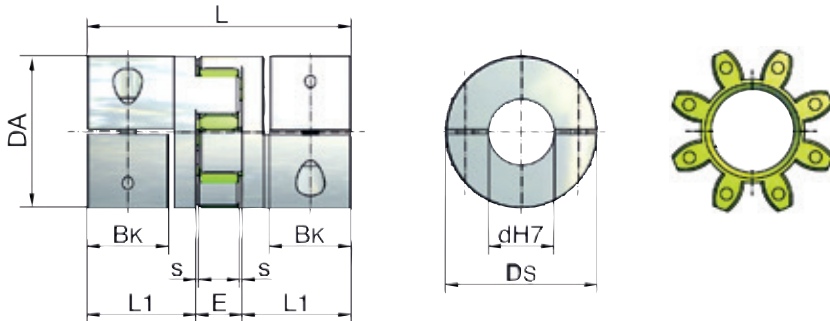

## Dimensions

Size	Dimensions							Clamping screw		Moment of inertia	Torsional stiffness	Weight
	DA mm	DS mm	L mm	L1 mm	BK* mm	s mm	E mm	M 10,9	Tightening torque Nm	$10^{-3}\text{kgm}^2$	$C_{tdyn}$ Nm/rad	kg
KUZ-KK-16	32	32	54	21	15	1,5	12	M4	4	0,01	1375	0,1
KUZ-KK-24	42	44,5	66	25	17	1,5	16	M5	8	0,08	3700	0,2
KUZ-KK-32	56	57	98	40	30	2	18	M6	15	0,24	9917	0,55
KUZ-KK-35	67	68	114	47	35	2	20	M8	35	0,51	24417	0,9
KUZ-KK-45	82	85	134	55	40	2	24	M10	70	2,4	33667	1,6
KUZ-KK-60	102	105	156	65	50	2	26	M12	120	6	67667	2,7

\*BK = shaft extension clamping length

## Technical data

Size	Elastomer star		Maximum transmittable torque of clamp hub depending on the bore diameter (clamp force)																	
	Rated torque Nm	max. torque Nm	Ø9 Nm	Ø11 Nm	Ø14 Nm	Ø16 Nm	Ø19 Nm	Ø20 Nm	Ø22 Nm	Ø24 Nm	Ø25 Nm	Ø28 Nm	Ø30 Nm	Ø32 Nm	Ø38 Nm	Ø40 Nm	Ø42 Nm	Ø45 Nm	Ø48 Nm	Ø55 Nm
KUZ-KK-16	16	32	21	26	33	37														
KUZ-KK-24	21	42	-	41	52	60	70	74	81	89	-	-	-	-	-	-	-	-	-	-
KUZ-KK-32	75	150	-	60	76	87	104	109	120	131	136	153	164	175	-	-	-	-	-	-
KUZ-KK-35	200	400	-	-	-	120	-	188	206	-	235	-	-	301	-	-	-	-	-	-
KUZ-KK-45	405	810	-	-	-	325	386	406	447	488	508	568	610	650	772	-	854	915	-	-
KUZ-KK-60	660	1350	-	-	-	-	-	-	-	-	570	638	-	730	866	914	960	1029	1097	1250

The max. torque is limited either by the star or by the clamping force



# Clamp coupling KUZ-KK

## Coupling with split shells

### Standard bores „d“ mm

KUZ-KK-16:	8, 9, 10, 11, 12, 14, 15, 16
KUZ-KK-24:	9, 10, 11, 12, 14, 15, 16, 18, 19, 20, 22, 24
KUZ-KK-32:	10, 11, 12, 14, 15, 16, 18, 19, 20, 22, 24, 25, 28, 30, 32
KUZ-KK-35:	12, 15, 16, 18, 20, 22, 24, 25, 28, 30, 32, 35
KUZ-KK-45:	16, 19, 20, 22, 24, 25, 28, 30, 32, 35, 38, 40, 42, 45
KUZ-KK-60:	25, 28, 32, 38, 40, 42, 45, 48, 50, 55

Other diameters available on request  
Keyway available on request



### Coupling with split shells

<b>Material:</b>	High-tensile aluminium
<b>Keyway:</b>	None, stepless adjustment facility thanks to the clamp hub rather than a fitted drive key Keyway available on request
<b>Insertion:</b>	Split shells permit easy radial insertion
<b>Other features:</b>	High concentricity High clamping forces Low moment of inertia

### Elastomer star

<b>Material:</b>	Polyurethane
<b>Shore-hardness:</b>	64D
<b>Colour:</b>	ZIMM green
<b>Other features:</b>	Permanently free of play, dampens vibration Temperature range: -20°C to +70°C reduced to -30°C, to +100°C (Mx0,55)

### Permissible assembly errors

Size	A mm	R mm	$\beta$
KUZ-KK-16	$\pm 1$	0,08	1°
KUZ-KK-24	$\pm 2$	0,08	1°
KUZ-KK-32	$\pm 2$	0,1	1°
KUZ-KK-35	$\pm 2$	0,15	1°
KUZ-KK-45	$\pm 2$	0,12	1°
KUZ-KK-60	$\pm 2$	0,14	1°

Figure "Potential assembly errors" see previous page.

### Potential assembly errors (KUZ and KUZ-KK)

Assembly instruction	Axial displacement A	Axis offset R	Angular error $\beta$
<p>Check the angle and radial offset using straight edges in two planes</p>	<p>axial</p>	<p>lateral</p>	<p>angular</p>

### Ordering example:

**KUZ-KK-32-20/24**

Size \_\_\_\_\_  
Bore 1st side \_\_\_\_\_  
Bore 2nd side \_\_\_\_\_

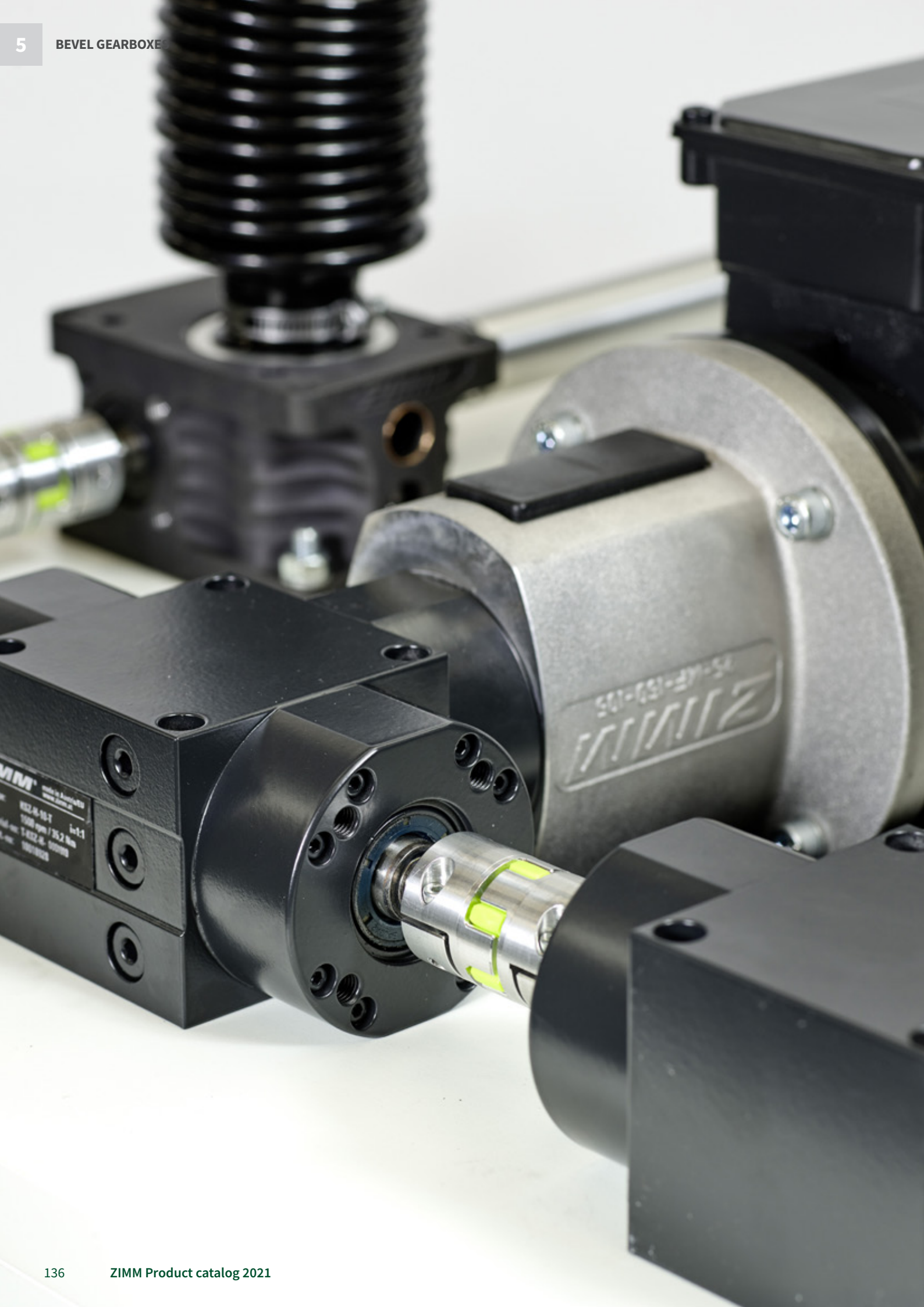



# CHAPTER 5

## Bevel gearboxes

### KSZ-H

#### Bevel gearboxes KSZ-H

Bevel gearboxes KSZ-H, L + T Version, 5 - 150

Dimensions ..... 138

Technical data ..... 139

### Accessories

#### Accessories for KSZ-H

Motor flange combinations for KSZ-H, 5 - 35 ..... 140

Motor flange combinations for KSZ-H, 50 - 150 ..... 141

### KSZ-2

#### Bevel gearboxes KSZ-2 for GSZ-2

see chapter 2 section GSZ

Bolt-on gearbox, layout (Systems) ..... 76

KSZ-2 Bolt-on gearbox, technical data ..... 77

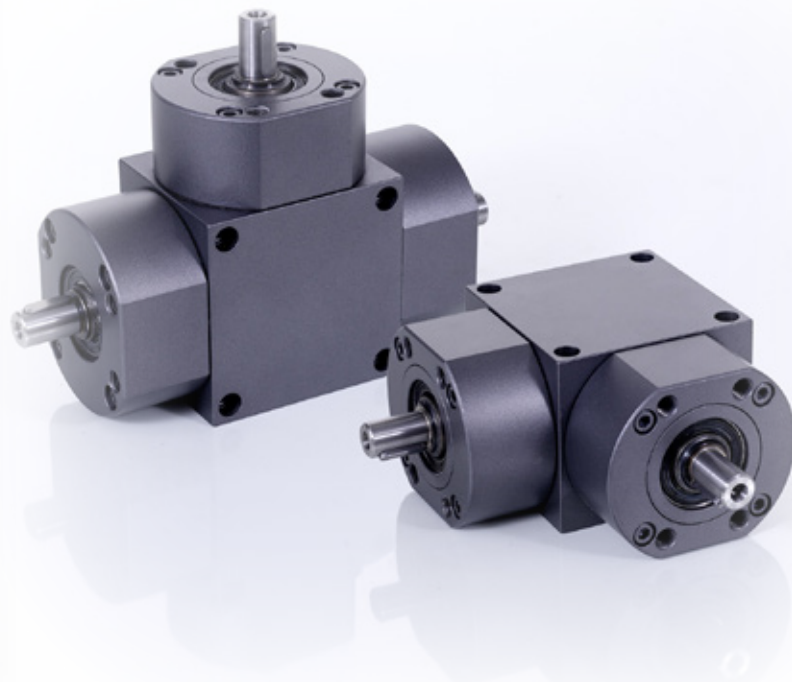

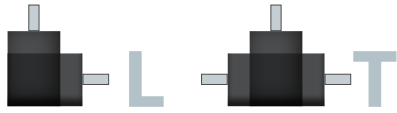

# Bevel gearboxes 5 to 150

## KSZ-H | T + L-Version with spiral-toothed

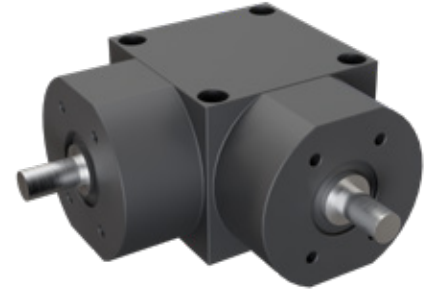
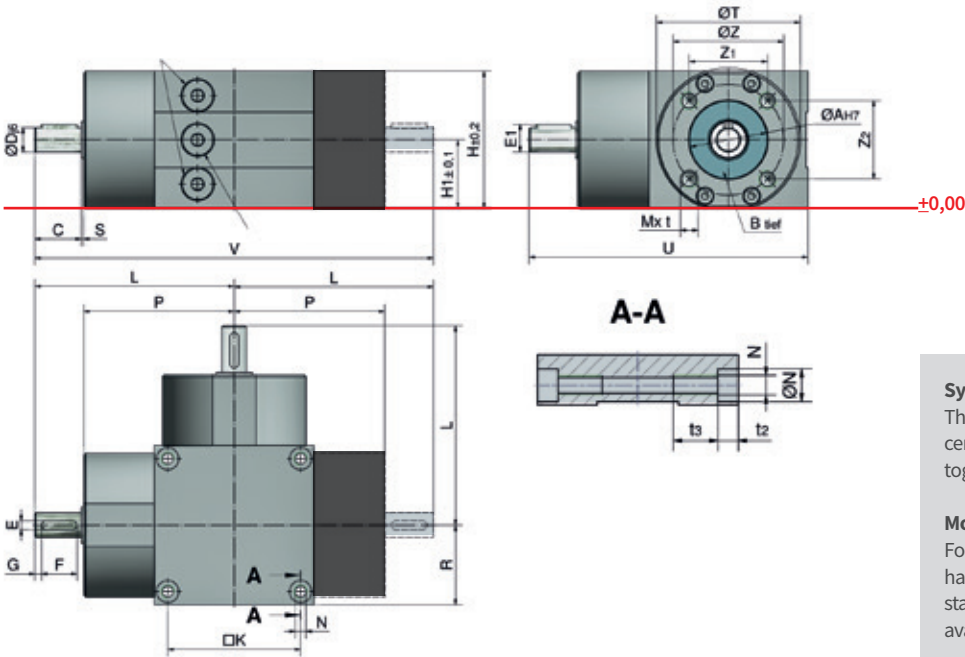

**Symetry**  
The KSZ-H bevel gearboxes can be rotated about the center axis in all directions and can also be bolted together.

**Motor flange & motor mounting**  
For the motor flange, bevel gearboxes and screw jacks have the same hole pattern. There is a wide range of standard IEC motor flanges for easy motor mounting available from ZIMM.

**Dimensions**

Code	ØAH7	B	C	Dj6	Eh9	E1	F	G	H	H1	□K	L	M	t	N	ØN	t2	t3	P	R	S	ØT	U	V	ØZ	Z1	Z2
KSZ-H-5-L/T	35	3	21	11	4	12,5	16	3	62	31	60	90	M8	12	M6	10	6,4	20	68	36	1	65 <sup>1</sup>	126	180	50	35,4	35,4
KSZ-H-10-L/T	40	3	26	14	5	16	20	3	74	37	70	105	M8	12	M8	11	8,2	25	77,5	42,5	1,5	77 <sup>2</sup>	147,5	210	59,4	42	42
KSZ-H-25-L/T	42	3	27	16	5	18	22	3	82	41	78	117	M10	15	M8	11	8,2	25	88,5	47,5	1,5	91 <sup>3</sup>	164,5	234	71,7	62	36
KSZ-H-35-L/T	52	4	34	19	6	21,5	28	3	100	50	98	150	M10	20	M10	15	10,2	30	114	60	2	102 <sup>4</sup>	210	300	86	70	50
KSZ-H-50-L/T	52	4	39	20	6	22,5	32	3	116	58	110	165	M10	20	M12	20	12,6	30	124	67,5	2	126 <sup>5</sup>	232,5	330	86	50	70
KSZ-H-100-L/T	62	4	45	32	10	35	40	3	160	80	154	235	M12	22	M12	20	12,6	35	188	94	2	170 <sup>6</sup>	329	470	106,5	46	96
KSZ-H-150-L/T	62	5	53	38	10	41	50	1,5	185	92,5	180	275	M12	22	M16	26	15,1	40	220	110	2	188 <sup>7</sup>	385	550	106,5	46	96

Material: EN-GJL-200 (GGL-20), corrosion resistant, bolt: stainless steel, sealing by means of shaft seals and O-rings.  
 ØT Flattening: 1) 61 mm 2) 73 mm 3) 80 mm 4) 99 mm 5) 115 mm 6) 159 mm 7) 184 mm

**Same mounting height – no support plates required**

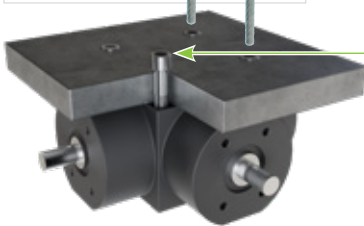
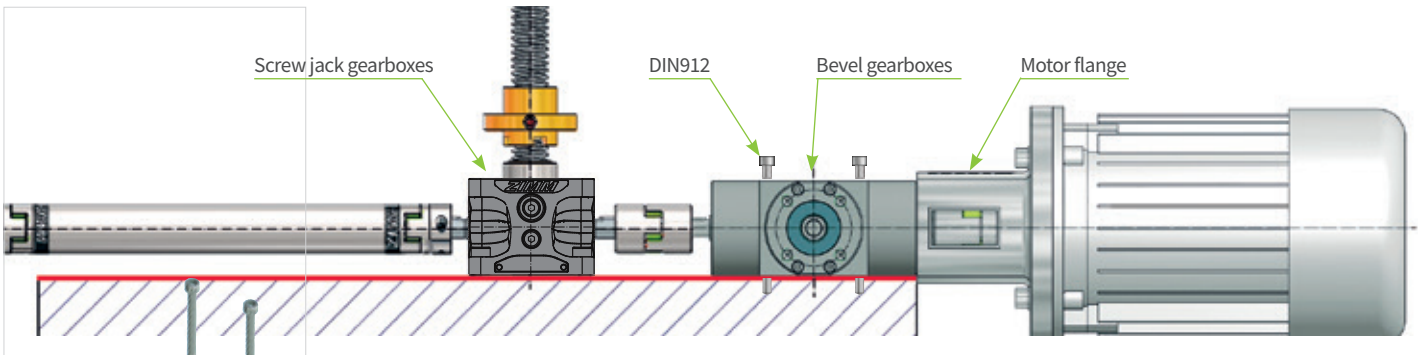

**Additional attachment options**  
Besides the standard internal threads for screw connection from below, the special design of the bores now also permits screw connection from above.  
 DIN 912 hexagon socket head screws can be used.  
 A wide selection of standard IEC motor flanges of the ZIMM screw jacks are available to ensure simple motor mounting.

**Same mounting height as the screw jacks in the same size**  
 The ZIMM bevel gearboxes KSZ-H have the same fitting height as the ZIMM screw jack gearbox. No support plates are required. Furthermore, they are dimensionally compatible with the previous KSZ and KGZ types.  
 If a larger bevel gearbox has to be used due to a high torque, the difference in height must be compensated structurally by means of shims or similar.

# Technical data

## Quality features & advantages of the KSZ-H series

Features of the KSZ-H bevel gearhead series include high precision and torque, and a high-quality two-component paint finish that provides effective corrosion protection. For easy motor mounting, the large selection of standard IEC motor flanges of the ZIMM screw jacks is available.

- + Low-backlash version
- + Quiet running
- + High torque transmission in a small size
- + Pre-loaded taper roller bearings
- + Sealing by means of shaft seals and O-rings
- + Permanent lubrication with oil; oil change required only on heavy duty applications

## Technical data overview

- Housing material:** EN-GJL-200 (GGL 20), corrosion resistant
- Bevel gears:** Spiral-toothed
- Installation axis/Dimensions:** All-sided, symmetrical with screw jack mounting position any, or in all directions possible.
- Duty factor:** Max. 40% at 1500 min<sup>-1</sup>
- Drive ratio:** 1:1, 2:1, 3:1
- Temperature range:** -10C to +90C

## Instruction on the direction of rotation of the shaft configuration

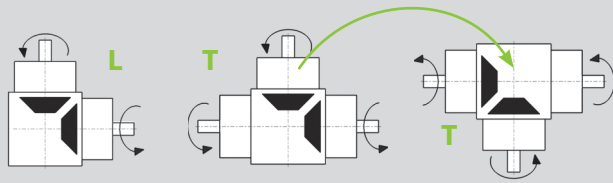

### Direction of rotation

To change the direction of rotation, the bevel gearboxes can be rotated by 180°. Since the gears are symmetrical, it can be rotated around the Z-axis as well as on the Y-axis.

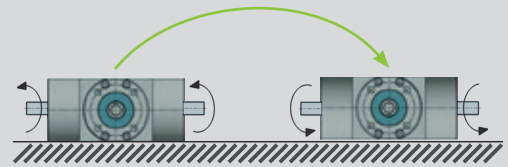

### When rotating around Y axis

by 180°, the direction of rotation changes.

## Technical data

Screw jacks	i	Permissible torque Nm at various speeds rpm					Moment of inertia kg cm <sup>2</sup>		F radial N	Weight kg	
		100	500	1000	1500	3000	L	T		L	T
KSZ-H-5-L/T	1:1	21	19,8	19,8	19,8	17	0,614	0,748	140	3,1	3,7
	2:1	14	13,7	13,7	13,5	13,2	0,614	0,748	140	3,1	3,7
	3:1	10	10	10	10	10	0,614	0,748	140	3,1	3,7
KSZ-H-10-L/T	1:1	44,4	41,9	40,2	35,2	28,7	1,855	2,422	200	4,8	6
	2:1	27,5	27,2	27	26,7	26	1,855	2,422	200	4,8	6
	3:1	20,1	20	20	19,9	19,7	1,855	2,422	200	4,8	6
KSZ-H-25-L/T	1:1	72	71	60	52,5	42	3,38	4,215	300	7,2	9,1
	2:1	41	40	40	40	38	3,38	4,215	300	7,2	9,1
	3:1	34	34	33,5	33,5	33	3,38	4,215	300	7,2	9,1
KSZ-H-35-L/T	1:1	162	160	155	135	110	11,055	14,055	550	10,6	14,1
	2:1	78	77	76	74	70	11,055	14,055	550	10,6	14,1
	3:1	51	51	50,5	50	49	11,055	14,055	550	10,6	14,1
KSZ-H-50-L/T	1:1	162	160	158	155	125	11,586	16,269	1100	17	21,4
	2:1	145	144	143	141	115	11,586	16,269	1100	17	21,4
	3:1	100	100	99	98	93	11,586	16,269	1100	17	21,4
KSZ-H-100-L/T	1:1	507	466	455,5	450,5	370	107,8	126,074	1600	54	70,6
	2:1	410	410	400	400	320	107,8	126,074	1600	54	70,6
	3:1	315	315	313	311	305	107,8	126,074	1600	54	70,6
KSZ-H-150-L/T	1:1	781	719,4	703,6	680	540	206,407	236,908	2500	82,1	103
	2:1	675	670	664	657	555	206,407	236,908	2500	82,1	103
	3:1	500	497	494	490	435	206,407	236,908	2500	82,1	103

### Ordering example:

**KSZ-H-50-T-1:1**

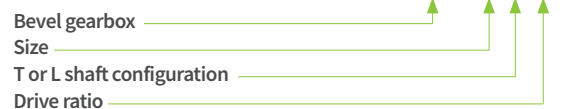

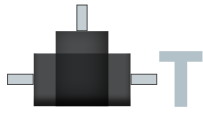
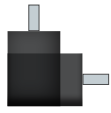

# Bevel gearbox accessories

## Motor flange combinations | KSZ-H-5 to KSZ-H-35

Motor flange MF  
KSZ-H-5 to KSZ-H-25

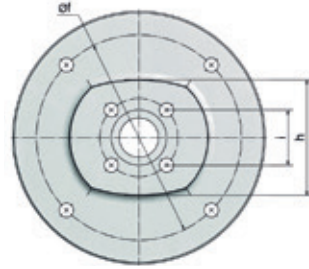
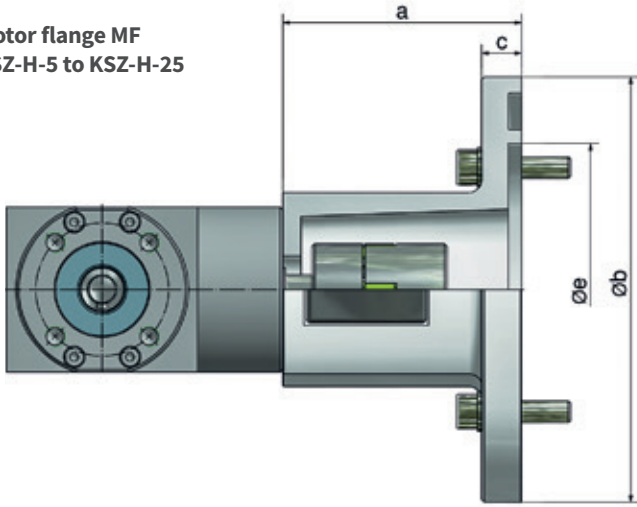

Motor flange MF  
KSZ-H-35

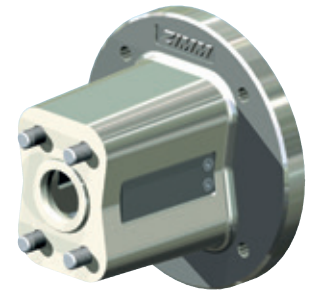
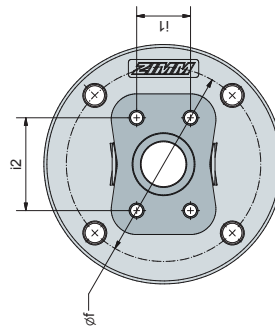
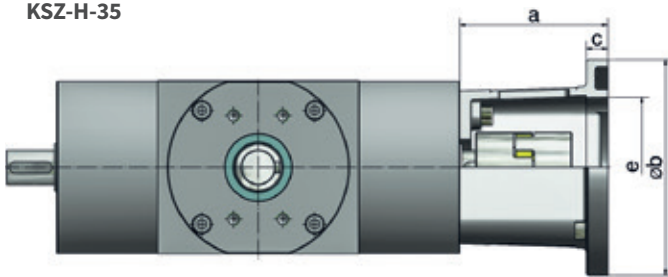

Size	Code	Motor-Type	Coupling Code		4 of Screws gearbox side 8,8 DIN *	4 of socket head cap screws 8.8 DIN 912	a	b	c	e	f	h/ i1	i/ i2	kg	Transmittable torque Nm <sup>3)</sup>			
			Bore - Ø	Size											Gearbox	Motor	Rated.	max.
KSZ-H-5	ZE-10-MF-120-66	63 B14B	KUZ-19	11	11	M8x16	M6x20 <sup>1)</sup>	66	120	10	80	100	73	35,4	0,4	6,1	6,1	
KSZ-H-5	ZE-10-MF-160-75	71 B5	KUZ-19	11	14	M8x16	M8x35 <sup>2)</sup>	75	160	15	110	130	73	35,4	0,8	5,5	5,5	
KSZ-H-5	ZE-10-MF-160-90	80 B14B	KUZ-24	11	19	M8x16	M8x30 <sup>1)</sup>	90	160	15	110	130	73	35,4	0,8	13,4	13,4	
KSZ-H-10	ZE-25-MF-160-105	71 B5	KUZ-28	14	14	M8x20	M8x35 <sup>2)</sup>	105	160	15	110	130	81	42	1,1	22,7	22,7	
KSZ-H-10	ZE-25-MF-160-105	80 B14B	KUZ-28	14	19	M8x20	M8x30 <sup>1)</sup>	105	160	15	110	130	81	42	1,1	27,7	27,7	
KSZ-H-10	ZE-25-MF-160-105	90 B14B	KUZ-24	14	24	M8x20	M8x30 <sup>1)</sup>	105	160	15	110	130	81	42	1,1	17	27,7	
KSZ-H-10	ZE-25-MF-160-122	100 B14C	KUZ-28	14	28	M8x20	M8x30 <sup>1)</sup>	122	160	15	110	130	81	42	1,2	27,7	27,7	
KSZ-H-25	ZE-35-MF-160-111	80 B14B	KUZ-24	16	19L	M10x30	M8x25 <sup>1)</sup>	111	160	15	110	130	36	62	2,7	17	34	
KSZ-H-25	ZE-35-MF-160-111	90 B14B	KUZ-24	16	24	M10x30	M8x25 <sup>1)</sup>	111	160	15	110	130	36	62	2,7	17	25,9	
KSZ-H-25	ZE-35-MF-B + ZE-35-MF-P-200	100 B14B	KUZ-28	16	28	M10x120	M10x30 <sup>1)</sup>	123	200	12	130	165	36	62	3,6	25,9	25,9	
KSZ-H-25	ZE-35-MF-B + ZE-35-MF-P-200	112 B14B	KUZ-28	16	28	M10x120	M10x30 <sup>1)</sup>	123	200	12	130	165	36	62	3,6	25,9	25,9	
KSZ-H-25	ZE-35-MF-B + special plate	Servomotors, geared motors, Nema, ...																
KSZ-H-35	ZE-50-MF-200-116	90 B5	KUZ-28	19	24	M10x30	M10x45 <sup>2)</sup>	116	200	20	130	165	50	70	4,1	60	72,7	
KSZ-H-35	ZE-50-MF-200-126	100 B14B	KUZ-28	19	28	M10x30	M10x35 <sup>1)</sup>	126	200	20	130	165	50	70	4,3	60	72,7	
KSZ-H-35	ZE-50-MF-200-126	112 B14B	KUZ-28	19	28	M10x30	M10x35 <sup>1)</sup>	126	200	20	130	165	50	70	4,3	60	72,7	

Material: Aluminium, all screws galvanized nut DIN 934  
 \*Screws DIN 7991 in size 5 - 10!  
 From KSZ-H-25 are screws in DIN 912.

and spring washers DIN 128. Delivery incl. screws.  
 1) incl. spring washers  
 2) inkl. nuts

3) is only valid for this combination. CAUTION: Permissible torque of the respective KSZ-H must be observed.

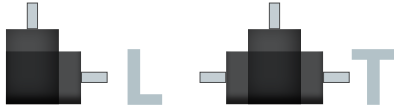

# Bevel gearbox accessories

## Motor flange combinations | KSZ-H-50 to KSZ-H-150

Motor flange base MF-B and motor flange plate MF-P - KSZ-H-50 to KSZ-H-150 (2 pieces)

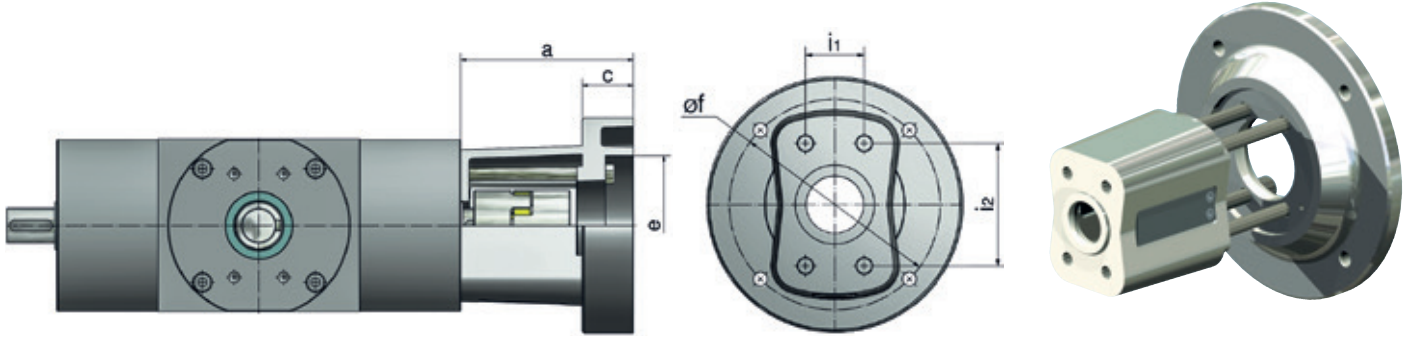

Size KSZ-H	Code	Motor Type	Coupling Code Bore - Ø			4 of screws gearbox side DIN 912	4 of screws motor side DIN 912	a	b	c	e	f	i1	i2	kg	Transmittable torque Nm <sup>4)</sup>	
			Size	Gearbox	Motor											Rated.	max.
KSZ-H-50	ZE-50-MF-200-116	90 B5	KUZ-28	20	24	M10x30	M10x45 <sup>1)</sup>	116	200	20	130	165	50	70	4,1	60	118
KSZ-H-50	ZE-50-MF-200-116	100 B14B	KUZ-28	20	28	M10x30	M10x35 <sup>1)</sup>	126	200	20	130	165	50	70	4,3	60	118
KSZ-H-50	ZE-50-MF-200-126	112 B14B	KUZ-28	20	28	M10x30	M10x35 <sup>1)</sup>	126	200	20	130	165	50	70	4,3	60	118
KSZ-H-50	ZE-50-MF-B + special plate	Servomotors, geared motors, Nema, ...															
KSZ-H-100	ZE-100/150-MF-200-138	100 B14B	KUZ-38	32	28	M12x40 <sup>3)</sup>	M10x35 <sup>1)</sup>	138 <sup>3)</sup>	200	20	130	165	46	96	5,2	160	164
KSZ-H-100	ZE-100/150-MF-200-138	112 B14B	KUZ-38	32	28	M12x40 <sup>3)</sup>	M10x35 <sup>1)</sup>	138 <sup>3)</sup>	200	20	130	165	46	96	5,2	160	164
KSZ-H-100	ZE-100/150-MF-B + P-200	132 B14C	KUZ-38	32	38	M12x150 <sup>3)</sup>	M10x65 <sup>1)</sup>	161 <sup>3)</sup>	200	48	130	165	46	96	8,7	160	164
KSZ-H-100	ZE-100/150-MF-B + special plate	Servomotors, geared motors, Nema, ...															
KSZ-H-150	ZE-100/150-MF-200-138	100 B14B	KUZ-38	38	28	M12x40 <sup>3)</sup>	M10x35 <sup>1)</sup>	138 <sup>3)</sup>	200	20	130	165	46	96	5,2	160	266
KSZ-H-150	ZE-100/150-MF-200-138	112 B14B	KUZ-38	38	28	M12x40 <sup>3)</sup>	M10x35 <sup>1)</sup>	138 <sup>3)</sup>	200	20	130	165	46	96	5,2	160	266
KSZ-H-150	ZE-100/150-MF-B + P-200	132 B14C	KUZ-38	38	38	M12x150 <sup>3)</sup>	M10x65 <sup>1)</sup>	161 <sup>3)</sup>	200	48	130	165	46	96	8,7	160	246

Material: GGG-50, corrosion-resistant, all screws galvanized nut DIN 934 and spring washers DIN 128, Delivery incl. screws.

- 1) incl. spring washers
- 2) incl. nuts and spring washers
- 3) Threaded bolt 8.8 with nuts and spring washers

4) is only valid for this combination. CAUTION: Permissible torque of the respective KSZ-H must be observed.



# CHAPTER 6

## Technical information

### Gearbox lubrication & Lubricants

Innovative separate lubrication	144
Lubricants for screw and gearbox	145

### Enquiries

Checklists (Sheet 1 - 2), System layouts	146
Checklists (Sheet 3 - 4), System layouts	148
Checklists (Sheet 5)	
List of components S-Version	150
List of components R-Version	151

### Technical data

Design advice	152
Procedure of specification	155
Fixing	156
Permissible loads, fixed	158
Permissible loads, pivoting	160
Critical buckling force of the screw	162
Critical whirling speed for R gearboxes	163
Determining the drive torque [MG] of a single screw jack	164
Maximum torques	165
Drive torque for screw jacks	
– approximate calculation	166
– precise calculation	167
Maximum forces / torques	168
Length calculation – screw and protective tube	169
Operational reliability and safety	170
Ordering code	171
Temperature	172
Application range	
Clean room, food industry, resistant against corrosion	173

# Innovative separate lubrication

## Lubricants for screw and gearbox

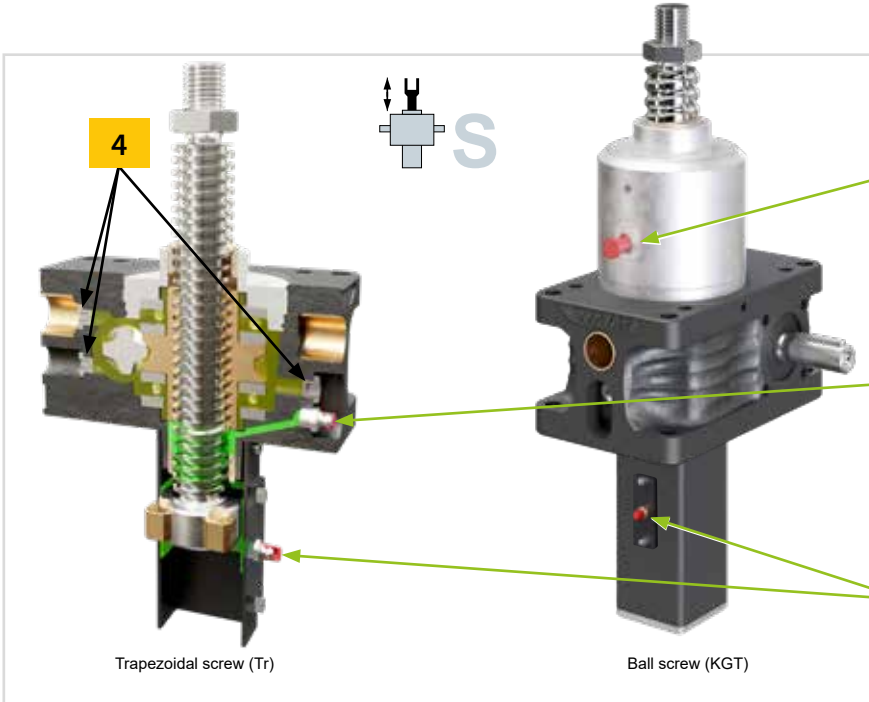

### Screw lubrication during operation provides optimum grease distribution

**1 Ball screw KGT**

Lubricate the ball screw KGT every 300 hours of effective operation. For heavy-duty systems every 100 hours.  
**Grease quantity:**  
 Guidance value approx. 1 ml per cm screw diameter.

**Trapezoidal screw Tr**

**2** Inspect the trapezoidal screw regularly and regrease it depending on the operating cycle. Use the grease that we recommend. These greases are ideally matched to the operating requirements of our screw jack systems.

**Rotation protection VS**

**3** The rotation protection features sliding blocks made of bronze. These can be lubricated by using grease nipples on the protective tube during operation.

Trapezoidal screw (Tr)

Ball screw (KGT)

### Screw lubrication during operation possible

Engineered by the ZIMM R&D team, for optimum grease distribution. For trapezoid threaded screws and ball screws.

### Gearbox lubrication

**4** The gearbox is sealed and is filled with highperformance synthetic grease or oil. The gearbox is lubricated for life in normal operation.

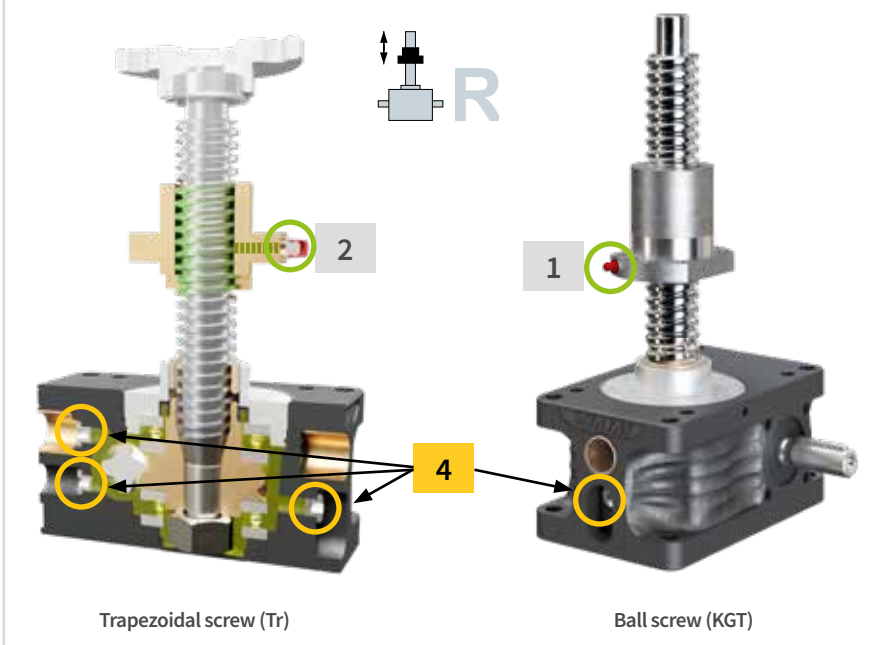

Trapezoidal screw (Tr)

Ball screw (KGT)

### Note

At operating temperatures up to 70 °C, the best lubrication properties are usually achieved with the standard greases. Depending on the ambient temperature, load and duty cycle, the grease becomes too fluid for good lubrication. Especially with trapezoidal thread spindles, high temperatures are reached quickly. Therefore, high-temperature and high-performance greases must be used. We are at your service to advise you on your application.

**WARNING:** Higher idle and breakaway torques are generally to be expected at low temperatures. Synthetic fats are much more suitable than mineral fats here.

### Lubrication for short stroke applications

**S-Version:** For short stroke applications (stroke < gearbox height), take particular care to ensure lubrication of the trapezoidal screw. The simplest tactic is to specify the screw jack with a longer stroke than the gearbox height, and periodically perform a lubrication stroke. Otherwise, contact our Engineering Department for a suitable solution.

**R-Version:** If stroke length < nut height, use a nut with lubrication capability (such as a duplex nut DM).

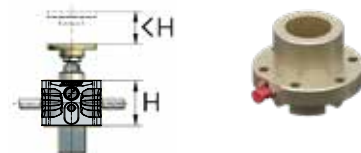

### Long-life systems

The grease used in long-life systems (such as working platforms and theatre stages) loses its lubricating properties after about 5 years. Dust and dirt penetration intensify this effect. We recommend complete cleaning and regreasing after 5 years. If mineral greases are used, this may be necessary after only 2-3 years.



# Lubrication

Recommended, tested lubrications for most favorable life-span

Tr	Trapezoidal screw Tr		Lubricant-Type		Suitability	
	Application	Grease	Appropriate	Conditional/ not appropriate		
	Standard grease up to size 200kN	Tribol GR 4020/460-2 PD	best properties in normal conditions and temperatures		very rigid at low temperatures	
	Standard grease from size 250kN	Tribol GR 3020/1000-2 PD	higher loads, slow speeds from size 250 kN		very rigid at low temperatures	
	High performance grease up to 100°C	Tribol GR 4747/220-2	at increased temperature		cost effective	
	High performance grease up to 150°C	Braycote 2115-2	long lifetime at high continuous temperature, cleanroom, vacuum and food processing		high price	
	Low temperature grease	Tribol GR 4747/220-2	optimum properties and smooth at low temperatures			
	Food grade grease	Tungaloy CP-2/200	approved for food industry, NSF-H1			
	Spindel grease ZE-H series	Tungaloy BS	for high operating cycles or higher loads			

KGT	Ball screw KGT		Lubricant-Type		Suitability	
	Application	Grease	Appropriate	Conditional/ not appropriate		
	Standard grease for KGT	Tribol GR 4747/220-2HT	high quality, synthetic grease for all standard applications			
	Food grade grease	Tungaloy CP-2/200	approved for food industry, NSF-H1			

Getriebe-Fließfett (ZE, Z + GSZ)	Fett-Type		Eignung	
	Application	Grease	Appropriate	Conditional/ not appropriate
	Standard grease gearbox, food grade grease	Optileb GR UF 00	very high quality, synthetic grease for all standard applications with NSF-H1-approval	
	Heavy-duty grease from 250 and ZE-H	Tevier PG Oil	high loads, low speeds, Z-250 to Z-1000	
	High temperature grease up to 150°C	Braycote 2115-0	Long lifetime at high continuous temperatures, cleanroom, vacuum and food	high price

For special applications and for the earlier gearboxes we can offer suitable lubricants in each case.

### Other greases, contamination

Using multipurpose greases and other greases can significantly impair operation and shorten the service life. If the screw becomes dirty, clean and regrease it.



### Lubricants Z-LUB & KART

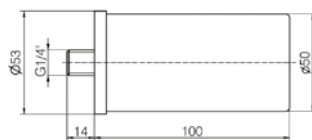

Code	Description	Grease	Quantity mL
Z-LUB	ZIMM-Lubricator incl. reducer	see table	250, *125, 60, 30, *15
KART	Standard spindle grease cartridge	see table	400g

\*In stock, other sizes available on request.

The ZIMM lubricator Z-LUB continuously supplies the screw with lubricant. The Z-LUB is activated when the run-time is set (1 to 12 months at 20°C) (gas generation cell). The filling level can be viewed all the time in the transparent housing.

All spindle greases are available in cartridges 400g.

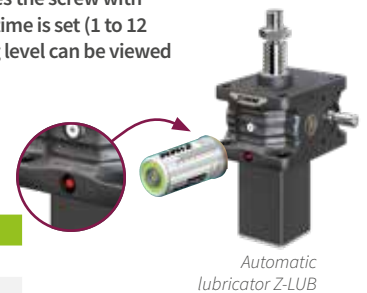

Automatic lubricator Z-LUB

**Ordering example: Z-LUB-125-/Tribol GR 4020/460-2 PD**

Quantity: 125mL

Filling:

# Enquiries

## Checklists | Sheet 1 - Parameter

Company:	_____	Date:	_____
Address:	_____	Phone:	_____
Contact:	_____	E-Mail:	_____
Dept.:	_____	Web:	_____

### 1. max. lifting force in kN

- per gearbox \_\_\_\_\_ kN    entire system \_\_\_\_\_ kN  
 - in tension \_\_\_\_\_ kN    in compression \_\_\_\_\_ kN  
 - Load: static \_\_\_\_\_ kN    dynamic \_\_\_\_\_ kN

### Installation axis

vertical     horizontal     pivoting

### Type of load

smooth     impact loads     vibration

### 2. max. lift/travel \_\_\_\_\_ mm    effective working stroke \_\_\_\_\_ mm

For short stroke applications

(eff. working stroke < gearbox height):  regular lubrication stroke practical     not practical

### 3. Lifting speed

Type N= 25 mm/s (1,5 m/min)     Type L=6,25 mm/s (0,375m/min)     \_\_\_\_\_ mm/s

### 4. Duty factor, work cycle, description of cycle

\_\_\_\_\_ strokes per hour    \_\_\_\_\_ strokes per day    Hours per day:  8     16     24

**i** For high duty factors or long strokes, please provide an exact detailed description on page 123 - 4a

### 5. Type    S „Translating screw“    R „Rotating screw“

### 6. Version    ZE-Screw jack    GSZ-Screw jack

### 7. Motor    Three-phase AC motor    With brake    Manual release    \_\_\_\_\_

### 8. Operating conditions    Dry    Humid    Dust    Chipping    \_\_\_\_\_

Guided movement     No guides (no dyn. lateral forces)

Ambient temperature:    min. \_\_\_\_\_ °C    max. \_\_\_\_\_ °C    (when <10°C and >40°C)

**i** If possible please provide an exact description or sketch on page 123 - 7a

### 9. Standard layouts no.: \_\_\_\_\_    Size: MA1 \_\_\_\_\_    MA2 \_\_\_\_\_    MA3 \_\_\_\_\_    MA4 \_\_\_\_\_    MA5 \_\_\_\_\_

see standard layouts, checklists sheets 5 and 6 (for multi-jack systems)

### 10. Quantity Required \_\_\_\_\_    Series \_\_\_\_\_

### 11. Schedule Quotation \_\_\_\_\_    Delivery \_\_\_\_\_



# Enquiries

## Checklists | Sheet 3 - System layouts

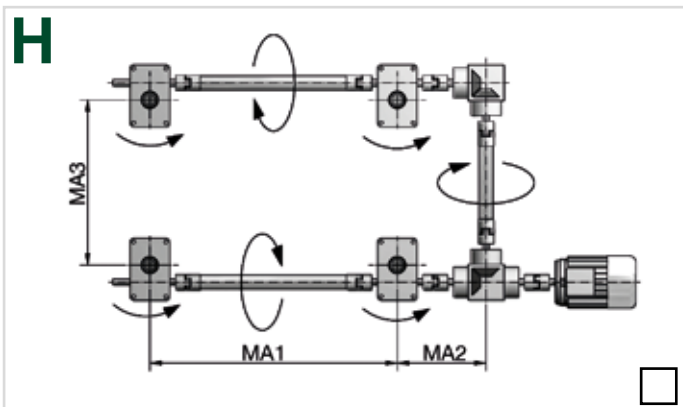
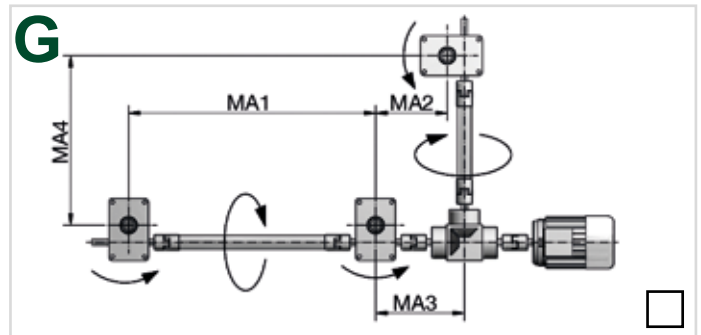
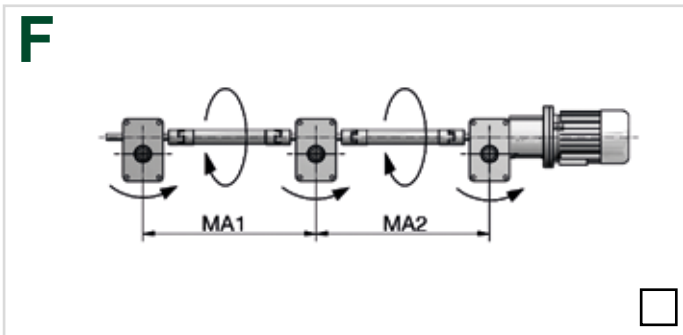
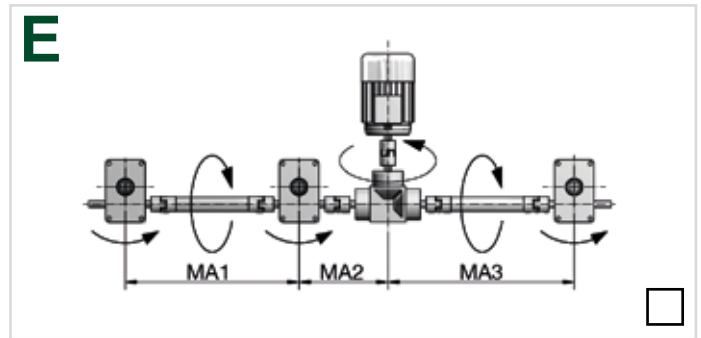
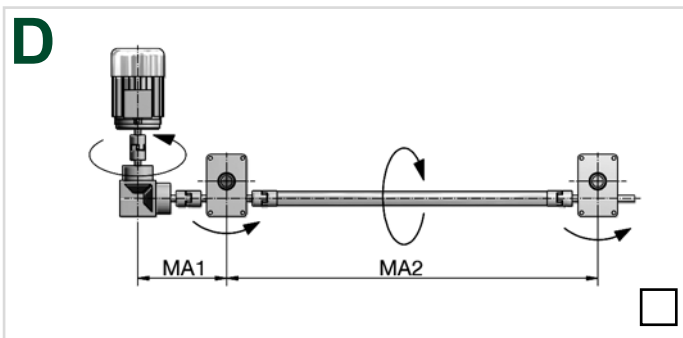
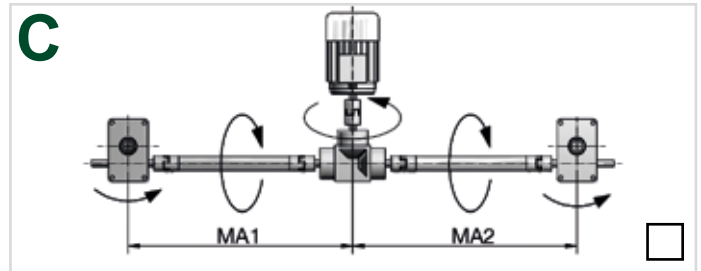
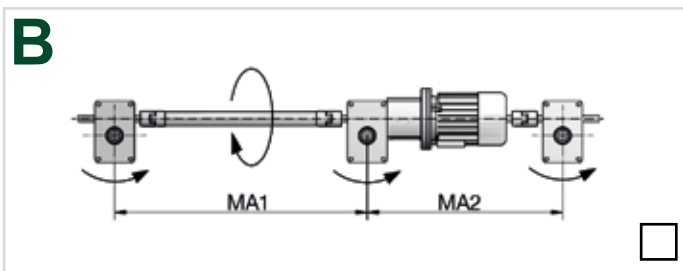
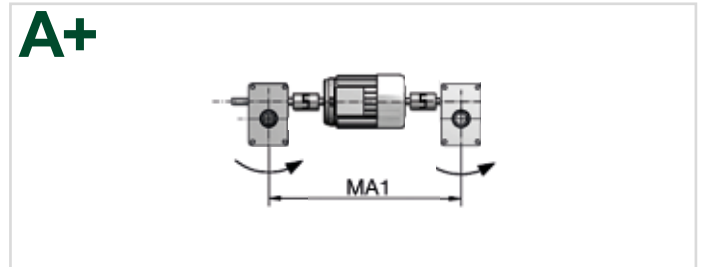
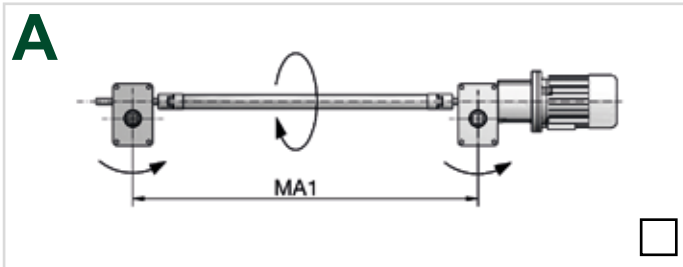

The most common layouts are shown.  
If your design is different, be sure to check the direction of rotation.

# Enquiries

## Checklists | Sheet 4 - System layouts

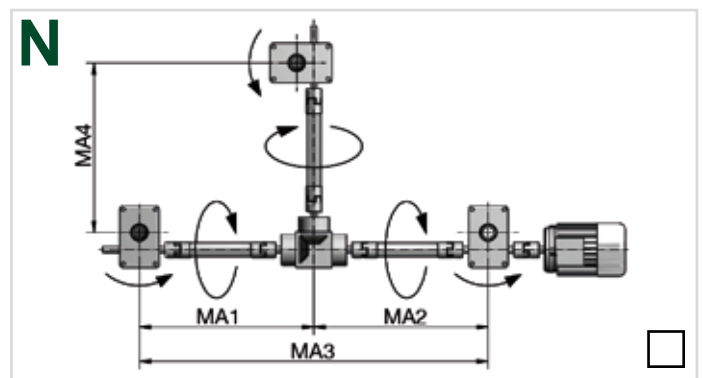
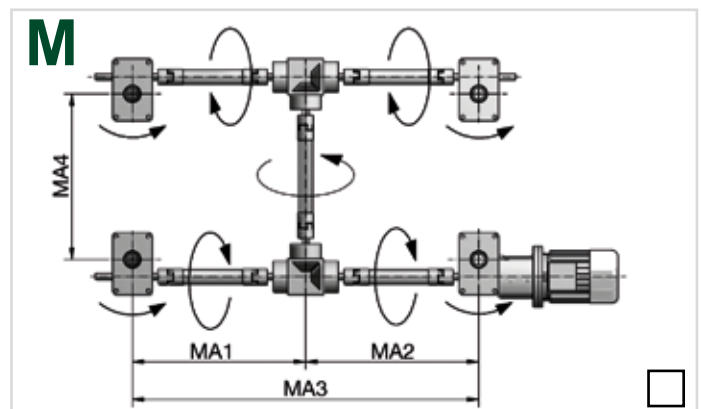
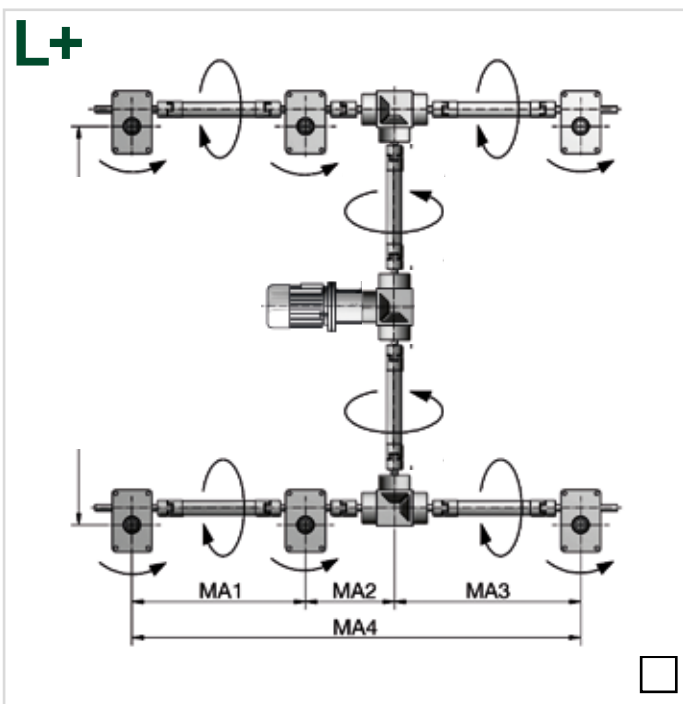
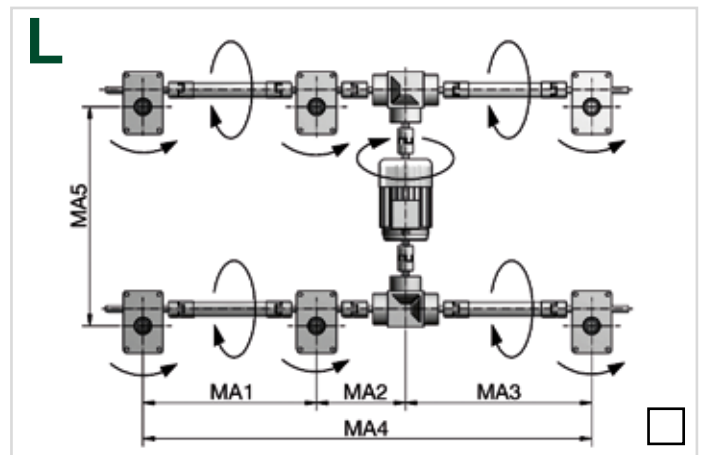
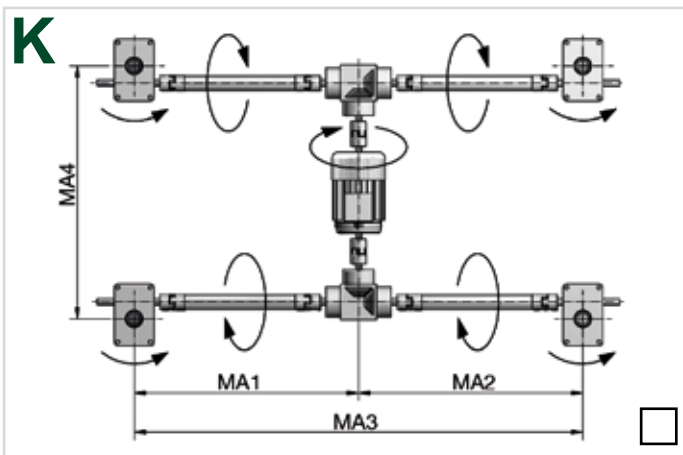
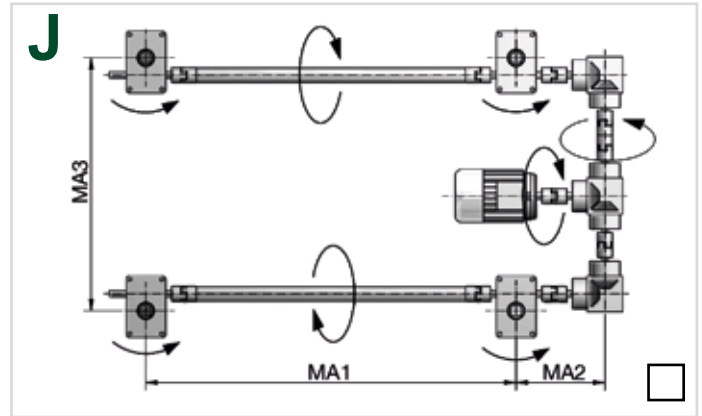
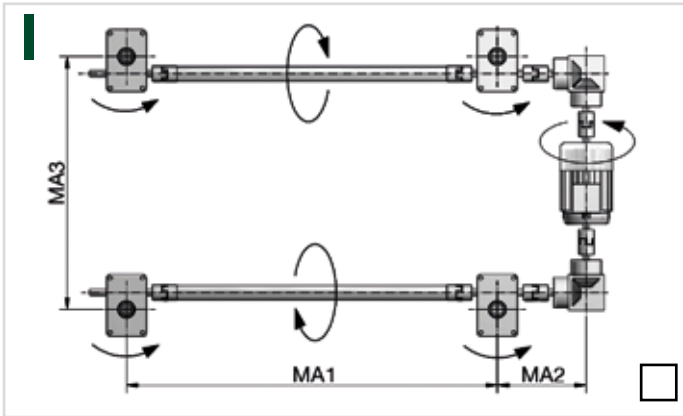

The most common layouts are shown.  
If your design is different, be sure to check the direction of rotation.



# Enquiries

## Checklists | Sheet 5 - List of components S

### Type:

- SN (translating screw, normal)  
 SL (translating screw, low speed)

### Variant:

- Tr Screw  
 SIFA Safety nut  
 with SIFA monitoring  
 KGT Ball screw

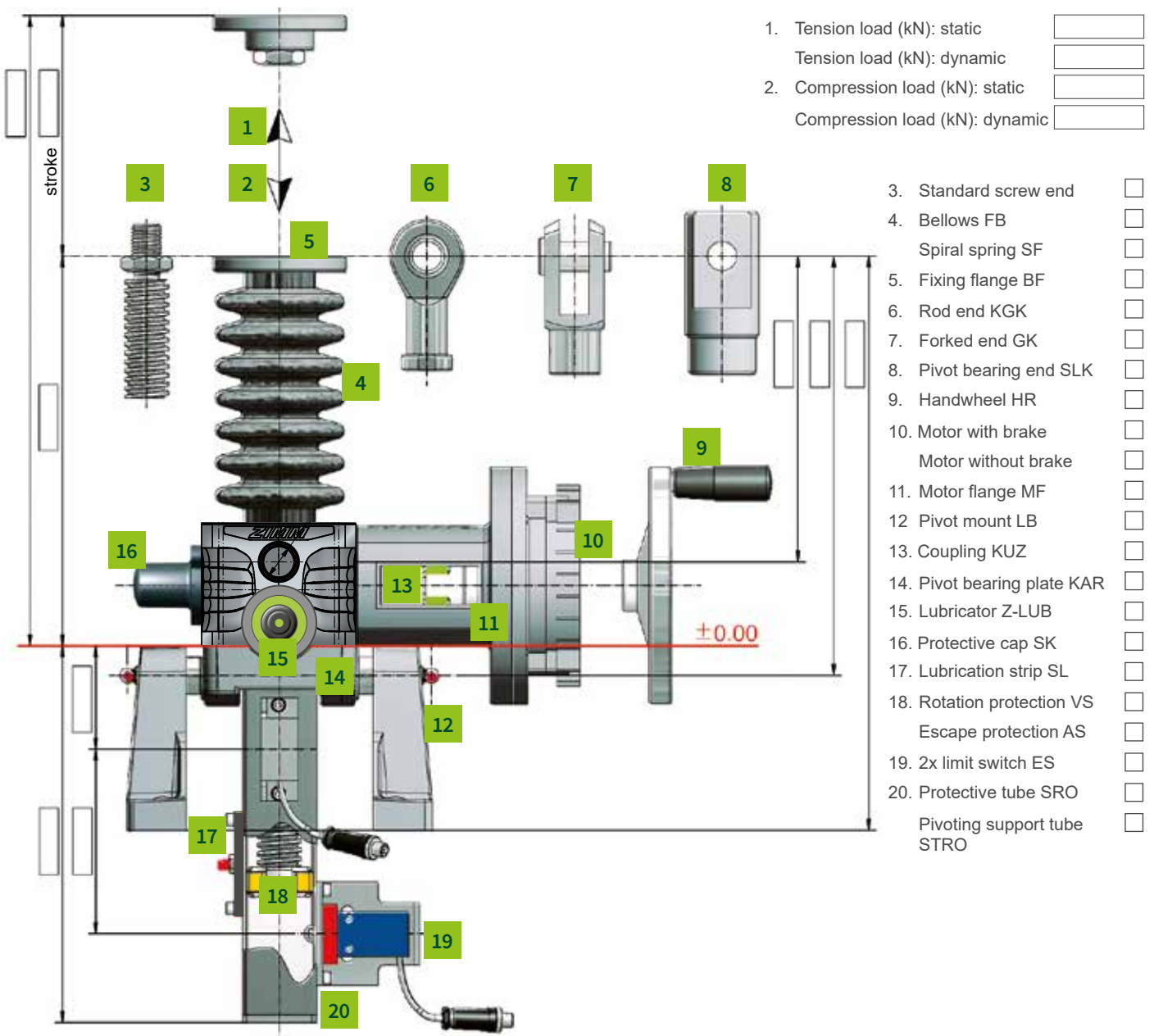

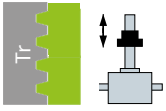

# Enquiries

## Checklists | Sheet 6 - List of components R

**Type:**

- RN (rotating screw, normal)
- RL (rotating screw, low speed)

**Variant:**

- Tr Screw
- SIFA Safety nut
  - with SIFA monitoring
- KGT Ball screw

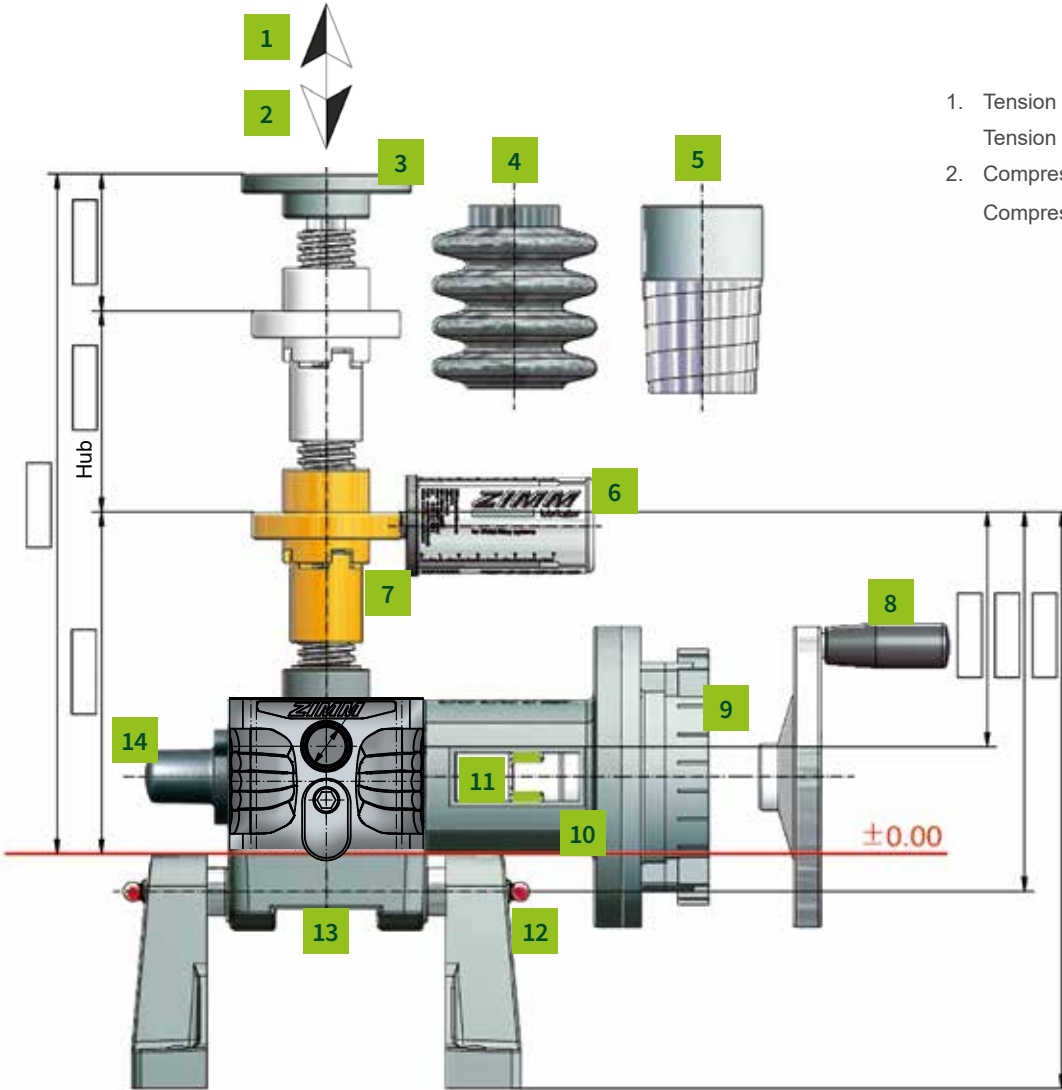

- 1. Tension load (kN): static
- Tension load (kN): dynamic
- 2. Compression load (kN): static
- Compression load (kN): dynamic

- 3. Opposed bearing plate GLP
- 4. Bellows FB
- 5. Spiral spring cover SF
- 6. Lubricator Z-LUB
- 7. Duplex nut DM
- Tr Flange nut FM
- Cardan adapter DMA
- KGT Flange nut KGT-F
- Self-aligning nut PM
- Greaseless nut FFDM
- Driving flange TRMFL
- Safety nut SIFA
- Wear monitoring - SIFA Control
- 8. Handwheel HR
- 9. Motor with brake
- Motor without brake
- 10. Motor flange MF
- 11. Coupling KUZ
- 12. Pivot mounts LB
- 13. Pivot bearing plat KAR
- 14. Protective cap SK



# Design advice

## Design and specification

Selection and dimensioning is the customer's responsibility, because we are not familiar with the design criteria such as installation location and type of application. On request we can provide support during selection and specification and make proposals with subassembly drawings and calculations based on your application parameters. You can then examine and approve these drawings and their parts lists. These then serve as basis for production and preassembly and assist your employees during installation and fitting. We guarantee the quality of the machine elements as described in the catalogue. The gearboxes are designed for industrial use at the loads and duty cycles specified in the catalogue.

If your requirements are not covered by our catalogue descriptions, please contact our project technicians. We generally deliver according to our current Terms of Sales and Delivery (General terms and conditions).

m/min

Lifting speed v:

$$= \frac{\text{Screw pitch } P}{\text{Gear ratio } i} \times \text{motor speed } n$$

## Lifting speed

There are several parameters which affect the lifting speed:

### Faster:

- double-pitch screw (not generally held in stock): This doubles the lifting speed (**CAUTION:** max. input torque, not self-locking - brake required!)
- increased screw for the R version (next larger size of gearbox): depending on the screw jack size, this will give a somewhat greater pitch / lifting speed
- Ball screw: Various pitches are available (**CAUTION:** not self-locking - brake required!)
- Frequency converter: serves to increase the motor speed to more than 1500 rpm. Please note the maximum gearbox speed.

### Slower:

- Motors with more poles/lower speed (6-, 8-, 10- or 12-poles)
- Frequency converter (**CAUTION:** if the motor is to be operated for extended periods at frequencies less than 25 Hz, adequate cooling must be assured, e.g.: separately driven fan)
- Geared motor (**CAUTION:** do not exceed the maximum input torque)
- Bevel gearbox with gear reduction (only suitable for certain applications)

## Temperature and duty cycle

Screw jacks are generally not designed for continuous operation. Refer to the diagram on the gearbox pages (Sections 2 + 3) for the maximum duty cycles (ED). These are reference values but vary according to usage conditions. In borderline cases, select a larger screw jack or contact our project technicians. Operating temperatures must not exceed 60°C (gearbox) or 80°C (screw) (higher values on request).

## Rotation protection

On the version S, the translating screw is free running within the gearbox (worm wheel). The screw must be protected against rotation - otherwise it would rotate due to the friction in the worm wheel. This can be achieved by fixing the screw to an external guidance system or by using our rotation protection (VS) (in the protective tube).

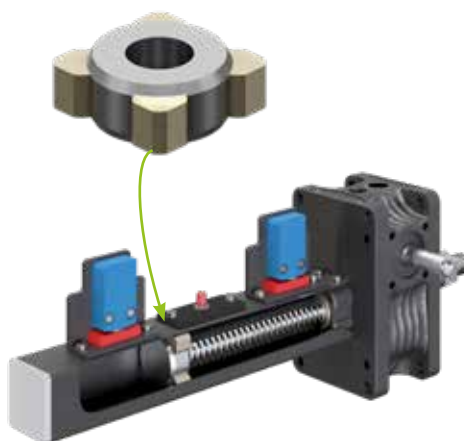

## Parallelism and angular relationships



Attention must be paid to the parallelism and correct angular relationships of mounting surfaces, gears, nuts and guides to each other. The same applies for exact alignment of gears, pedestal bearings, connecting shafts and motors to each other. We recommend aligning with the help of a precision machine spirit level.

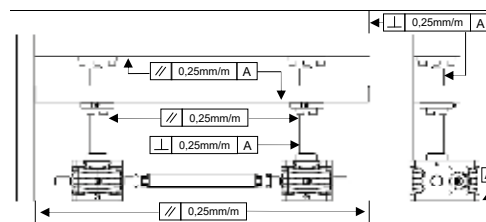

## Guides

Guide bush play in the screw jack gearbox can be between 0.2 mm and 0.6 mm depending on the size. This is just a secondary support and does not replace a guide system specifically provided to cater for lateral forces.







# Design advice

### Safety distance

Safety distances between moving and stationary components must be maintained otherwise there is the risk of the screw jack reaching a blocked position (see Gearbox Dimension Sheets).

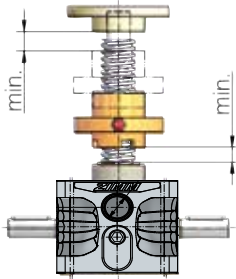

### Accuracy

The repetition accuracy of the gearbox can be up to 0.05 mm when moving to the same position again under the same load conditions.

This requires measures on the drive side, such as a 3-phase AC motor with a brake in conjunction with a frequency converter, a rotary pulse encoder or a servomotor with encoder, etc.

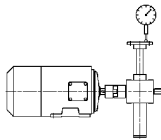

The **pitch accuracy** for trapezoidal screws is 0.2 mm over a 300 mm screw length, and 0.05 mm for ball screws over a 300 mm screw length.

Under alternating loads, axial play can be up to 0.4 mm on trapezoidal screws and 0.08 mm on ball screws (when new).

### Direction of rotation and movement

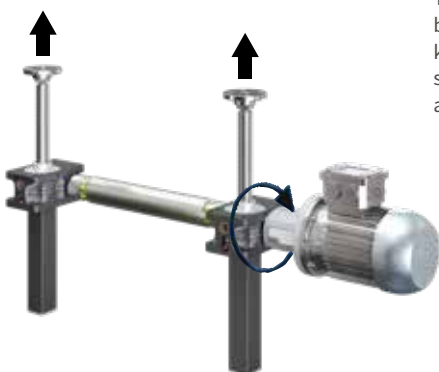

Check the direction of rotation required for the system and record this on the drawing or select one of our standard system layouts (Checklists). With T bevel gearboxes, the direction of rotation can be changed simply by turning the gearbox around.

### Self-locking / overrunning

Screw jacks with a single-pitch trapezoidal screw have a limited self-locking capability which cannot always be relied upon, especially where impact loads or vibrations are present (brake recommended).

The **overrun after** the motor has been switched off varies depending on the application. To minimize overrun, we recommend using a braked motor or a spring pressure brake FDB. A braked motor is essential for double-pitch screws or ball screws, because these are not self-locking.

### Drive

We recommend the use of a frequency converter to achieve smooth start-up and brake ramps.

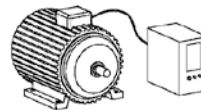

This minimizes start-up noise and extends the service life of the gearbox.

### Trial runs!

Trial runs without load and under load in normal operating conditions are necessary to ensure reliable operation. Do not exceed system duty cycle when loaded. These on-site trial runs are necessary to achieve system alignment and to eliminate any factors which may impair operation.

### Spare parts

To protect against loss of production caused by high duty cycles or high loads, we recommend keeping a set of screw jack spare parts (including screws, accessories and with assembly drawings) at your location or at your customer's location.

### Theatre stage design

We supply lifting equipment which satisfies the current regulations on theatre stage design.

### Land vehicles, aircraft and water craft

Our extended warranty terms generally do not apply to machine elements used in any land vehicles, aircraft and water craft. Special individual terms may be agreed on inquiry.

### Ambient conditions

Please specify any ambient conditions that are outside normal industrial environmental conditions (Checklists).



# Design advice

### Lubrication

Adequate lubrication is determine for the service life of a screw jack. Therefore ensure adequate lubrication of screws, gearboxes and rotation protection. The red lubrication strip for rotation protection can be mounted in alternative positions to meet your requirements (please specify).

Please also refer to our lubricator and our Instruction manual.\*

### Lubrication for short stroke applications S-Version:

For short stroke applications (stroke < gearbox height), take particular care to ensure lubrication of the trapezoidal screw. The simplest tactic is to specify the screw jack with a longer stroke than the gearbox height, and occasionally perform a lubrication stroke. Otherwise, contact our Engineering. Department for a suitable solution.\*

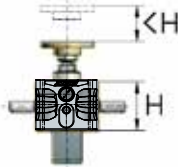

### R-Version:

If stroke length < nut height, use a nut with lubrication capability (such as a duplex nut DM).



### Instruction manual

Please refer to our Instruction manual during the design phase ([www.zimm.com](http://www.zimm.com)).

### Design advice for steel and plant construction:

Hardly any assembly problems arise when screw jacks are used in machine tools, because the relevant surfaces are machined faces.

In steel and plant construction however, frequent geometric errors can occur in welded structures, despite accurate fabrication work. The interaction between different components can also cause alignment issues. Attention must be paid to the following:

### Parallelism / angular relationships:

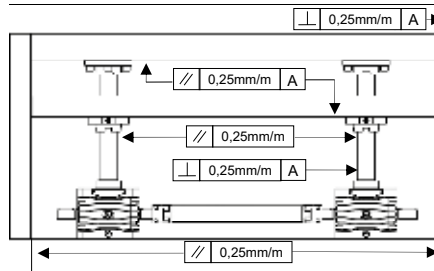

Screws and guides must be parallel to each other, otherwise the equipment can seize up during operation. All mounting surfaces for the gearboxes must be exactly at right angles to the guides, jamming may occur, leading to rapid wear and/or serious damage. Squeaking noises can also occur on R versions. We recommend aligning with the help of a precision machine spirit level. The mounting surfaces for the nuts must also be at right angles.

ZIMM has developed the self-aligning nut PM (see Section 3) to save time and costs here.

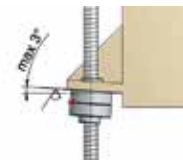
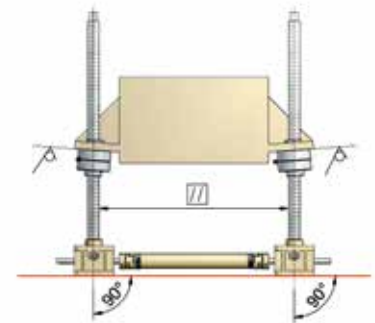

Additional features where alignment may be a problem are the integrated pivot bushings in the gearbox or the pivot bearing plate KAR (see Section 3).



# Procedure of specification

## a screw jack or lifting system



**NOTE:**  
When submitting enquiries and placing orders please always specify the parameters in accordance with the checklist (loads, speeds ...), so that we can check the application once again.



# Fixing

## Fixing – fixed

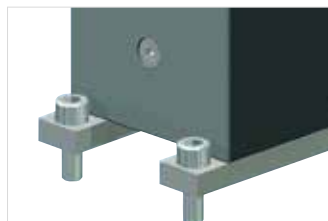

**Fixing strips (for the GSZ series):**  
Top mounting fixing strips BFL are required for attaching GSZ gearboxes from above.

### Through the mounting plate:

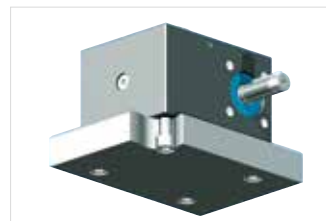

**Blind tapped holes (ZE- and GSZ-Series):**  
Z and GSZ series can be attached from underneath using the blind tapped holes in the gearbox. ZE size 5 to 25, GSZ-Series: all sizes

## Fixing - pivoting

### Duplex nut adapter DMA

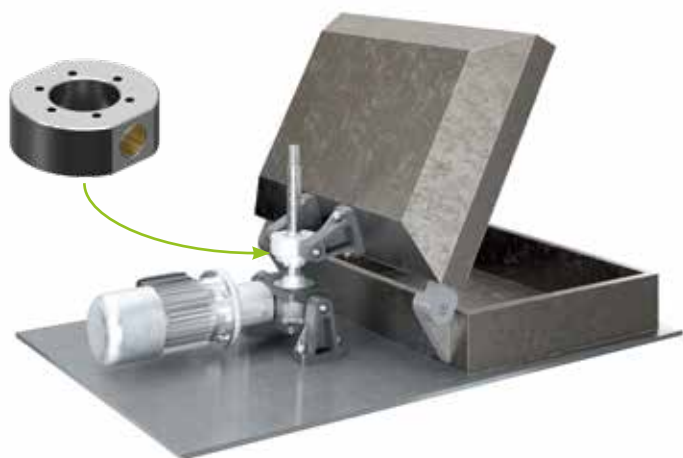

The duplex nut adapter DMA is simply bolted to the duplex nut DM. The pivot can be made with the pivot mounts LB or a mounting designed by the customer.

### Pivoting support tube STRO



The **pivoting support tube STRO** has the advantage that the pivot points are entirely external. The disadvantage is that the gearbox and motor weights are in the centre. The manufacture is always customer-specific.



# Fixing

## Fixing – pivoting

**ZE-5 to ZE-25**



**Integrated pivot bearing**

Simple and economical design: Pivot bushes are incorporated in the gearbox housing and PTFE-coated and therefore require no lubrication in normal service.

**Pivot bearing plate KAR**

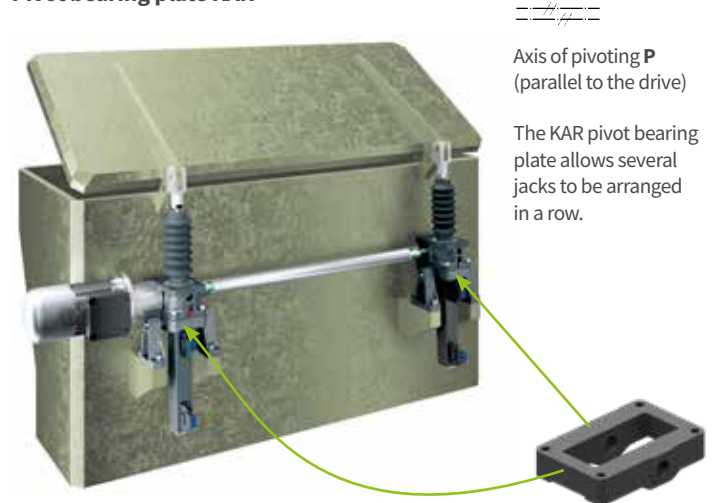

**With pivot bearing plate KAR**

For large motors, long strokes and high load cycles, the variant with the pivot bearing plate KAR is preferable, because the weight of the motor is then taken by the bearing points and does not affect the screw.

**Pivot mounts design for ZE-35 to ZE 200 and Z-250 to Z-1000**

**Integrated pivot bearing**

Simple and economical design: Pivot bushes are incorporated in the gearbox housing.



Pivot bearing plate KAR on request

**GSZ-2 to GSZ-150**

**with pivot bearing plate KAR**

For GSZ gearboxes, a pivot bearing plate can be mounted on face E (above) or F (underneath). In each case there are 4 holes available for the pivot plate P or R.

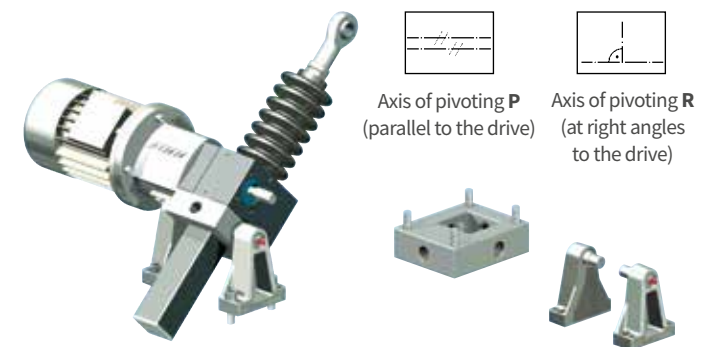



# Permissible loads

## Permissible loads – fixed

The screw jacks themselves are specified for full static nominal load under tension and compression. The permissible load depends on the type of fastening.

### Compressive load

#### Full rated load

The gearbox can accept the full static rated load.

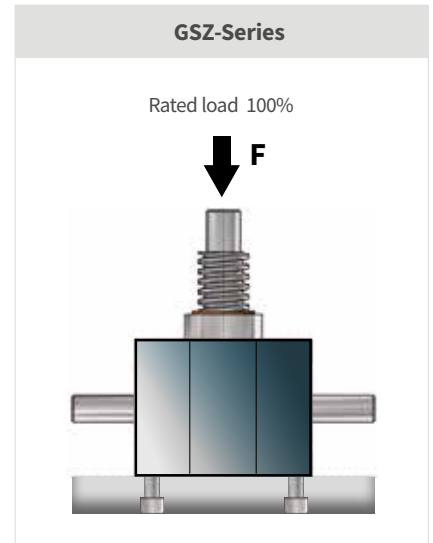
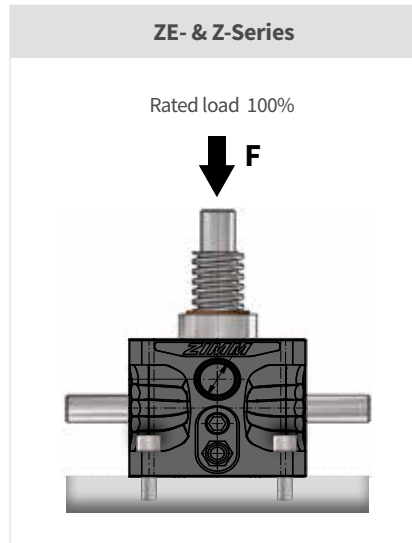

### Mounting plate with tensile load

#### Full rated load

The gearbox can accept the full static rated load.

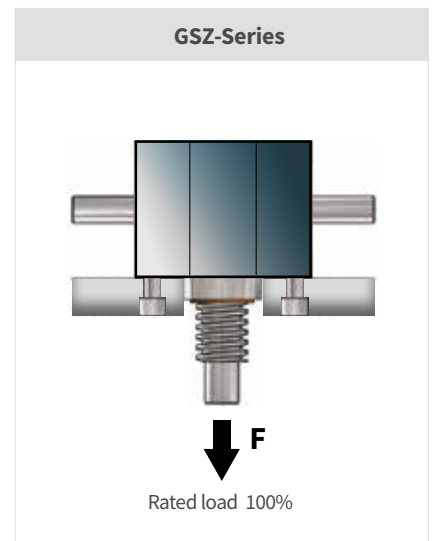
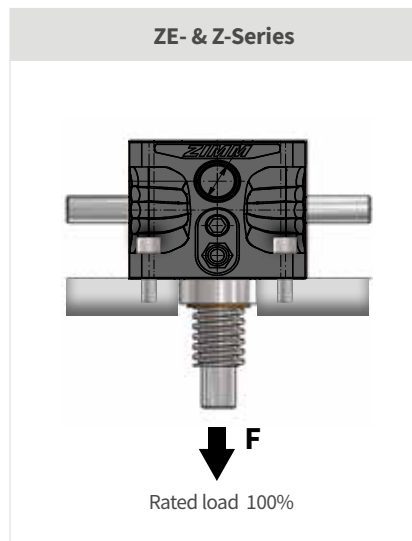



# Permissible loads

## Permissible loads – fixed

### Tensile load on the fixing screws (blind tapped holes)

#### Full rated load

Providing the screw-in depth is maintained and the screws are tightened to the full tightening torque, the full rated load is permissible.



Gearbox	Thread	Screw-in depth mm	Tightening torque Nm
GSZ-2	M6	8 bis 10	8
ZE-5	GSZ-5	M8	10 bis 11,5
ZE-10	GSZ-10	M8	10 bis 15
ZE-25	GSZ-25	M10	12 bis 15
	GSZ-50	M12	12 bis 17
	GSZ-100	M16	16 bis 20
	GSZ-150	M20	24 bis 27
			172

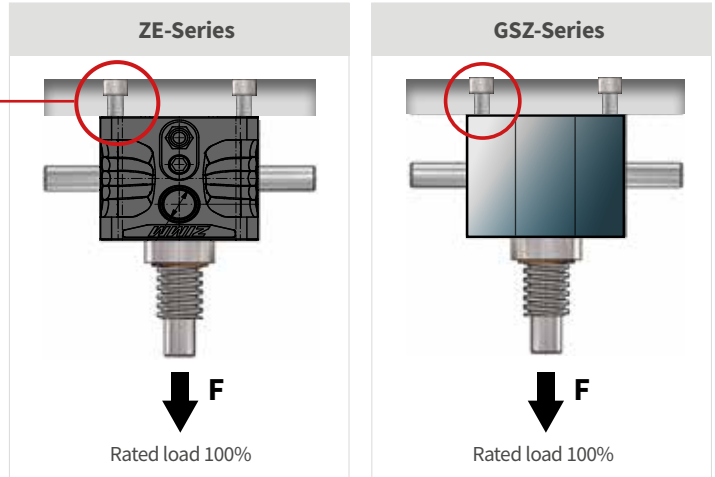

### Tensile load on the fixing screws (though holes in the housing)

Gearbox	Permissible load kN	with fixing screws*
ZE-5	100% Rated load	
ZE-10	100% Rated load	
ZE-25	100% Rated load	
ZE-35	100% Rated load	
ZE-50	100% Rated load	
ZE-100	100% Rated load	
ZE-150	100% Rated load	
ZE-200	100% Rated load	
Z-250	70	Rated load 250 kN
Z-350	180	Rated load 350 kN
Z-500	110	Rated load 500 kN
Z-750	210	Rated load 750 kN
Z-1000	on request	Rated load 1000 kN

\*Though holes and blind tapped holes, dimension sheet and screw-in depth on request.

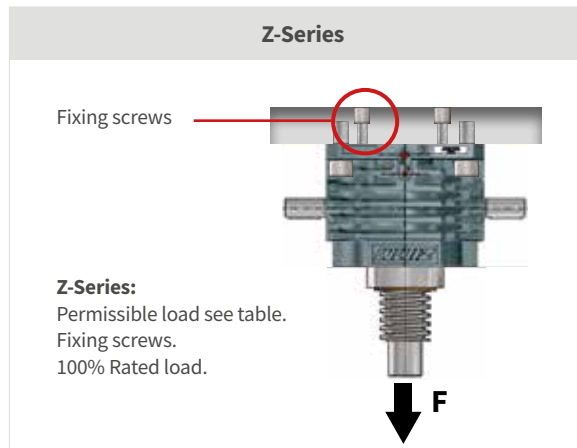
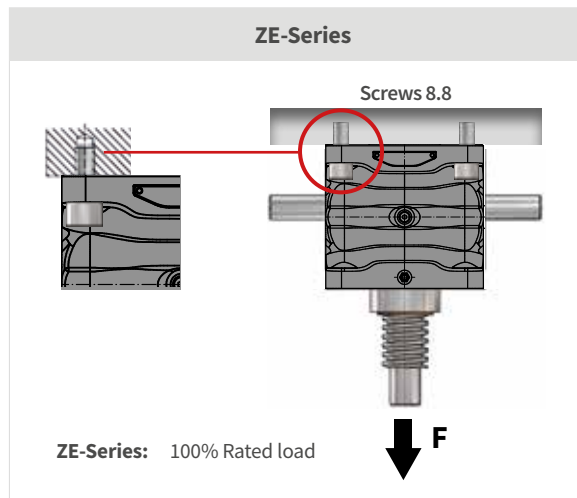



# Permissible loads

## Permissible loads – pivoting

### ZE & Z-Series pivot bearing in the housing

Pivot bushes are incorporated in the gearbox housing

#### ZE- and Z-Series:

Swivel bushes can be subjected to the full nominal load with either compression or tension.

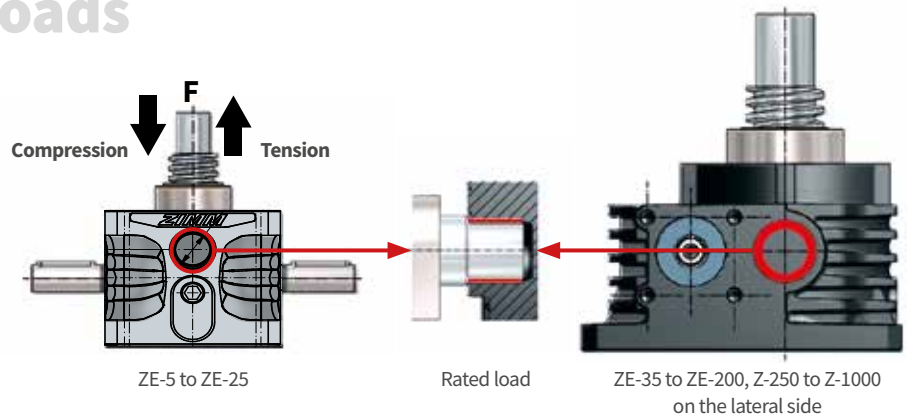

### Pivot mounts LB for ZE-5 to ZE-25

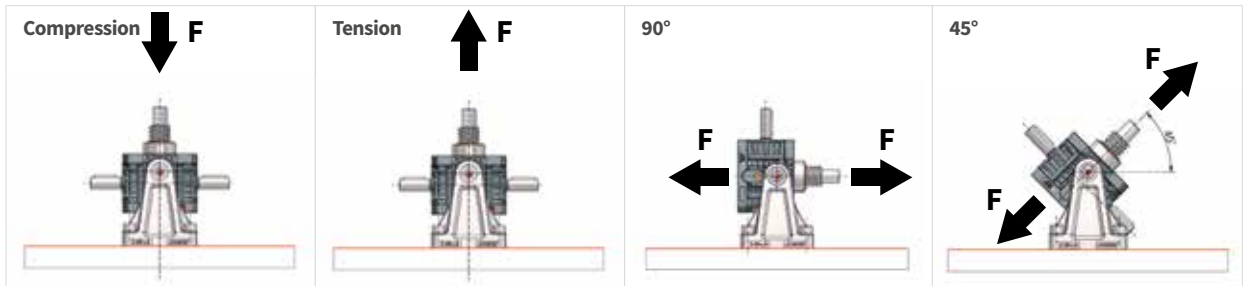

ZE-5 (ZE-5/10-LB)	Rated load 5 kN	Rated load 5 kN	Rated load 5 kN	Rated load 5 kN
ZE-10 (ZE-5/10-LB)	Rated load 10 kN	Rated load 10 kN	7 kN	6,5 kN
ZE-25 (ZE-25-LB)	19,5 kN	17,5 kN	10 kN	9,5 kN

### ZE-5 to ZE-25 – Pivot bearing plate KAR

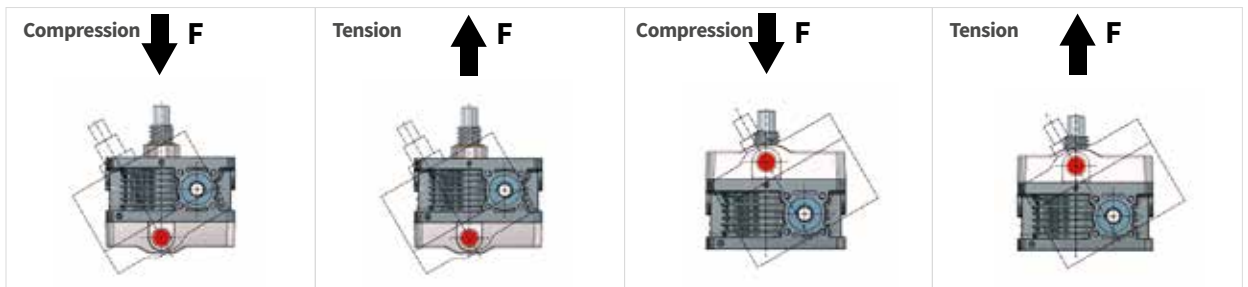

ZE-5-KAR	Rated load 5 kN	2,5 kN	2,5 kN	Rated load 5 kN
ZE-10-KAR	Rated load 10 kN	3,5 kN	3,5 kN	Rated load 10 kN
ZE-25-KAR	Rated load 25 kN	10 kN	10 kN	Rated load 25 kN

- When dimensioning, include all the parts you will use
- The direction of loading should be selected so that the gearbox is pressed against the pivot bearing plate. When the load is in the opposite direction, reduced load values apply.





# Permissible loads

## Permissible loads – pivoting

**ZE-35 to ZE-200 and Z-250 to Z-1000**  
 – Pivot bearing in the housing

For the design see table.

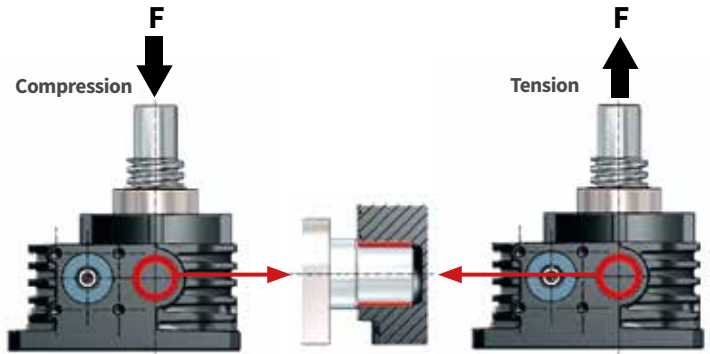
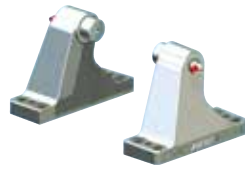

## Z-500 to Z-1000 Installation

From Z-500 the gearbox is mounted the opposite way round (Face F), since the footplate is broader than the rest of the housing.

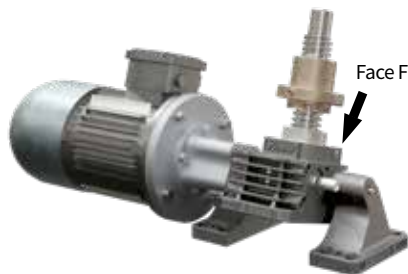

**Permissible loads gearbox housing**  
 Permissible load Pivot mount for tension, compression 90° and 45° direction of load

Gearbox	Compression	Tension	Permissible load Pivot mount for tension, compression 90° and 45° direction of load
ZE-35	Rated load 35 kN	Rated load 35 kN	Rated load 35 kN
ZE-50	Rated load 50 kN	Rated load 50 kN	Rated load 50 kN
ZE-100	Rated load 100 kN	Rated load 100 kN	Rated load 100 kN
ZE-150	Rated load 150 kN	Rated load 150 kN	Rated load 150 kN
ZE-200	Rated load 200 kN	Rated load 200 kN	Rated load 200 kN
Z-250	177 kN	Rated load 250 kN	Rated load 250 kN
Z-350	250 kN	260 kN	350 kN
Z-500	280 kN	310 kN	on request
Z-750	on request	on request	on request
Z-1000	on request	on request	on request

## ZE-35 to ZE-200, Z-250 to Z-1000 – Pivot mount LB

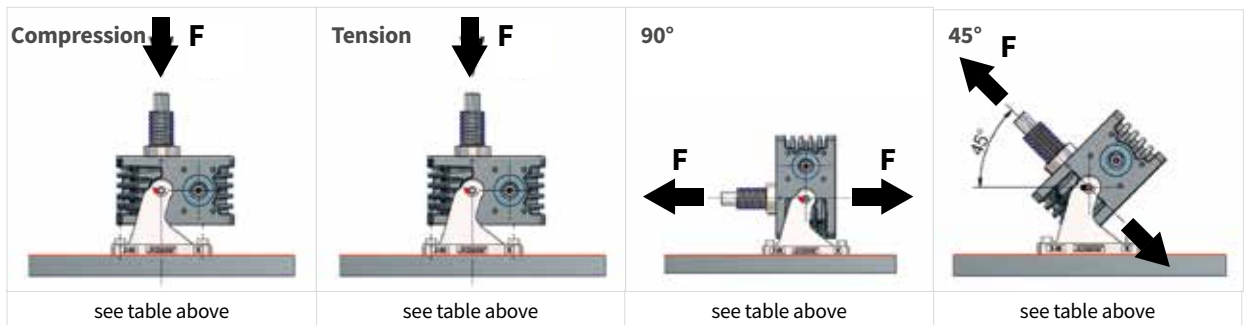

## Duplex nut adapter DMA



**Main direction of loading**  
 Select the main direction of loading so that tensile loads on the nut are avoided.

## Support tube STRO



In compression the full rated load permissible. In tension the support tube should be subjected only to limited loads.



# Critical buckling force of the screw

## Euler 1

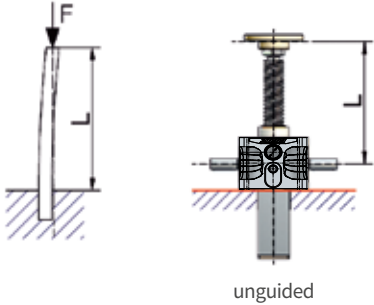

### Formula:

$$l = \frac{F \times v \times (L \times 2)^2}{\pi^2 \times E} \quad \text{then } d = \sqrt[4]{\frac{l \times 64}{\pi}}$$

### Example:

$$l = \frac{45.000 \text{ N} \times 3 \times (1.320 \text{ mm} \times 2)^2}{\pi^2 \times 210.000 \text{ N/mm}^2} = \frac{9,40896^{11} \text{ mm}^4}{2.072.616,924} = 453.965,22 \text{ mm}^4$$

$$d = \sqrt[4]{\frac{453.965,22 \text{ mm}^4 \times 64}{\pi}} = 55,15 \text{ mm minimum core diameter} = \text{Z-250 (screw core } \varnothing = 59,6 \text{ mm)}$$

## Euler 2

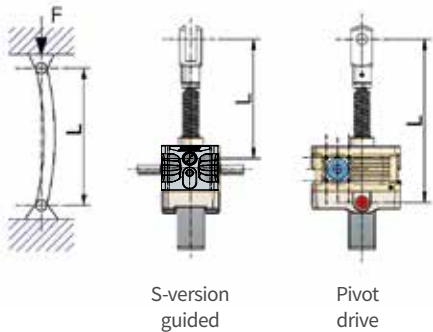

### Formula:

$$l = \frac{F \times v \times L^2}{\pi^2 \times E} \quad \text{then } d = \sqrt[4]{\frac{l \times 64}{\pi}}$$

### Example:

$$l = \frac{45.000 \text{ N} \times 3 \times (1.320 \text{ mm})^2}{\pi^2 \times 210.000 \text{ N/mm}^2} = \frac{2,35224^{11} \text{ mm}^4}{2.072.616,924} = 113.491,305 \text{ mm}^4$$

$$d = \sqrt[4]{\frac{113.491,305 \text{ mm}^4 \times 64}{\pi}} = 38,99 \text{ mm minimum core diameter} = \text{ZE-100 (screw core } \varnothing = 43,6 \text{ mm)}$$

## Euler 3

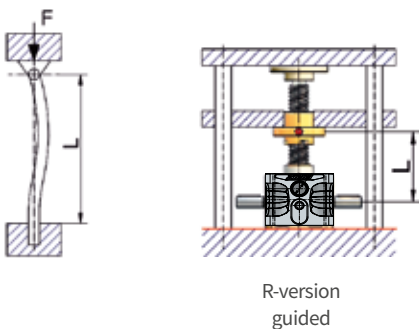

### Formula:

$$l = \frac{F \times v \times (L \times 0,7)^2}{\pi^2 \times E} \quad \text{then } d = \sqrt[4]{\frac{l \times 64}{\pi}}$$

### Example:

$$l = \frac{45.000 \text{ N} \times 3 \times (1.320 \text{ mm} \times 0,7)^2}{\pi^2 \times 210.000 \text{ N/mm}^2} = \frac{1,15259^{12} \text{ mm}^4}{2.072.616,924} = 55.610,7396 \text{ mm}^4$$

$$d = \sqrt[4]{\frac{55.610,739 \text{ mm}^4 \times 64}{\pi}} = 32,62 \text{ mm minimum core diameter} = \text{ZE-50/Tr50 (screw core } \varnothing = 39,8 \text{ mm)}$$

	GSZ-2	ZE-5	ZE-10	ZE-25	ZE-35/50	ZE-50/Tr50	ZE-100	ZE-150	ZE-200	Z-250	Z-350	Z-500	Z-750	Z-1000
Trapezoidal screw Tr Core-Ø in mm (minimum)	16x4	18x4	20x4	30x6	40x7	50x8	55x9	60x9	70x12	80x16	100x16	120x16	140x20	160x20
Core-Ø in mm (minimum*)	10,9	12,9	14,9	22,1	31	39,8	43,6	48,6	55,2	59,6	80,6	99,6	115	135
Ball screw KGT Ømm Core-Ø in mm (minimum*)	16	16	25	32	40	-	50	63	80	80	100	125	140	160
Core-Ø in mm (minimum*)	12,9	12,9	21,5	27,3	34,1	-	43,6	51,8	67	67	87,4	107,8	117	132,8

\*Depending on the pitch, the core Ø may be even larger. See the KGT pages in chapter 2 for the exact core Ø values.



### Explanatory notes:

- l = 2nd moment of area expressed in mm<sup>4</sup>
- F = Max. load/gearbox in N
- L = Free screw length in mm
- E = Modulus of elasticity for steel (210.000N/mm<sup>2</sup>)
- v = Safety factor (normally 3)
- d = Minimum core diameter of the screw

### Example:

- F = 45.000N/gearbox
- L = 1320 mm
- v = 3



# Critical whirling speed for R gearboxes

## Maximum permissible screw rotational speed

$$n_{zul} = 0,8 \times n_{kr} \times f_{kr}$$

$n_{zul}$  Maximum permissible screw speed (rpm)

$n_{kr}$  Theoretical critical screw speed (rpm) leading to resonant vibrations (see diagram)

$f_{kr}$  Correction factor which makes allowance for the type of screw bearing

**i** The operating rotational speed must not exceed 80% of the maximum rotational speed

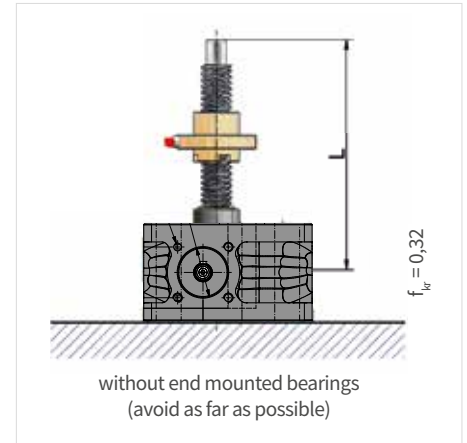
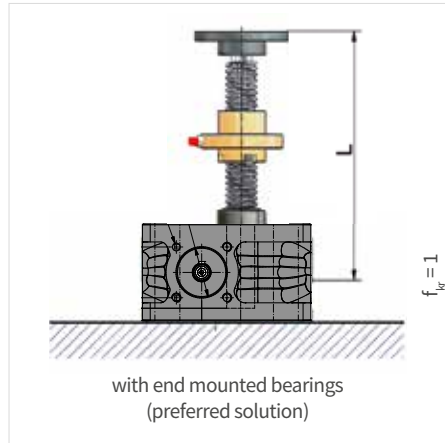

$$\text{Screw speed} = \frac{\text{Input drive speed}}{i_{\text{gearbox}}}$$

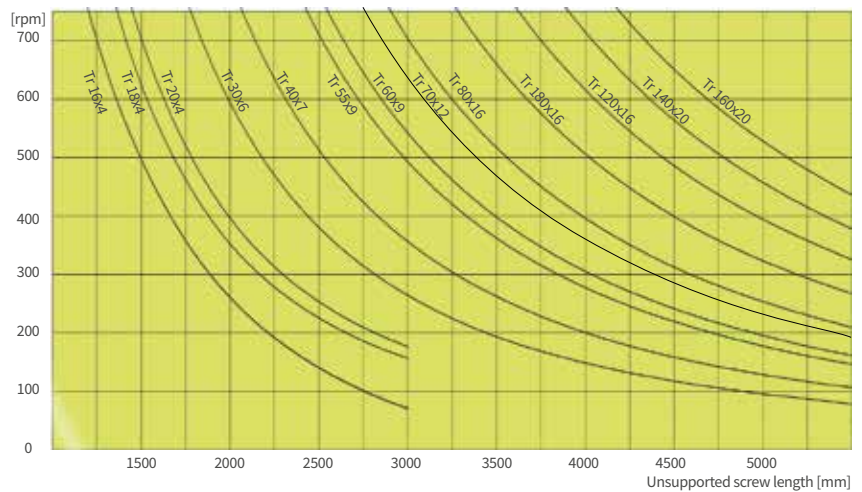

The maximum allowable screw speed must be calculated for R version gearboxes (with rotating screws) with long thin screws. To do this, read the theoretical critical speed  $n_{kr}$  from the diagram. Take into account also the additional lengths for screw covers etc. when calculating unsupported screw lengths. Now use the formula together with the correction factor for the screw bearing arrangement to calculate the maximum allowable screw speed.

If the calculated maximum screw speed is lower than the required speed, select a larger screw or a double-pitch screw with half the speed. This must then be checked also. You have the option to use a "increased screw" for the R version (screw for the next larger gearbox). Bear in mind that a larger pitch demands a higher drive torque.

**CAUTION:**

Long, thin screws can tend to squeak even though they satisfy the critical whirling speed! Therefore allow a sufficient margin of safety in the calculation.



# Drive torque [MG] of a single screw jack

The following specifications serve to calculate the required drive torque.

For gearboxes with single-pitch trapezoidal screws the load can simply be multiplied by the factor stated on the corresponding gearbox.

Formula:	Example:
1) Drive torque: $M_G = \frac{F \text{ [kN]} \times P \text{ [mm]}}{2 \times \pi \times \eta_{\text{Getriebe}} \times \eta_{\text{Spindel}} \times i}$	1) $M_G = \frac{12 \text{ kN} \times 6 \text{ mm}}{2 \times \pi \times 0,87 \times 0,39 \times 6} = 5,63$
2) Motor power: $P_M \text{ [kW]} = \frac{M_G \text{ [Nm]} \times n \text{ [min}^{-1}\text{]}}{9550}$	2) $P_M = \frac{5,63 \text{ Nm} \times 1500 \text{ min}^{-1}}{9550} = 0,88 \text{ kW}$
<b>3) Safety factor:</b> We recommend multiplying the calculated value by a safety factor of 1.3 to 1.5. For small sizes, low speeds and especially low temperatures, a safety factor of up to 2 is calculated.	3) Example: $0,88 \text{ kW} \times 1,5 = 1,32 \text{ kW} \rightarrow$ Motor 1,5 kW
<b>Minimum load:</b> With low dynamic loads, the no-load losses have a proportionally greater effect. Therefore calculate the drive with at least 15% of the gearbox rated load, even if the effective load is lower (e.g. Z-50 with at least 7.5 kN).	

- Explanatory notes:**
- $M_G$  Necessary drive torque [Nm] for a screw jack
  - $F$  Lifting load (dynamic) [kN]
  - $\eta_{\text{Gearbox}}$  Efficiency of the screw jack (without screw)
  - $\eta_{\text{Screw}}$  Efficiency of the screw
  - $P$  Screw pitch [mm]
  - $i$  Drive ratio of the screw jack
  - $P_M$  Motor drive power

**Example:**

**ZE-25-SN**  
 $F = 12 \text{ kN}$  (dynamic lift load)  
 $\eta_{\text{Gearbox}} = 0,87 \quad \eta_{\text{Screw}} = 0,39$   
 $i = 6 \quad P = 6$

### Efficiencies of the screw jack $\eta_{\text{Gearbox}}$ (without screw)

i	rpm	GSZ-2	ZE-5	ZE-10	ZE-25	ZE-35	ZE-50	ZE-100	ZE-150	ZE-200	Z-250	Z-350	Z-500	Z-750	Z-1000
N	3000	0,87	0,81	0,83	0,87	-	-	-	-	-	-	-	-	-	-
N	1500	0,87	0,82	0,84	0,87	0,87	0,87	0,88	0,89	0,90	0,91	-	-	-	-
N	1000	0,86	0,82	0,82	0,86	0,87	0,86	0,87	0,89	0,90	0,90	0,91	0,92	0,88	0,90
N	750	0,86	0,82	0,84	0,85	0,86	0,85	0,87	0,88	0,90	0,90	0,91	0,92	0,88	0,90
N	500	0,85	0,82	0,84	0,83	0,85	0,84	0,85	0,87	0,90	0,89	0,9	0,92	0,87	0,89
N	100	0,74	0,77	0,79	0,78	0,78	0,78	0,78	0,8	0,85	0,83	0,86	0,87	0,81	0,84
L	3000	0,78	0,74	0,78	0,76	-	-	-	-	-	-	-	-	-	-
L	1500	0,77	0,70	0,74	0,72	0,64	0,66	0,67	0,67	0,77	0,78	-	-	-	-
L	1000	0,75	0,67	0,72	0,7	0,64	0,66	0,65	0,66	0,77	0,77	0,78	0,76	0,67	0,76
L	750	0,74	0,65	0,7	0,68	0,64	0,66	0,65	0,65	0,77	0,76	0,78	0,75	0,66	0,76
L	500	0,71	0,62	0,67	0,65	0,63	0,65	0,65	0,63	0,76	0,75	0,77	0,73	0,65	0,75
L	100	0,54	0,53	0,59	0,54	0,52	0,55	0,57	0,53	0,67	0,65	0,67	0,61	0,58	0,66

### Efficiencies of the screws $\eta_{\text{Screw}}$ calculated for coefficient of friction $\mu = 0,11$

Tr-screw, single-pitch	16x4	18x4	20x4	30x6	40x7	50x8	55x9	60x9	70x12	80x16	100x16	120x16	140x20	160x20	Ball screw
Efficiency	0,45	0,42	0,39	0,39	0,35	0,33	0,34	0,32	0,35	0,39	0,33	0,29	0,30	0,27	
Tr-screw, double-pitch	16x8P4	18x8P4	20x8P4	30x12P6	40x14P7	50x16P8	55x18P9	60x18P9	70x24P12	80x32P16	100x32P16	120x32P16	140x40P20	160x40P20	0,9
Efficiency	0,62	0,59	0,56	0,56	0,53	0,50	0,51	0,48	0,52	0,56	0,50	0,45	0,47	0,44	



# Maximum torques

## Maximum input torque

In order to achieve optimum service life, do not exceed the values shown.  
If operating hours are lower, higher values may be achieved. Please contact us for advice.

### max. input drive torques MR [Nm]

i	rpm	GSZ-2	ZE-5	ZE-10	ZE-25	ZE-35	ZE-50	ZE-50/Tr50	ZE-100	ZE-150	ZE-200	Z-250	Z-350	Z-500	Z-750	Z-1000
N	3000	1,2	4	11	17	-	-	-	-	-	-	-	-	-	-	-
N	1500	1,4	4,7	13,5	18	19,8	31,5	31,5	53,4	75,1	155	152	-	-	-	-
N	1000	1,5	5,6	14	22	20,8	36,8	36,8	60,8	77,7	155	152	265	408	480	680
N	500	1,6	6,1	16,7	28	24,8	46,5	46,5	75,3	95	156	160	350	500	640	960
L	3000	0,5	1,4	5,7	8,5	-	-	-	-	-	-	-	-	-	-	-
L	1500	0,5	1,5	7,5	10	9	10,4	10,4	13,5	20,7	61	41,4	-	-	-	-
L	1000	0,5	1,8	8,7	11	9,7	14,9	14,9	15,4	23,7	61	47,4	100	170	210	450
L	500	0,6	2,2	10,7	14	11,1	19,2	19,2	18,9	29,4	62	63,5	112	220	240	580

The stated limit values are mechanically-based - thermal factors may be relevant depending on the duty cycle

## max. drive-through torque

Where several gearboxes are arranged in series the drive-through torque may be significantly greater than the maximum input drive torque. Only the torsional load on the shaft needs to be considered, not the load on the gear teeth.

### max. worm shaft drive-through torqu [Nm]

GSZ-2	ZE-5	ZE-10	ZE-25	ZE-35	ZE-50	ZE-50/Tr50	ZE-100	ZE-150	ZE-200	Z-250	Z-350	Z-500	Z-750	Z-1000
9	39	57	108	130	260	260	540	540	700	770	1800	1940	4570	4570



# Drive torque for screw jacks

## - approximate calculation

### Calculation

The drive torque required for a lifting system is the sum of the torques for the individual screw jacks and increases due to frictional losses on transfer components such as couplings, connecting shafts, bevel gearboxes etc.

To simplify the calculation, the following factors are used to determine the drive torque for the most common system layouts.

- i**  $M_R$  - Overall drive torque for the entire system
- $M_G$  - Drive torque for an single gearbox
- $M_A$  - Starting torque max.  $1,5 \times M_R$

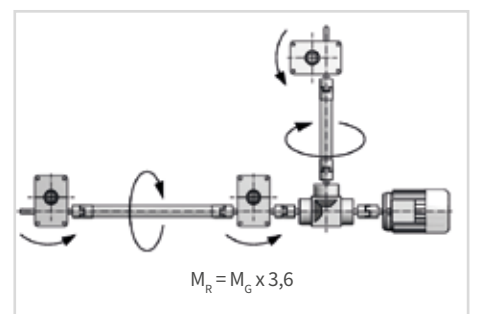
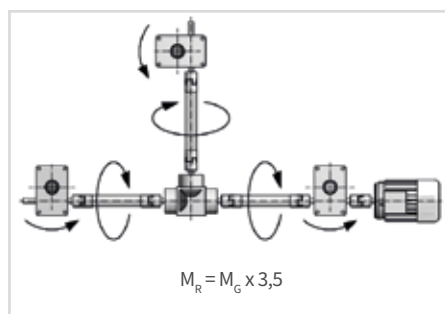
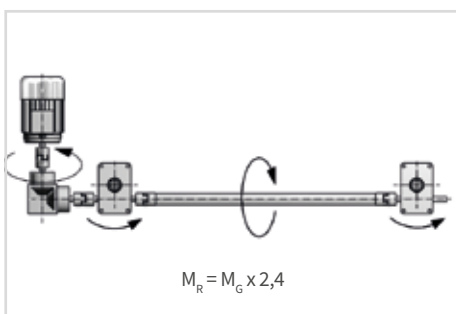
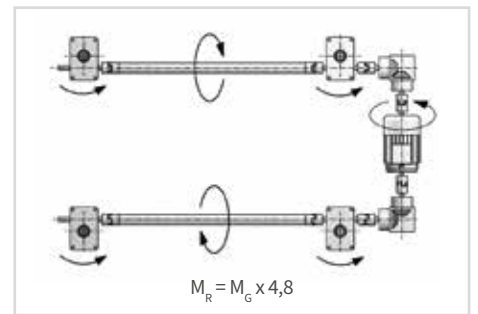
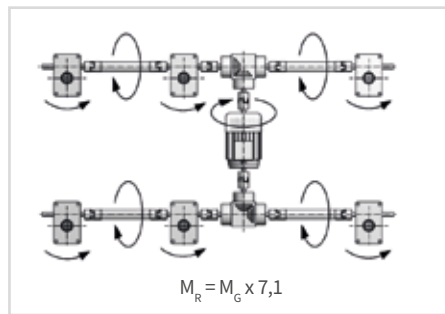
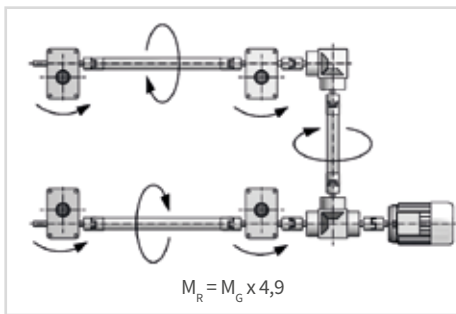
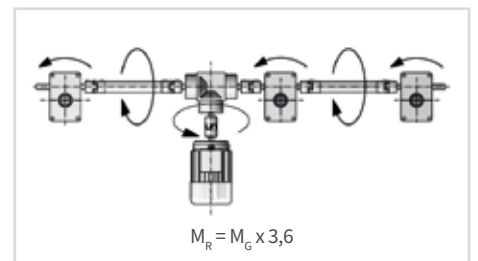
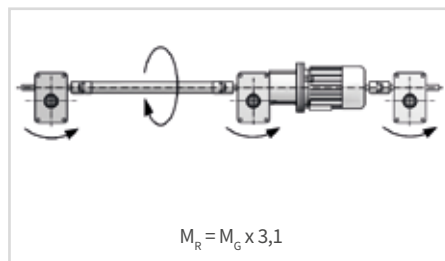
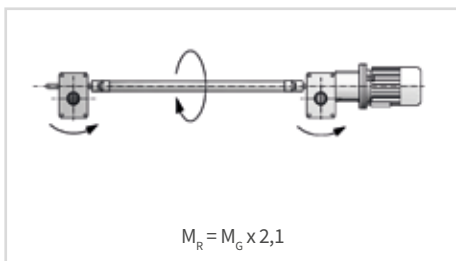

### CAUTION

We recommend multiplying the calculated value by a safety factor of 1.3 to 1.5. For small sizes, low speeds and especially low temperatures, a safety factor of up to 2 is calculated.

### Example (12 kN per gearbox)

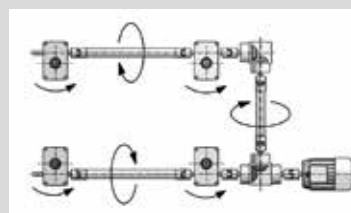

$$M_R = M_G \times 4,9 = 5,63 \text{ Nm} \times 4,9 = 27,59 \text{ Nm}$$

$$\rightarrow \times \text{ safety factor } 1,5 = 41,38 \text{ Nm}$$

$$M_A = M_R \times 1,5 = 41,38 \text{ Nm} \times 1,5 = 62,07 \text{ Nm}$$



# Drive torque for screw jacks

## - precise calculation

The following calculation example takes account of the efficiency of the connecting shafts ( $\eta$  0.95) and bevel gearboxes ( $\eta$  0.9).

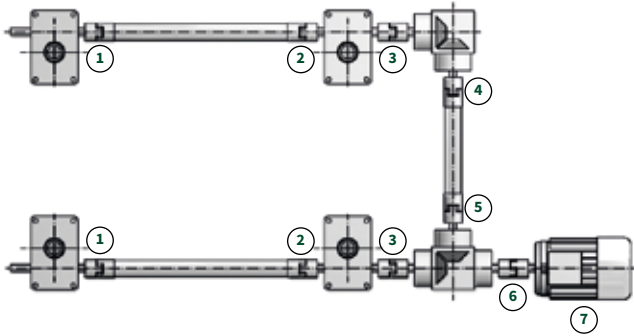

**Formula for the gearbox:**

$$\text{Drive torque: } M_G = \frac{F \text{ [kN]} \times P \text{ [mm]}}{2 \times \pi \times \eta_{\text{Getriebe}} \times \eta_{\text{Spindel}} \times i}$$

**Efficiencies:**

Connecting shafts:  $\eta$  0,95  
 Bevel gearbox:  $\eta$  0,90

**Example:**

$$1) \quad M_G = \frac{12 \text{ kN} \times 6 \text{ mm}}{2 \times \pi \times 0,87 \times 0,39 \times 6} = \mathbf{5,63}$$

$$2) \quad \frac{5,63 \text{ Nm}}{0,95} = \mathbf{5,93 \text{ Nm}}$$

(efficiency of the connecting shaft)

$$3) \quad 5,63 \text{ Nm} + 5,93 \text{ Nm} = \mathbf{11,56 \text{ Nm}}$$

$$4) \quad \frac{11,56 \text{ Nm}}{0,9} = \mathbf{12,84 \text{ Nm}}$$

(efficiency of the bevel gearbox)

$$5) \quad \frac{12,84 \text{ Nm}}{0,95} = \mathbf{13,52 \text{ Nm}}$$

$$6) \quad (11,56 \text{ Nm} + 13,52 \text{ Nm}) / 0,9 = \mathbf{27,87 \text{ Nm}}$$

$$7) \quad 27,87 \text{ Nm} \times 1,5 = \mathbf{41,8 \text{ Nm}}$$

**Z-25-SN**

F = 12 kN (dynamic lift load per gearbox)  
 $\eta_{\text{Gearbox}} = 0,87$        $\eta_{\text{Screw}} = 0,39$   
 i = 6      P = 6

11,56 Nm x 1,5 = 17,34 Nm  
 (KSZ-H-25-L is okay - see chapter 5)

41,8 Nm  
 (KSZ-H-35-T is needed - see chapter 5)

**Motor selection: 132M-P4-7,5 kW (50 Nm)**  
 (for motors see Section 3)

**CAUTION**

We recommend multiplying the calculated value by a safety factor of 1.3 to 1.5. For small sizes, low speeds and especially low temperatures, a safety factor of up to 2 is calculated.



# maximum forces / torques

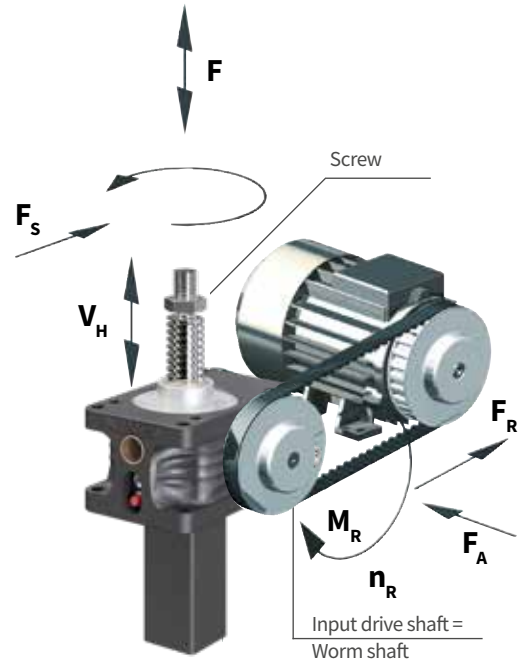

### Lateral forces on the lifting screw

The maximum permissible lateral forces are shown in the table on the right. Lateral forces should generally be taken by linear guides. The guide bushing in the gearbox functions only as a secondary guide. The maximum lateral forces actually occurring must be less than the values shown in the table!

**CAUTION: Only applies to static forces!**

maximum lateral force  $F_s$  [N] (only static)

extended screw length in mm

ZE/Z	100	200	300	400	500	600	700	800	900	1000	1200	1500	2000	2500	3000
5	360	160	100	70	55	45	38	32	28	25	20	18	12	-	-
10	600	280	180	130	100	80	70	60	50	47	40	30	20	15	-
25	900	470	300	240	180	150	130	110	100	90	70	60	45	35	30
35	1300	700	450	360	270	220	190	160	150	130	100	90	60	50	40
50	3000	2000	1300	900	700	600	500	420	380	330	280	230	160	130	100
100	5000	4000	3000	2300	1800	1500	1300	1100	950	850	700	600	400	350	250
150	5500	5000	3900	2800	2300	1800	1500	1300	1200	1000	850	750	500	400	350
200	7500	7200	5400	4000	3200	2500	2100	1800	1700	1500	1200	1050	700	600	500
250	9000	9000	6500	4900	3800	3000	2500	2200	2000	1900	1450	1250	900	760	660
350	15000	13000	12000	10000	8800	7000	6000	5500	4800	4300	3500	3000	2000	1600	1400
500	29000	29000	29000	29000	24000	20000	17000	15000	15000	14000	12000	9000	7000	5600	4900
750	34800	34800	34800	34800	34800	28800	24000	20400	18000	16800	14400	10800	8400	6720	5880
1000	46000	46000	39000	36000	320000	30000	25000	290000	25000	23500	20000	17000	12000	10000	8000

### Radial load on the input shaft

Make sure that the radial forces arising where chain or belt drives are used do not exceed the values stated in the table alongside.

maximum radial load on the input shaft  $F_R$  [N]

	ZE-5	ZE-10	ZE-25	ZE-35	ZE-50	ZE-100	ZE-150	ZE-200	Z-250	Z-350	Z-500	Z-750	Z-1000
FR max.	110	190	260	260	420	650	670	1000	1100	1400	2600	3000	3400

- i** Loading definitions:
- F - Lifting load tensile and/or compressive
  - $F_s$  - Lateral loads on the screw
  - $v_H$  - Lifting speed of the screw (or nut if the R version)
  - $F_A$  - Axial load on the input shaft
  - $F_R$  - Radial load on the input shaft
  - $M_R$  - Input torque
  - $n_R$  - Input speed





# Length calculation – screw and protective tube

## A quicker method

Take advantage of the ZIMM online configurator to easily and conveniently determine the required spindle and protection tube extension. This lets you quickly calculate the fitting dimensions of your screw jack.

## Principle

Depending on the version and accessories used the screw (and the protective tube on the S version) are extended. These dimensions are minimum requirements. For special fitting situations, please provide a drawing or contact our project technicians.

Stroke + basic length (+ various extensions for variants/accessories)

## Example S:

### ZE-25-SN, stroke 250 mm:

- Bellows ZE-25-FB-300 (ZD=70mm)
- Fixing flange BF (means the bellows do not require an fixing ring)
- Rotation protection VS
- Limit switch ESSET

#### Screw length Tr:

250 Stroke	+	180 Basic length	+	44 Bellows (70 - 26 = 44)	+	45 Limit switch + Rotation protection	=	<b>519 mm</b> <b>Screw length</b>
---------------	---	---------------------	---	---------------------------------	---	---	---	--------------------------------------

#### Screw length SRO:

250 Stroke	+	53 Basic length	+	72 Limit switch + Rotation protection	=	<b>375 mm</b> <b>Protective tube length</b>
---------------	---	--------------------	---	---	---	--

## Example R:

### ZE-25-RN, stroke 250 mm:

- Screw with end support (opposed bearing plate GLP)
- Bellows ZE-25-FB-300 (ZD=70mm) underneath and above
- Duplex nut DM

#### Screw length Tr:

250 Stroke	+	189 Basic length	+	60 Bellows gearbox side (70 - 10 = 60)	+	55 2nd bellows (70 - 15 = 55)	+	50 Duplex nut	=	<b>554 mm</b> <b>Screw length</b>
---------------	---	------------------------	---	---	---	-------------------------------------	---	------------------	---	--------------------------------------

See Section 4 for the length calculation for connecting shafts.

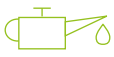

## Operational reliability and safety

### Operational reliability and safety

Operational reliability and safety are just as important for industrial systems as for theatre stages and other systems.

### Design and specification

During the design and specification phase, pay special attention to the load capacity of the drives and accessories in their proposed installation situation. Plan your system with appropriate safety for attachment, movement and transport elements.

Please note the design advice given in this chapter.

Where the system is safety-relevant, fit a safety nut SIFA. If the nut thread is stripped due to wear, the SIFA takes the load. An electronic control is available on request.



### Installation

Correct and careful installation is essential for trouble-free and safe system operation. Please refer to our instruction manual included with each delivery. You can download these from the Internet at [www.zimm.com](http://www.zimm.com).



### Inspection and maintenance

Regular inspection and maintenance are necessary to maintain reliability. Check the following during the regular inspections: Visual condition, attachments and connections, wear on the trapezoidal thread and the level of lubrication. Comply with our lubrication instructions and use only the lubricants we recommend. Please consider our automatic lubricator Z-LUB.



### Spare parts

To protect against loss of production caused by high duty cycles or high loads, we recommend keeping a set of screw jack spare parts (including screws, accessories and with assembly drawings) at your location or at your customer's location. A screw jack can most economically be repaired by a complete exchange.

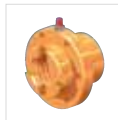

Screw jack with safety nut SIFA

 ZIMM Betriebsanleitung in anderen Sprachen und für spezielle Produkte erhalten Sie auf Anfrage oder im Internet zum Download unter [www.zimm.com](http://www.zimm.com)

# Ordering code

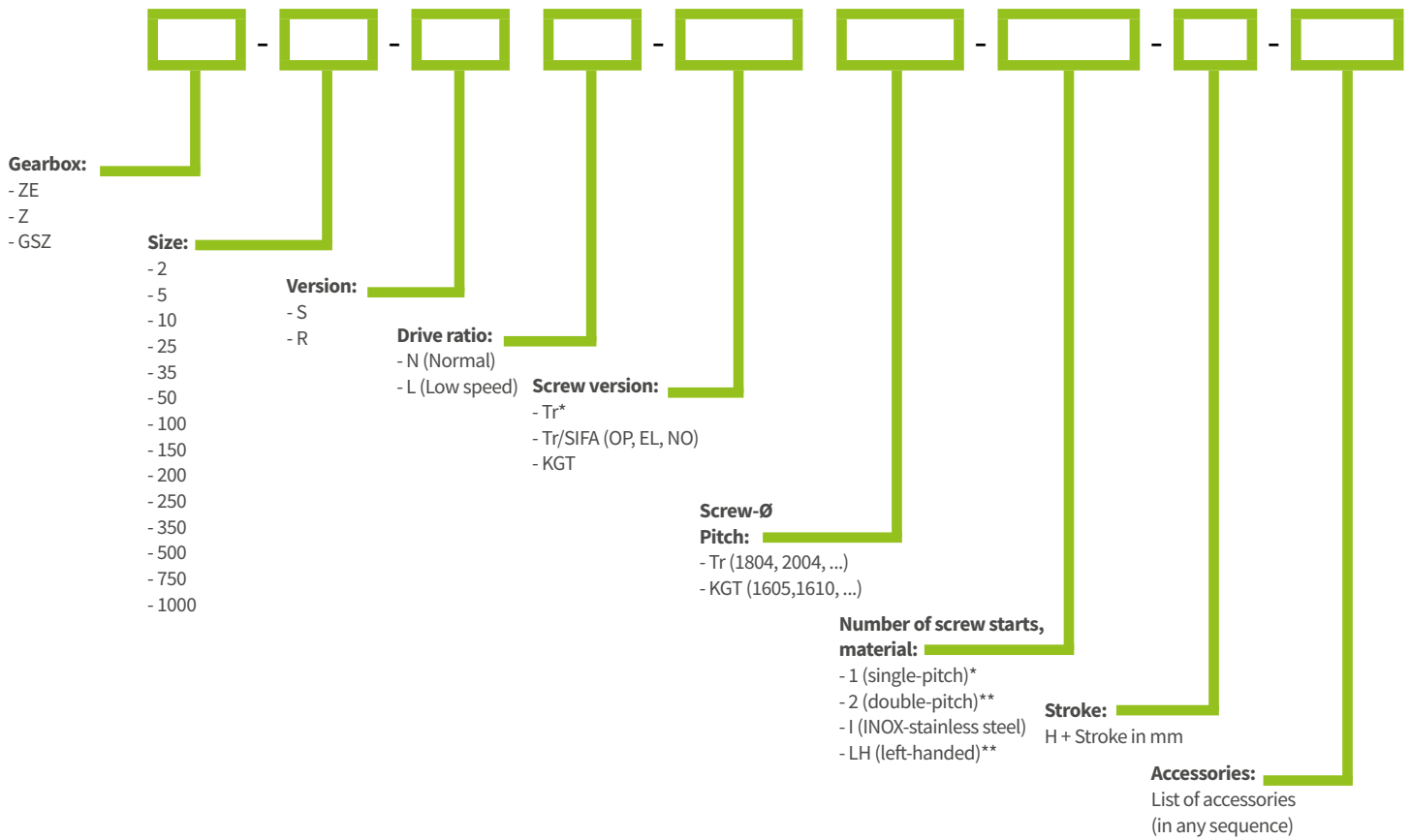

\*not stated = standard  
 \*\*is available but not ex stock. Lead time on request.



**For enquiries or orders you may optionally:**  
 - either list the parts individually  
 - or define the complete screw jack in an ordering code in the format specified here

**Ordering example: ZE-10-SN-Tr2004-1-H 300-FB390-VS-BF**

Gearbox, type	_____↑
Size	_____↑
Version S or R	_____↑
Drive ratio N or L	_____↑
Screw version	_____↑
Screw diameter, screw pitch	_____↑
Number of starts	_____↑
Stroke	_____↑
List of accessories (in any sequence)	_____↑



# Temperature

The ambient temperature is very important for system operation. Always inform us about ambient temperature and conditions, especially if these deviate from the usual 20°C to 25°C.

### Normal temperature

Always specify on your enquiry and order if the equipment will be exposed to ambient temperatures below 10°C or above 40°C. The highest temperature rises in operation occur at the shaft seal ring and on the trapezoidal screw. The Tr spindle can achieve a rise in temperature double that at the gearbox.



### Low temperature

The seals and most of our lubricants we use are specified in principle for operating temperatures down to -30°C. However the design should be checked for suitability if operating temperatures below 10°C are envisaged. Lubricants become stiffer and the break-away torque becomes higher.



### High temperature

For operating temperatures above 60 °C we recommend the use of high-temperature grease in the gearbox, and the use of FPM seals. (standard paint finish up to 90 °C).

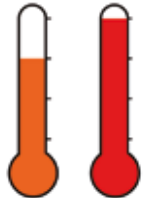

### Example:

In operation at an ambient temperature of 20°C, the gearbox reaches 60°C (rise of 40°C) and the Tr screw about 100°C (rise of 80°C).

Generally speaking, all components must be sized adequately for temperatures below zero, because the material strength is reduced.

For operating temperatures please contact us so that we can offer appropriate solutions.

The temperature of the Tr spindle should not be allowed to exceed 100°C.

### Temperature range of standard parts:

Standard screw jacks	- 20°C to + 80°C (when <10°C or >40°C please contact us)
High temperature screw jacks	up to 100°C or 150°C
Round bellows	- 20°C to + 70°C (max. + 85°C)
Polygonal bellows	- 15°C to + 70°C (no exposure to direct sunlight)
Limit switch	- 40°C to + 70°C
Limit switch cable standard	-25°C to + 70°C
Limit switch cable special	- 40°C to + 105°C
Motors	ab 40°C reduced power, e.g. factor 0.8 at 60°C
Connecting shafts VWZ+KUZ-KK	0°C to 70°C, reduced from - 20°C to + 100°C (max. + 120°C)
Couplings KUZ	- 20°C to + 70°C reduced from - 30°C to + 100°C
Bevel gearboxes	- 10°C to + 90°C
Ball screws KGT	- 20°C to + 80°C

For lower and higher temperatures, please request information on the component from us, with your checklist.

### Ambient and operating temperatures:

The ambient temperature is relevant for components such as limit switches or bellows. For gearboxes, the operating temperature is slightly or considerably higher than the ambient temperature, depending on the duty cycle.

# Clean room, food industry, resistant against corrosion

## Sectors

Various fields such as semiconductor production, flat screen production, optical and laser technology, spacecraft production etc. demand high cleanliness, which means that clean room standards must be maintained.



## Clean room

A clean room is a room where the concentration of particles in the air is controlled and satisfies defined cleanliness classes. It is important to keep the particle contamination caused by work materials, lubricants and drives to a minimum.

## Your system

Use the checklist to enquire about the system you require and also specify the particular requirements for your application. We can then offer you a system to meet your requirements.

## Food industry



## Food industry sector

The foodstuffs sector operates at a very high level of automation. On the one hand this promotes a very high level of hygiene, on the other hand it permits intelligent and efficient systems for economic production.

## Resistant against corrosion

Our ZE, Z and GSZ series are corrosion-resistant and are therefore very suitable for most applications in the food industry. The GSZ gearbox with its smooth surfaces is particularly suitable.

## Lubricants

We supply gearboxes and systems with food grade grease to the food industry. Our food grade greases are FDA-approved. Use the checklist to enquire about the system you require and also specify the particular requirements for your application.

## Resistant against corrosion

### Standard corrosion protection

When installed indoors in heated buildings with neutral ambient conditions.  
Max. surface temperatures up to 90°C.

All relevant components of the ZIMM ZE series, Z series and GSZ series for these operating ranges are coated as standard against corrosion. The colours black, anthracite and silver are visually neutral and fit in with any colour combination.

### Standard

### Enhanced corrosion protection

If installed outdoors or if subject to condensation or direct exposure to the weather.

Enhanced corrosion protection by additional coatings or special paint finishes, possibly stainless steel spindles, UV-resistant or moisture-resistant gaiters.

### Premium

### Special corrosion protection

For environments containing chemical pollutants, in coastal areas and exposed to other aggressive conditions.

Special corrosion protection by the use of stainless steel components or other special measures.

### Extra protection

# © ZIMM 2021

Owner, publisher and responsible for the content:

## ZIMM GmbH

Millennium Park 3, 6890 Lustenau/Austria

Tel: +435577 806-0, Fax: +435577 806-8

info@zimm.com, www.zimm.com

ATU 69063247, Feldkirch

ARA-Lizenznummer 4334

## Bank accounts:

### Austria (A):

Raiffeisenlandesbank Bregenz

IBAN AT40 3700 0000 0001 1999, BIC RVWGAT2B

### Switzerland (CH):

BTV Staad

IBAN CH11 0852 5000 SA31 733A B,

BIC BTVACH22



## Protection mark

### for restricting the use of documents to DIN ISO 16016.

Except where indicated otherwise, reprinting, plagiarism, reprinting of extracts, copying of graphics and text are subject to the copyright © of ZIMM GmbH, Millennium Park 3, 6890 Lustenau/Austria.

Storage, duplication, reproduction and distribution of the contents, in whole or in part, is permitted only with the written approval of ZIMM GmbH, 6890 Lustenau.

Breach of copyright creates liability to claims for damages.

All rights are reserved in respect of granting of patents or industrial licences.

## ISO quality management certificate

Certified according to the requirements of ISO 9001:2015

First certified: 17.12.1996 | Registration number: 00953/0

## Patents

We have patents registered or pending for a range of functions and components.

## Copyright and rights of use

All copyright and rights of use regarding information, artwork, photographs and drawings presented on our website and in our catalogues are reserved exclusively to us. Text and graphics are protected by copyright. Their use, duplication and re-use – especially where this involves distribution to third parties – requires our express permission in writing.

## Exclusion of liability

Neither our website nor our catalogues ranks as commercial or legal advice.

Such a commitment requires a specific enquiry and conclusion of a contract with us.

The contents of our catalogues and website are not binding and do not constitute an offer to conclude a contract. We accept no liability for the currency, accuracy or completeness of their contents. This applies in particular to contents of external websites accessed by links from our website. We are entitled to change the contents of our catalogues and website at any time. We accept no liability for and make no guarantee of the availability of our website or catalogues.

**Drawings are valid only when they have been checked and approved by both partners in accordance with the order acknowledgement.**

## Effectiveness at law of the exclusion of liability

If a legal relationship has arisen exclusively from the contents of our website or catalogues without any direct contact between us, this is subject exclusively to Austrian law, with exclusion of the tie-breaker rule. All legal disputes arising shall be subject to the exclusive jurisdiction of the court having competence A-6800 Feldkirch.

## Data protection declaration

We are subject to the provisions of the Austrian Federal Data Protection Act for protection of personal data. We will pass personal information and data relating to persons to other parties only where this is for the purpose of and in relation to contractual orders. Information may be passed to suppliers and subcontractors only where such companies which can offer sufficient guarantees of secure use of the data. We are permitted to pass data to companies directly or indirectly associated with us.

# GENERAL TERMS AND CONDITIONS

## 1. Company

ZIMM GmbH | Millenniumpark 3 | A-6890 Lustenau | Phone: +43 (5577) 806-0 | E-Mail: info@zimm.com | www.zimm.com | VAT Number: ATU69063247

## 2. Offer, conclusion of the contract:

2.1 The following terms and conditions apply to all present and future deliveries and services of ZIMM GmbH, even if no explicit reference is made to them. Deviating terms and conditions or delivery terms of the customer are only valid with our written consent. Persons who place orders or deliver or collect goods for processing shall be deemed to be authorized to accept our terms and conditions on behalf of the customer and to make reservations in this respect.

2.2 Our offers shall remain valid for 60 days after submission, unless otherwise agreed.

We are entitled to adjust our offers and orders accordingly in the following cases:

economic changes, new circumstances concerning raw materials, taxes, wage rates, currency differences, strikes, war, terrorist attacks, blockades, fire, natural disasters, other cases of force majeure or general circumstances outside our sphere (in particular in the event of a change of more than 10% in the price of aluminum or copper). In these cases we are also entitled to adjust our prices/dates after conclusion of the contract.

2.3 The information in our catalogue is not binding.

2.4 The conclusion of a contract shall only be legally effective if we confirm an order in writing. Partial deliveries are permissible.

2.5 Our employees are not entitled to make agreements that deviate from our general terms of conditions, delivery terms or list prices. Such agreements require our written confirmation.

2.6 The contents of our order confirmations are to be checked by the recipient and the recipient is obliged to give immediate notice of any deviations from the order transmitted by him. If the recipient fails to do so, the transaction is concluded in accordance with the contents of our order confirmation.

## 3. Prizes, Costs and Payments:

All prices are non-binding and are quoted - unless otherwise stated - in Euro and exclusive of VAT. Unless otherwise agreed, the prices according to our current price list valid at the time of conclusion of the contract shall be charged. The prices are ex works, without packaging and loading. All transport and packaging costs, freight and insurance charges, customs duties, fees and charges are to be borne by the customer. The statutory value-added tax will be invoiced additionally at the rate applicable at the time.

3.2 Unless otherwise agreed, our invoices shall be paid immediately upon receipt free of charges and deductions. Bank transfers shall only be considered as payment upon receipt on our account.

3.3 If the customer is in default of payment, we are entitled to demand compensation for the actual damage incurred as well as default interest at the statutory rate, but at least at the usual bank interest rate for current account credits (Kontokorrentkredit) plus VAT. In the event of default of payment, the customer also undertakes to reimburse us for the dunning and collection expenses incurred by us. In the event of a default in (partial) payment, we shall be entitled to declare open but not yet due invoice amounts immediately due and/or to demand advance payment or security for future deliveries and services.

3.4 The offsetting of counterclaims of the customer that are disputed by us and not legally established is excluded, as is the exercise of a right of retention by the customer.

## 4. Delivery:

4.1 The place of performance shall be our respective business premises in accordance with point 1. The risk shall pass to the customer as soon as the delivery item has been handed over to the carrier or other shipping person; in the event of default of acceptance by the customer as soon as shipment is ready.

4.2 Unless expressly agreed as binding, delivery periods are non-binding and are always to be understood as the expected time of provision and handover to the customer. Withdrawal from the contract by the customer due to delay in delivery is only possible by setting a reasonable - at least 4-week - grace period. The withdrawal must be asserted by registered letter. The right of withdrawal only refers to the part of delivery or service for which there is a delay. Subsequent requests for changes and additions by the customer shall extend the delivery time appropriately. The same shall apply in the event of unforeseen obstacles that lie outside our sphere or in the sphere of our supplier or in the event of force majeure.

4.3 In cases of delayed or non-executed delivery, claims for compensation of the customer are excluded even after the expiry of the grace period, except in cases of intent or gross negligence. In any case, our liability for damages caused by delay is limited to 0.5% of the value of the delayed delivery.

4.4 If a delivery is not possible due to delivery difficulties or price increases at our suppliers or at the manufacturer, we are entitled to withdraw from the contract without any obligation to pay compensation.

4.5 Goods not accepted on the agreed delivery date will be stored for a maximum of 6 weeks at the expense and risk of the customer. At the same time, we are entitled to insist on the fulfilment of the contract or, after setting a reasonable period of grace, to withdraw from the contract and use the goods for other purposes.

## 5. Reservation of ownership:

5.1 We reserve the right of ownership of the delivered goods until full payment of the purchase price as well as interest and costs arising from any delay in payment. The customer bears the entire risk (in particular destruction, loss, deterioration) for the goods subject to reservation of ownership. The customer is obliged to treat the goods with care during the existence of the reservation of ownership and to carry out all necessary maintenance and inspection work. In the event of treatment, processing or combination of the goods with other goods, our ownership extends to the new item/goods. Until the purchase price has been paid in full, the customer assigns to us on account of payment all claims and rights of security to which he is entitled from any resale. As soon as the reservation of ownership is asserted by us, the customer must refrain from any exploitation and, in the event of default of payment, we are entitled to inform the repurchasers of the goods, which the customer must inform us of, of the assignment and to demand payment to us.

5.2 Any pledging or assignment as security of the reserved goods is not permitted without our consent. The customer must notify us immediately of any pledging by third parties. In the event of the customer's insolvency, we shall be entitled to a corresponding right of separation.

The customer is obliged to inform us before filing for insolvency proceedings.

5.3 If it is necessary to make use of the reservation of ownership, the credit note for the returned goods will be issued taking into account a price reduction of at least 30% of the invoice value, which is appropriate to the duration of storage, wear and tear and other circumstances.

## 6. Construction and design:

6.1 Selection and dimensioning is determined by the customer's designer, as we do not know the design conditions such as the place and type of use. On request, we can assist with selection and dimensioning and prepare the assembly drawing and calculation for the customer on the basis of his performance parameters as a proposal. This drawing must be checked and approved by the customer. The drawing checked and approved by the customer is the basis for production and pre-assembly.

## 7. Technical changes during the term:

7.1 We are entitled to carry out technical changes after conclusion of the contract if the contractually agreed performance is not affected.

## 8. Notice of defects, warranty:

8.1 Defects must be reported in writing immediately after receipt of the delivery/service, at the latest within 14 days, hidden defects within 3 days of discovery. The complaint must be sufficiently substantiated and proven with documentary evidence. If the notification of defects is not made in due time, all warranty claims and claims for damages shall expire. In any case, the warranty right shall expire one year after delivery.

8.2 The existence of defects must be proven by the customer.

8.3 Minor technical changes as well as deviations from drawings and catalogues shall be deemed approved in advance.

8.4 In order to guarantee a safe function, a test run under load or real operation (according to the customer's design parameters) is necessary. We carry out our test runs in no-load operation, but not under load, with the customer's installation conditions. The test runs at the customer's premises are necessary to achieve a perfect installation geometry through exact assembly and to exclude function-interfering influences. We do not accept any liability for damage that is attributable to the fact that test runs under load or real operation are not carried out at the customer's premises. Furthermore, we do not assume any liability for the installation of our products in all types of vehicles on land, water and in the air, unless we have given written assurance to the contrary.

8.5 Insofar as this does not violate mandatory law and insofar as nothing else is regulated in these conditions, we shall only be liable for the compensation of damages which we have caused through gross negligence or intent. However, this limitation of liability does not apply to personal injury. We shall not be liable for indirect damage, lost profits, loss of interest, failure to make savings, consequential damage and damage to assets and damage from third-party claims.

8.6 Increased environmental impacts occur especially in outdoor use. In the event of a malfunction, we require a documented analysis of the cause - e.g. environmental influences or product defects. If the customer does not provide us with such a cause analysis, we are not obliged to remedy the defects. Warranty and damage claims are excluded in such case.

8.7 If a product delivered by us is indeed defect, it must be returned to us immediately - including error documentation/cause analysis. The customer's cause analysis is the basis for our laboratory checks and sustainable error avoidance. The transport costs are borne by the sender.

8.8 Liability for damage to property and personal injury due to product liability law is excluded. The customer undertakes to transfer this exclusion of liability to his customers.

## 9. IT:

9.1 If the customer makes use of electronic forms or e-mail for orders or other legal declarations, these require error-free access to us in order to be effective. Transmission errors shall be at the customer's risk without exception.

9.2 The data connected with our business relations (in particular name, address, telephone and fax numbers, e-mail addresses, order, delivery and invoice addresses, order data, ordered or delivered products and services, quantities, prices, delivery dates, payment and reminder data, etc.) are stored and processed in our IT system. The customer declares his consent to this.

## 10. Place of performance, applicable law:

10.1 The place of performance shall be our business premises in accordance with point 1. Austrian law shall apply exclusively, to the exclusion of the conflict of law rules of international private law and the UN Convention on Contracts for the International Sale of Goods (CISG).

10.2 All legal disputes arising between us and the customer in connection with a contractual relationship subject to these General Terms and Conditions shall be decided exclusively by the competent local court at our company's registered office (according to point 1).

## 11. Miscellaneous:

11.1 Should any provision of this contract be or become legally ineffective, invalid or void, this shall not affect the legal effectiveness and validity of the remaining provisions. In this case, the parties to the contract undertake to replace the legally ineffective, invalid or void provision with one that is legally effective and valid and corresponds to the replaced provision in its economic effect - as far as possible and legally permissible.

**YOUR INQUIRY  
IS OUR DRIVE**



**ZIMM GmbH**  
Millennium Park 3, A-6890 Lustenau, Vorarlberg  
**T** +43 5577 806-0, **E** info@zimm.com