

Bevel gearboxes ZK Series

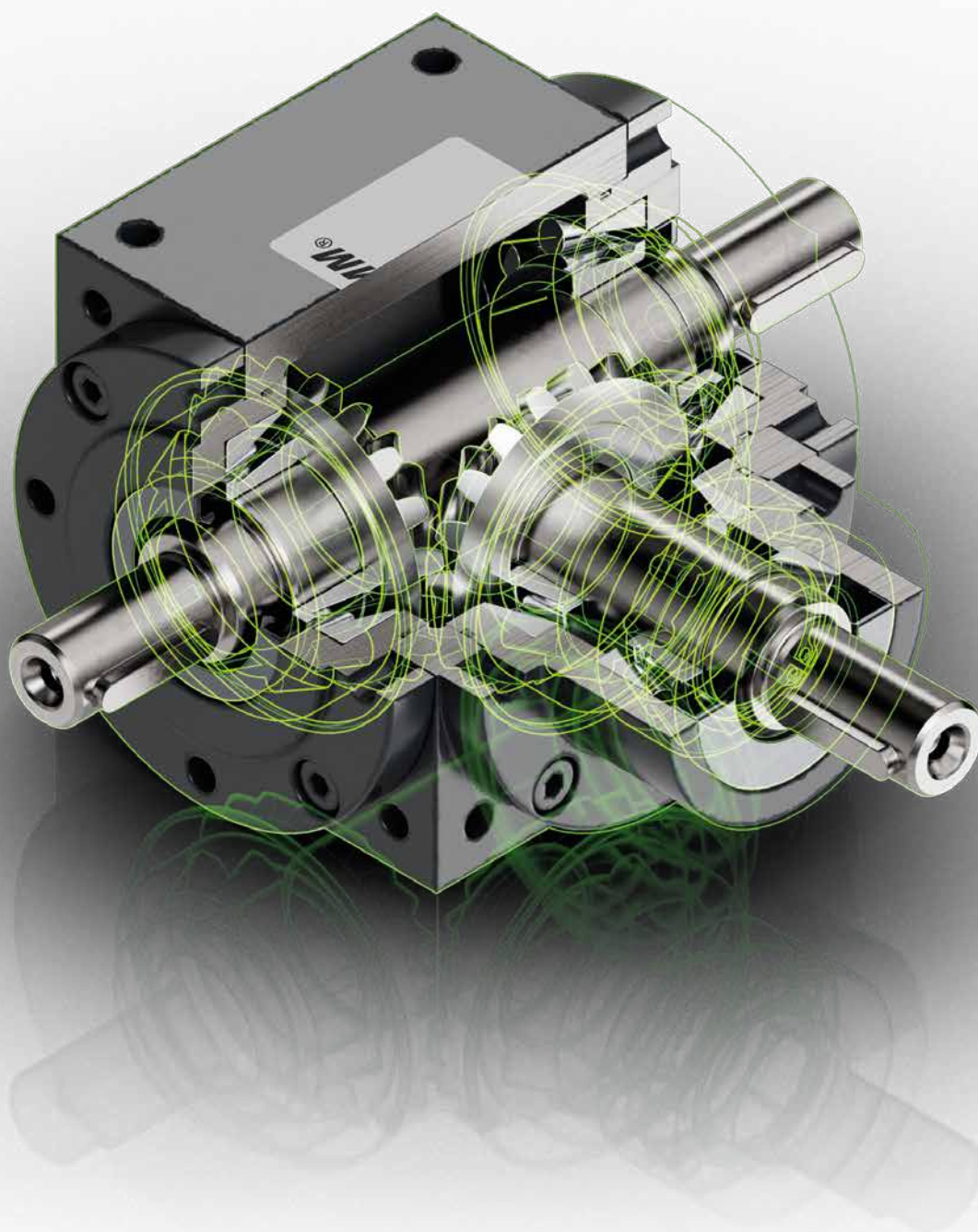



Table of contents

ZIMM Bevel gearboxes Product catalogue | 1.0

Features	4 – 7
Types / Gearbox versions / Side definition	9
Design	10 – 11
Speed limits	12
Bevel gearboxes	
Bevel gearbox size ZK-065	14 – 15
Bevel gearbox size ZK-090	16 – 17
Bevel gearbox size ZK-120	18 – 19
Bevel gearbox size ZK-140	20 – 21
Hollow shaft variant / Bearing cover	22 – 23
Order code	24
Technical information / Operation and maintenance	25
ZIMM modular system	26
ZIMM Builder	27

ZIMM Bevel gearboxes

Technology that gets it right



High service life

Designed for an operating life of over 20,000 hours – reliable even under demanding conditions.

Robust housing

Manufactured from high-quality grey cast iron, primed in RAL 7021 (black grey), shafts and sealing elements paint-free. Special coatings are available on request. Special version with additional paint-free areas available on request.

Versatile drive ratios

Available as standard in 1:1, 2:1 and 3:1 – further variants are already in development.

Proven lubrication

Filled with mineral lubricant for long-lasting performance and easy maintenance.



Power. Precision. Reliability. Rethought.

Since more than four decades, the name ZIMM has stood for the highest quality in drive technology. With our new bevel gearbox series, we consistently continue this claim – and further develop proven solutions technologically.

The result is a gearbox range that combines maximum performance with outstanding precision and uncompromising reliability.

Through complete machining of all housing faces, robust tapered-roller bearings and highly precise gearing, we set new standards for efficiency and smooth running. Optimized flank geometry and minimal torsional backlash enable maximum positioning accuracy and uniform power transmission – even in the most demanding applications.

Manufactured from high-quality materials and state of the art, our bevel gearboxes offer flexible mounting options and a long service life – for safe use in a wide range of industries and installation situations.

ZIMM bevel gearboxes: for all those who demand technical top performance and uncompromising quality.

ZIMM Bevel gearboxes

- 1 Grey cast-iron housing, machined on all faces**
Precise mechanical machining of all housing faces enables flexible mounting positions and highest precision fit
- 2 Robust tapered-roller bearing arrangement**
For maximum load capacity and long-term smooth running – ideal under high radial and axial forces
- 3 Shaft sealing by Form-A radial shaft seals¹**
Effective protection against dirt ingress and loss of lubricant (standard version in NBR)
- 4 Low torsional backlash**
Standard with torsional backlash of only 15 arcmin² – for high positioning accuracy in demanding applications
- 5 Bevel gears made of hardened steel with optimized flank geometry**
For quiet running, high efficiency and uniform power transmission
- 6 Shafts made of high-grade quenched-and-tempered steel**
Heat-treated for increased strength, wear resistance and long service life
- 7 Mounting threads on all sides**
Increase mounting options and allow easy integration into a wide range of installation situations

¹) also available in FPM on request. Alternatively: Form AS (with dust lip)
²) low-backlash version on request

Strong in detail – our bevel gearbox at a glance

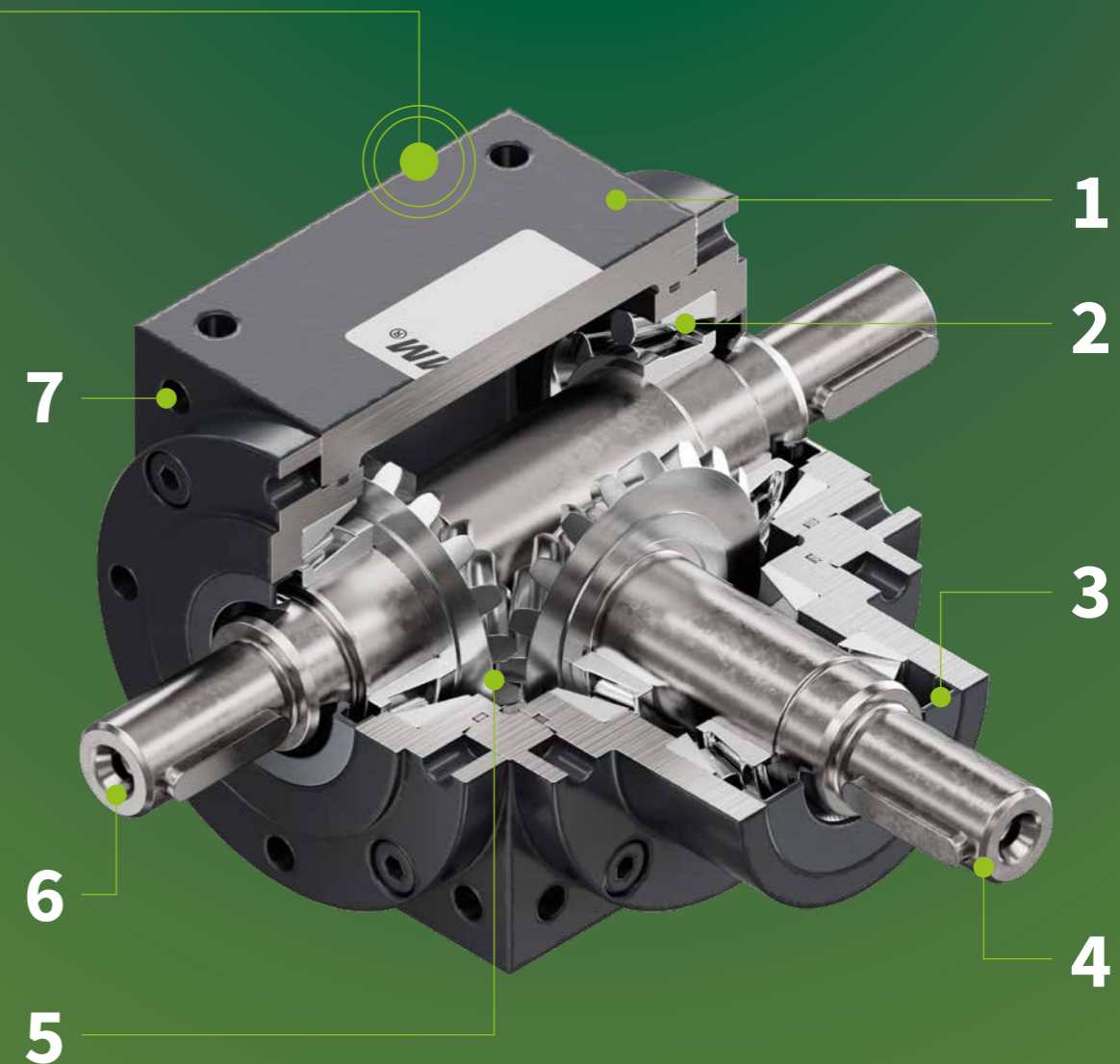



Types (Number and position of shafts)

1.1	1.2	1.3
Output shaft at bevel gear (side C)	Output shaft opposite to bevel gear (side A)	Output shaft on both sides (side A+C)
		

Versions

WE-FN	HW-FN
Drive shaft: solid shaft Output shaft: solid shaft	Drive shaft: solid shaft Output shaft: hollow shaft
	

Side definition

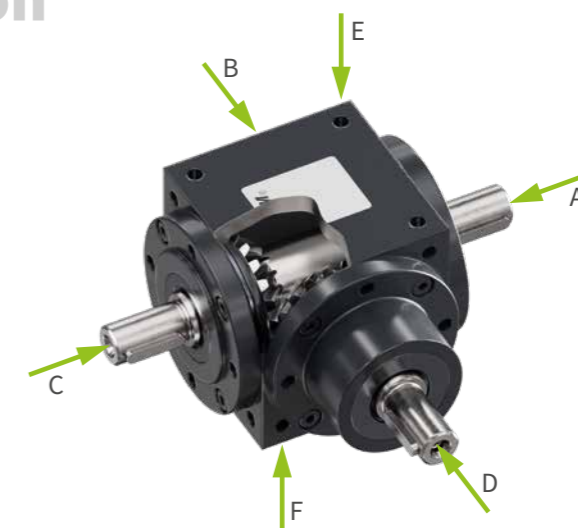



Design

Torque and speed:

at input (shaft D): $T_D = \frac{P_D \times 9550}{n_D}$

at output (shaft A / C): $T_{AC} = T_D \times i \times \eta$

$$P_{AC} = \frac{T_{AC} \times n_{AC}}{9550}$$

$$n_{AC} = \frac{n_D}{i}$$

Equivalent torque for load spectrum:

$$T_{AC} = \sqrt[6.6]{\frac{\sum (T_{AC;n}^{6.6} \times n_{AC;n} \times t_n)}{\sum (n_{AC;n} \times t_n)}}$$

$$n_{AC} = \frac{\sum n_{AC;n} \times t_n}{\sum t_n}$$

Rated torque / rated power for gearbox selection:

$$T_{a;AC} = T_{AC} \times f_b \times f_t \times f_d$$

$$P_a = P_{AC} \times f_b \times f_t \times f_d$$

Thermal limit power:

$$P_t = P_{AC} \times f_d \times f_t \times f_e$$

A breather is required from 80% P_t!

The derivation of the factors is described on the following pages



Explanations:

T_D Input torque [Nm]
P_D Input power [kW]
n_D Input speed [min⁻¹]

T_{AC} Output torque [Nm]
P_{AC} Output power [kW]
n_{AC} Output speed [min⁻¹]
i Drive ratio
η Gearbox efficiency

T_{AC;n} Output torque of a load case [Nm]
n_{AC;n} Output speed of a load case [min⁻¹]
t_n Time share of a load case [min⁻¹]

T_{a;AC} Design torque at the output [Nm]
P_a Design power at the gearbox [kW]
P_t Thermal limit power [kW]
f_b Operating factor
f_t Temperature factor
f_d Speed factor
f_e Duty factor

Application case III (ka ≤ 10,0)
 Application case II (ka ≤ 3,0)
 Application case I (ka ≤ 0,25)

Example calculation:

Initial situation:

Three-phase motor for fan, with 0.75 kW, 1390 rpm, operation 16 h/d, max. 100% ED/10 min, max. 100 starts / hour, fan speed 500–750 rpm, 20°C ambient temperature, 350 N radial force at output shaft

Selected: Bevel gearbox with drive ratio 2:1

1) Input: $T_D = \frac{0,75 \text{ kW} \times 9550}{1390 \text{ min}^{-1}} = 5,15 \text{ Nm}$

2) Output: $T_{AC} = 5,15 \text{ Nm} \times \frac{2}{1} \times 0,97 = 10,0 \text{ Nm}$

$$P_{AC} = \frac{10,0 \text{ Nm} \times 695 \text{ min}^{-1}}{9550} = 0,73 \text{ kW}$$

3) Including factors for gearbox selection:
 f_b = 1,1 (application case I, 16 h/d, 100 c/h)
 f_d = 1,15 (n_D 1000..1700)
 f_t = 1,0 (20°C)
 f_e = 1,0 (100% ED/10 min)

$$T_{a;AC} = 10,0 \text{ Nm} \times 1,1 \times 1,15 \times 1,0 = \mathbf{12,65 \text{ Nm}}$$

$$P_t = 0,73 \text{ kW} \times 1,15 \times 1,0 \times 1,0 = \mathbf{0,84 \text{ kW}}$$

4) Gearbox selection:

Comparison of calculated values with permissible values according to tables

T_{a;AC}: 12,65 Nm < 14,5 Nm ✓
 F_{r;AC}: 350 N < 390 N ✓
 P_t: 0,84 kW < 1,3 kW ✓
 P_t: 0,84 kW < 1,04 kW (= 1,3 kW x 80%) ✓

→ **ZK-065-2:1**, without breather

Determining the operating factor f_b for 8 h/d operating time

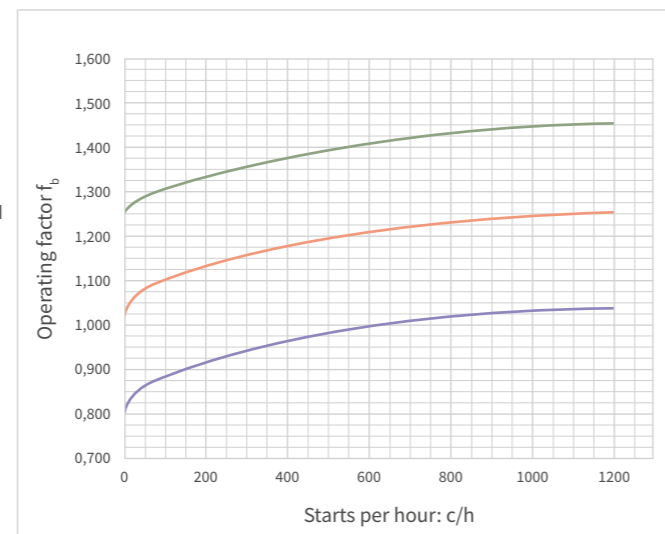

Design

Factors:

Operating factor f_b

Derivation: 1) Select the appropriate application case
 2) Select the diagram according to the duty factor
 3) Enter the switching frequency per hour on the x-axis and read off the operating factor

smooth, shock-free operation low accelerations	irregular, shock-loaded operation medium accelerations	highly irregular operation, heavy shocks, high accelerations, alternating load
Application case I (ka ≤ 0,25)	Application case II (ka ≤ 3,0)	Application case III (ka ≤ 10,0)
Filling machines Elevators, light-duty Screw conveyors, light-duty Fans Lifting platforms Mixers, light-duty Roller grilles Conveyor belts, light-duty Packaging machines Workpiece drives Centrifuges	Rotary table drives Elevators, heavy-duty Reels Kneading machines Mixers, heavy-duty Mills Agitators, light-duty Gate drives Conveyor belts, heavy-duty Packaging machines Winches	Crushers Calenders Press brakes Piston pumps Presses Agitators, heavy-duty Vibrators Shears Punching machines Rolling mills Cement mills

Speed factor f_d

Input speed n _D [min ⁻¹]	0..500	500..1000	1000..1700	1700..2400	2400..3000
Speed factor f _d	0,90	1,00	1,15	1,23	1,30

Temperature factor f_t

Ambient temperature [°C]	10	15	20	25	30	35	40	45	50
Temperature factor f _t	0,90	0,95	1,00	1,10	1,20	1,30	1,40	1,50	1,60

Duty factor f_e

max. duty factor [% / 10 min]	100	80	60	40	20	10
Duty factor f _e	1,00	0,95	0,80	0,60	0,30	0,15

Determining the operating factor f_b for 16 h/d operating time

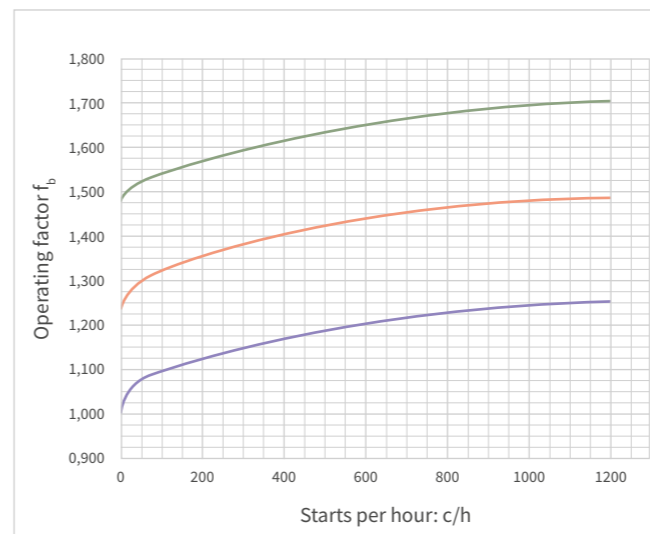

Determining the operating factor f_b for 24 h/d operating time

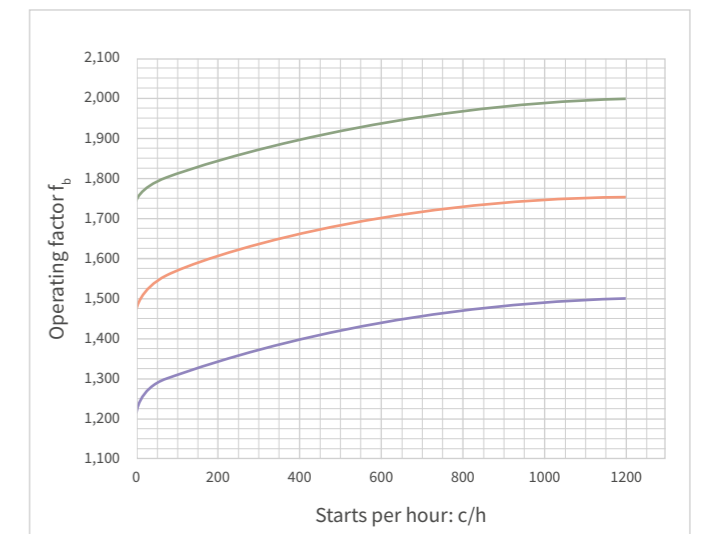

Speed limits

maximum input speed n_b with standard lubricant

Mounting orientation shafts		i	ZK-065	ZK-090	ZK-120	ZK-140
		$n_b : n_{AC}$	n_b, min^{-1}	n_b, min^{-1}	n_b, min^{-1}	n_b, min^{-1}
	all horizontal / input below (shaft D)	1:1	1800	1800	1800	1800
		2:1	1800	1800	1800	1800
		3:1	1800	1800	1800	1800
	input above (shaft D)	1:1	1800	1800	1700	1550
		2:1	1800	1800	1700	1550
		3:1	1800	1800	1700	1550
	output vertical (shaft A/C)	1:1	1800	1800	1700	1460
		2:1	1800	1800	1800	1800
		3:1	1800	1800	1800	1800

maximum input speed n_b with high-performance lubricant

Mounting orientation shafts		i	ZK-065	ZK-090	ZK-120	ZK-140
		$n_b : n_{AC}$	n_b, min^{-1}	n_b, min^{-1}	n_b, min^{-1}	n_b, min^{-1}
	all horizontal / input below (shaft D)	1:1	3000	3000	3000	3000
		2:1	3000	3000	3000	3000
		3:1	3000	3000	3000	3000
	input above (shaft D)	1:1	3000	2200	-	-
		2:1	3000	2200	-	-
		3:1	3000	2200	-	-
	output vertical (shaft A/C)	1:1	3000	2200	-	-
		2:1	3000	3000	3000	2800
		3:1	3000	3000	3000	3000



065

ZK-065 | Bevel gearboxes

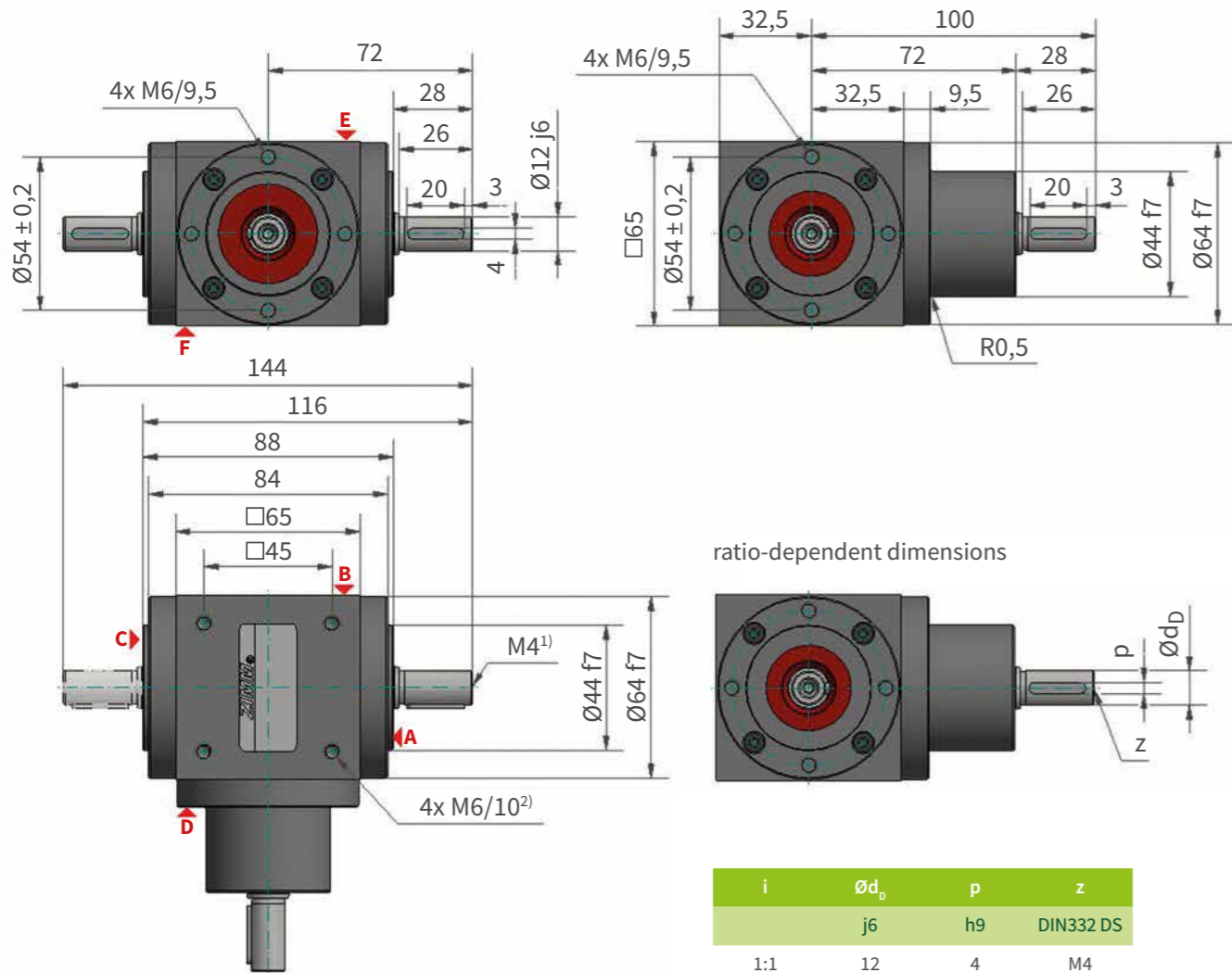

ratio-dependent dimensions

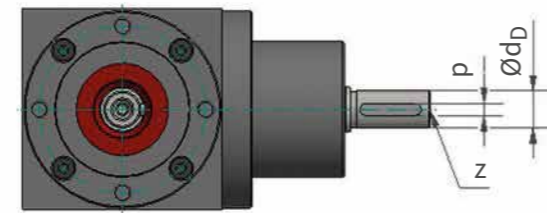

i	Ød _b	p	z
	j6	h9	DIN332 DS
1:1	12	4	M4
2:1	12	4	M4
3:1	12	4	M4

1) Shaft center holes according to DIN 332 DS
2) Mounting holes M6 on housing side B, E and F

Technical data

Available drive ratios:	3:1 / 2:1 / 1:1
Further types of construction:	HW (hollow shaft)
Efficiency:	0,97
Moment of inertia:	40,0 / 48,4 kgmm ² (Solid shaft / HW; 1:1) 23,6 / 25,8 kgmm ² (Solid shaft / HW; 2:1) 13,6 / 14,6 kgmm ² (Solid shaft / HW; 3:1)
Weight ¹ :	2,4 kg
Housing material:	Cast iron, corrosion-protected
Shaft material:	Quenched-and-tempered steel
Lubrication:	mineral lubricating oil
Max. drive:	3000 rpm
Max. drive, shaft upward ² :	3000 rpm (shaft D; x:1) 3000 rpm (shaft A, C; 1:1) 3000 rpm (shaft A, C; 2:1 / 3:1)
Seals:	NBR ³
Shaft seals:	Form A ⁴
Drive keys:	DIN 6885-1 Form A

General further information

Dimensions for hollow shaft, see page 22.

Illustration with bearing cover R; bearing cover Q is not available for size 065.

Important notes

- For type 1.1 / 1.2 / 1.3 / 1.3-HW
- For installation situation with vertical shaft, observe speed limitation
- Alternative materials on request
- Form AS for high dirt loads on request

Torques and side forces

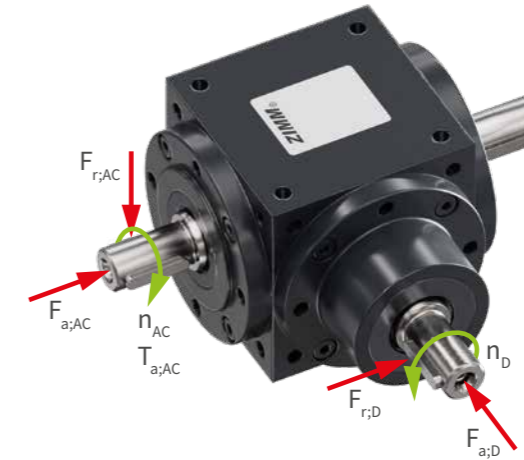

i	n _D	n _{AC}	P _a	P _t ¹⁾	T _{a,AC}	F _{a,D}	F _{r,D}	F _{a,AC}	F _{r,AC}
n _D : n _{AC}	min ⁻¹	min ⁻¹	kW	kW	Nm	N	N	N	N
1:1	50	50	0,09	1,3	18,00	420	570	700	950
	100	100	0,19	1,3	18,00	350	480	550	800
	250	250	0,46	1,3	17,50	270	370	450	700
	500	500	0,92	1,3	17,50	230	320	400	550
	750	750	1,37	1,3	17,50	200	280	310	480
	1000	1000	1,78	1,3	17,00	180	260	240	420
	1500	1500	2,36	1,3	15,00	160	230	200	390
	2000	2000	2,83	1,3	13,50	150	210	190	370
	2400	2400	3,27	1,3	13,00	140	200	170	350
3000	3000	3,77	1,3	12,00	130	180	160	340	

i	n _D	n _{AC}	P _a	P _t ¹⁾	T _{a,AC}	F _{a,D}	F _{r,D}	F _{a,AC}	F _{r,AC}
n _D : n _{AC}	min ⁻¹	min ⁻¹	kW	kW	Nm	N	N	N	N
2:1	50	25	0,04	1,3	16,50	420	570	700	950
	100	50	0,09	1,3	16,50	350	480	550	800
	250	125	0,22	1,3	16,50	270	370	450	700
	500	250	0,41	1,3	15,50	230	320	400	550
	750	375	0,59	1,3	15,00	200	280	310	480
	1000	500	0,79	1,3	15,00	180	260	240	420
	1500	750	1,14	1,3	14,50	160	230	200	390
	2000	1000	1,52	1,3	14,50	150	210	190	370
	2400	1200	1,82	1,3	14,50	140	200	170	350
3000	1500	2,28	1,3	14,50	130	180	160	340	

i	n _D	n _{AC}	P _a	P _t ¹⁾	T _{a,AC}	F _{a,D}	F _{r,D}	F _{a,AC}	F _{r,AC}
n _D : n _{AC}	min ⁻¹	min ⁻¹	kW	kW	Nm	N	N	N	N
3:1	50	17	0,02	1,3	14,00	420	570	700	950
	100	33	0,05	1,3	14,00	350	480	550	800
	250	83	0,12	1,3	13,50	270	370	450	700
	500	167	0,24	1,3	13,50	230	320	400	550
	750	250	0,34	1,3	13,00	200	280	310	480
	1000	333	0,45	1,3	13,00	180	260	240	420
	1500	500	0,68	1,3	13,00	160	230	200	390
	2000	667	0,87	1,3	12,50	150	210	190	370
	2400	800	1,01	1,3	12,00	140	200	170	350
3000	1000	1,20	1,3	11,50	130	180	160	340	

1) For S1 operation, clean indoor installation and 20°C ambient temperature

090

ZK-090 | Bevel gearboxes

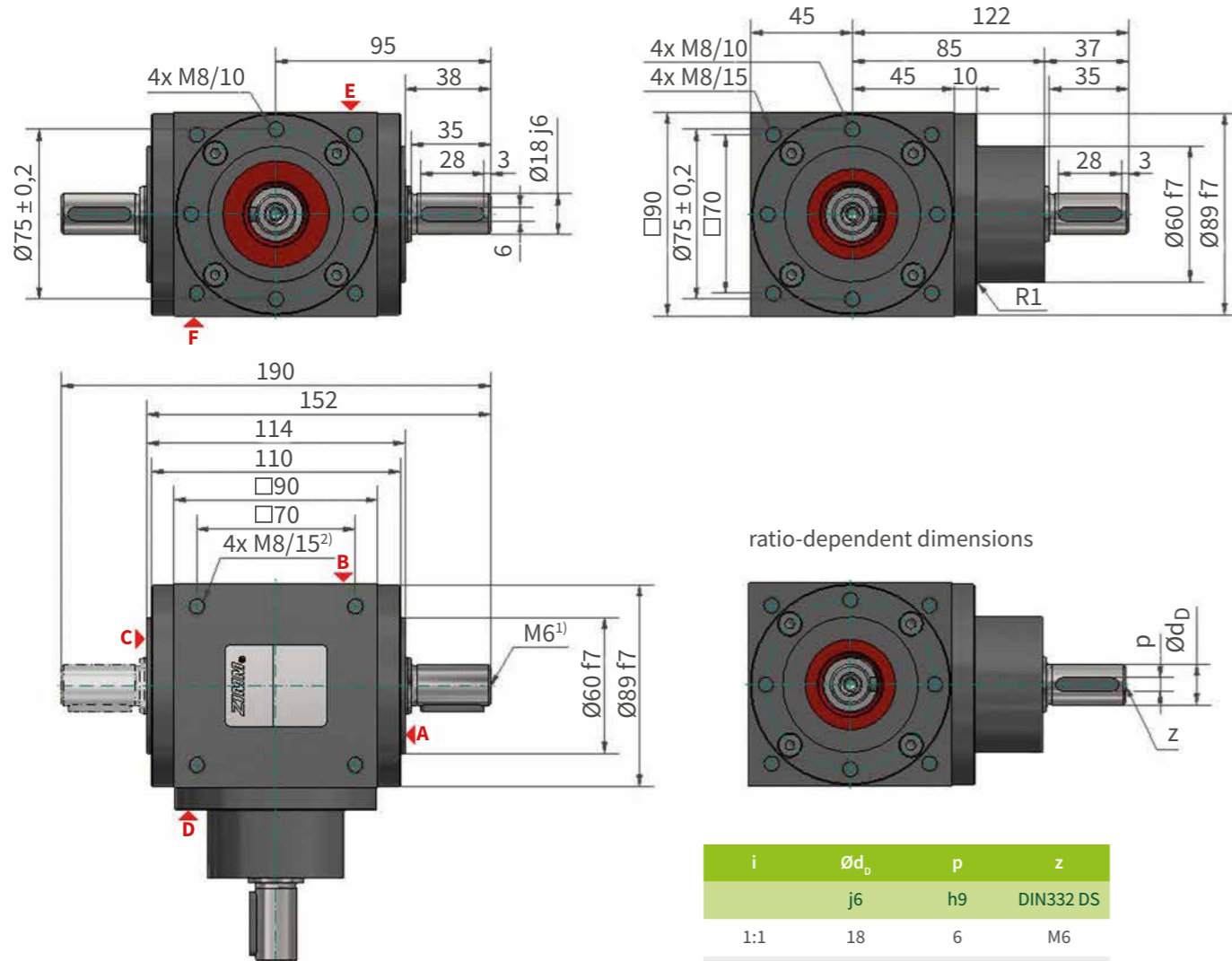

i	Ød _b	p	z
	j6	h9	DIN332 DS
1:1	18	6	M6
2:1	18	6	M6
3:1	12	4	M4

1) Shaft center holes according to DIN 332 DS
2) Mounting holes M8 on all 6 housing sides

Technical data

Available drive ratios:	3:1 / 2:1 / 1:1
Further types of construction:	HW (hollow shaft)
Efficiency:	0,97
Moment of inertia:	306 / 297 kgmm ² (Solid shaft / HW; 1:1) 133 / 131 kgmm ² (Solid shaft / HW; 2:1) 54,4 / 53,5 kgmm ² (Solid shaft / HW; 3:1)
Weight ¹ :	5,5 kg
Housing material:	Cast iron, corrosion-protected
Shaft material:	Quenched-and-tempered steel
Lubrication:	mineral lubricating oil
Max. drive:	3000 rpm
Max. drive, shaft upward ² :	2200 rpm (shaft D; x:1) 2200 rpm (shaft A, C; 1:1) 3000 rpm (shaft A, C; 2:1 / 3:1)
Seals:	NBR ³
Shaft seals:	Form A ⁴
Drive keys:	DIN 6885-1 Form A

General further information

Dimensions for hollow shaft, see page 22.

Illustration with bearing cover R;
dimensions for bearing cover Q, see page 23.

Important notes

- For type 1.1 / 1.2 / 1.3 / 1.3-HW
- For installation situation with vertical shaft, observe speed limitation
- Alternative materials on request
- Form AS for high dirt loads on request

Torques and side forces

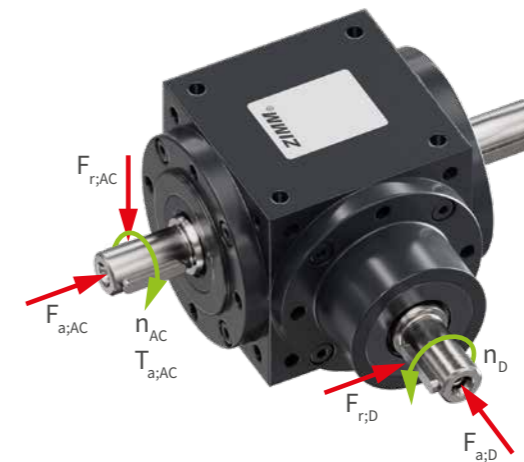

i	n _D	n _{AC}	P _a	P _t ¹⁾	T _{a;AC}	F _{a;D}	F _{r;D}	F _{a;AC}	F _{r;AC}
n _D : n _{AC}	min ⁻¹	min ⁻¹	kW	kW	Nm	N	N	N	N
1:1	50	50	0,28	2,35	53	650	880	1100	1500
	100	100	0,55	2,35	53	500	700	900	1400
	250	250	1,36	2,35	52	400	570	690	1000
	500	500	2,51	2,35	48	340	460	570	820
	750	750	3,38	2,35	43	280	430	520	730
	1000	1000	4,19	2,35	40	250	360	460	700
	1500	1500	5,50	2,35	35	240	320	420	620
	2000	2000	6,70	2,35	32	205	315	390	590
	2400	2400	7,54	2,35	30	180	310	370	550
3000	3000	8,80	2,35	28	170	300	350	500	

i	n _D	n _{AC}	P _a	P _t ¹⁾	T _{a;AC}	F _{a;D}	F _{r;D}	F _{a;AC}	F _{r;AC}
n _D : n _{AC}	min ⁻¹	min ⁻¹	kW	kW	Nm	N	N	N	N
2:1	50	25	0,14	2,35	52	650	880	1100	1500
	100	50	0,27	2,35	51	500	700	900	1400
	250	125	0,64	2,35	49	400	570	690	1000
	500	250	1,26	2,35	48	340	460	570	820
	750	375	1,85	2,35	47	280	430	520	730
	1000	500	2,41	2,35	46	250	360	460	700
	1500	750	3,46	2,35	44	240	320	420	620
	2000	1000	4,40	2,35	42	205	315	390	590
	2400	1200	5,03	2,35	40	180	310	370	550
3000	1500	5,81	2,35	37	170	300	350	500	

i	n _D	n _{AC}	P _a	P _t ¹⁾	T _{a;AC}	F _{a;D}	F _{r;D}	F _{a;AC}	F _{r;AC}
n _D : n _{AC}	min ⁻¹	min ⁻¹	kW	kW	Nm	N	N	N	N
3:1	50	17	0,07	2,35	41	650	880	1100	1500
	100	33	0,14	2,35	40	500	700	900	1400
	250	83	0,34	2,35	39	400	570	690	1000
	500	167	0,66	2,35	38	340	460	570	820
	750	250	0,97	2,35	37	280	430	520	730
	1000	333	1,26	2,35	36	250	360	460	700
	1500	500	1,83	2,35	35	240	320	420	620
	2000	667	2,30	2,35	33	205	315	390	590
	2400	800	2,60	2,35	31	180	310	370	550
3000	1000	3,14	2,35	30	170	300	350	500	

1) For S1 operation, clean indoor installation and 20°C ambient temperature

120

ZK-120 | Bevel gearboxes

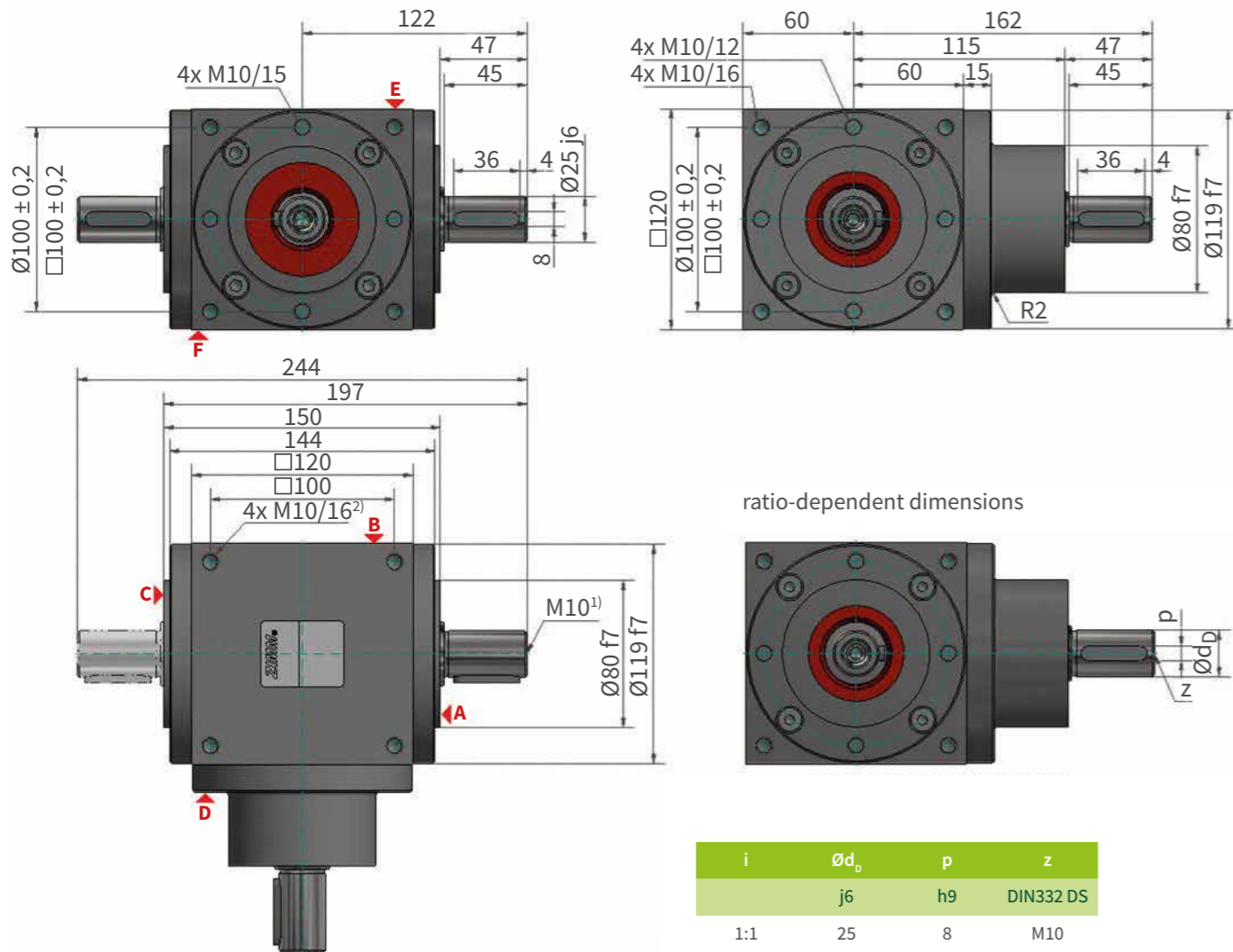

1) Shaft center holes according to DIN 332 DS
2) Mounting holes M10 on all 6 housing sides

Technical data

Available drive ratios:	3:1 / 2:1 / 1:1
Further types of construction:	HW (hollow shaft)
Efficiency:	0,97
Moment of inertia:	1285 / 1232 kgmm ² (Solid shaft / HW; 1:1) 655 / 642 kgmm ² (Solid shaft / HW; 2:1) 288 / 282 kgmm ² (Solid shaft / HW; 3:1)
Weight ¹⁾ :	13,6 kg
Housing material:	Cast iron, corrosion-protected
Shaft material:	Quenched-and-tempered steel
Lubrication:	mineral lubricating oil
Max. drive:	3000 rpm
Max. drive, shaft upward ²⁾ :	1700 rpm (shaft D; x:1) 1700 rpm (shaft A, C; 1:1) 3000 rpm (shaft A, C; 2:1 / 3:1)
Seals:	NBR ³⁾
Shaft seals:	Form A ⁴⁾
Drive keys:	DIN 6885-1 Form A

General further information

Dimensions for hollow shaft, see page 22.
Illustration with bearing cover R;
dimensions for bearing cover Q, see page 23.

Important notes

- For type 1.1 / 1.2 / 1.3 / 1.3-HW
- For installation situation with vertical shaft, observe speed limitation
- Alternative materials on request
- Form AS for high dirt loads on request

Torques and side forces

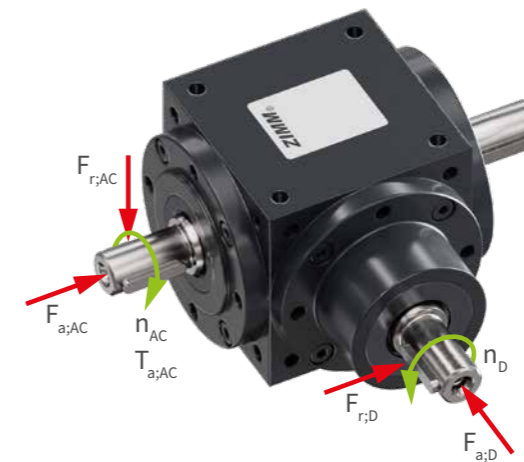

i	n _D	n _{AC}	P _a	P _t ¹⁾	T _{a;AC}	F _{a;D}	F _{r;D}	F _{a;AC}	F _{r;AC}
n _D : n _{AC}	min ⁻¹	min ⁻¹	kW	kW	Nm	N	N	N	N
1:1	50	50	0,71	4,1	135	1000	1400	1600	2200
	100	100	1,36	4,1	130	850	1200	1350	2000
	250	250	3,27	4,1	125	650	900	1050	1600
	500	500	6,02	4,1	115	520	700	850	1300
	750	750	8,25	4,1	105	480	670	730	1150
	1000	1000	9,95	4,1	95	440	620	690	1000
	1500	1500	13,35	4,1	85	400	560	630	900
	2000	2000	16,13	4,1	77	370	520	590	800
	2400	2400	18,35	4,1	73	350	470	550	750
3000	3000	21,99	4,1	70	320	440	500	700	

i	n _D	n _{AC}	P _a	P _t ¹⁾	T _{a;AC}	F _{a;D}	F _{r;D}	F _{a;AC}	F _{r;AC}
n _D : n _{AC}	min ⁻¹	min ⁻¹	kW	kW	Nm	N	N	N	N
2:1	50	25	0,31	4,1	120	1000	1400	1600	2200
	100	50	0,63	4,1	120	850	1200	1350	2000
	250	125	1,54	4,1	118	650	900	1050	1600
	500	250	3,01	4,1	115	520	700	850	1300
	750	375	4,40	4,1	112	480	670	730	1150
	1000	500	5,65	4,1	108	440	620	690	1000
	1500	750	7,54	4,1	96	400	560	630	900
	2000	1000	9,42	4,1	90	370	520	590	800
	2400	1200	10,81	4,1	86	350	470	550	750
3000	1500	12,72	4,1	81	320	440	500	700	

i	n _D	n _{AC}	P _a	P _t ¹⁾	T _{a;AC}	F _{a;D}	F _{r;D}	F _{a;AC}	F _{r;AC}
n _D : n _{AC}	min ⁻¹	min ⁻¹	kW	kW	Nm	N	N	N	N
3:1	50	17	0,17	4,1	97	1000	1400	1600	2200
	100	33	0,32	4,1	92	850	1200	1350	2000
	250	83	0,79	4,1	91	650	900	1050	1600
	500	167	1,57	4,1	90	520	700	850	1300
	750	250	2,28	4,1	87	480	670	730	1150
	1000	333	2,97	4,1	85	440	620	690	1000
	1500	500	4,19	4,1	80	400	560	630	900
	2000	667	5,24	4,1	75	370	520	590	800
	2400	800	6,03	4,1	72	350	470	550	750
3000	1000	7,12	4,1	68	320	440	500	700	

1) For S1 operation, clean indoor installation and 20°C ambient temperature

140

ZK-140 | Bevel gearboxes

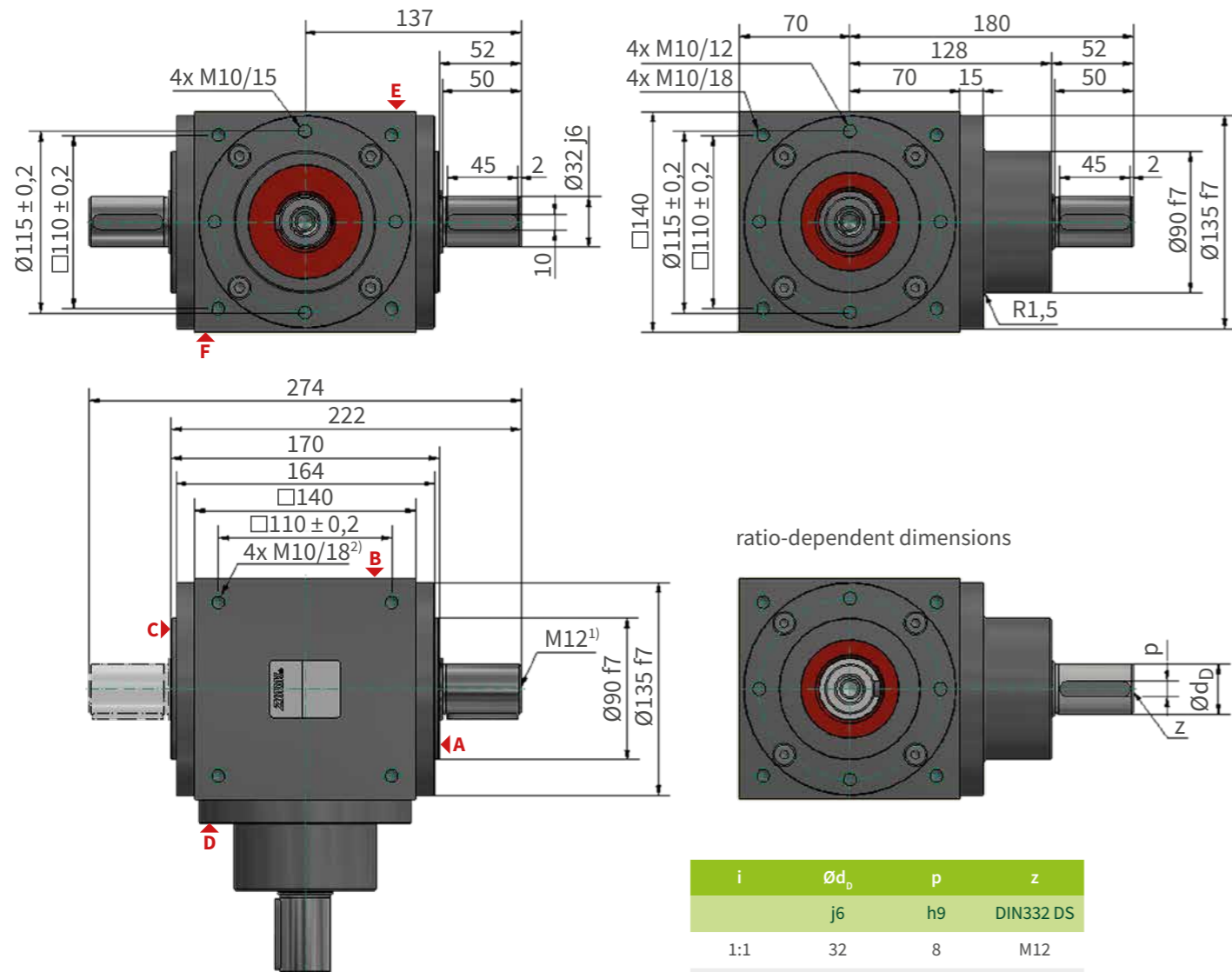

i	Ød _b	p	z
	j6	h9	DIN332 DS
1:1	32	8	M12
2:1	32	8	M12
3:1	28	7	M10

1) Shaft center holes according to DIN 332 DS
2) Mounting holes M10 on all 6 housing sides

Technical data

Available drive ratios:	3:1 / 2:1 / 1:1
Further types of construction:	HW (hollow shaft)
Efficiency:	0,97
Moment of inertia:	2452 / 2255 kgmm ² (Solid shaft / HW; 1:1) 1248 / 1200 kgmm ² (Solid shaft / HW; 2:1) 781 / 760 kgmm ² (Solid shaft / HW; 3:1)
Weight ¹ :	20,1 kg
Housing material:	Cast iron, corrosion-protected
Shaft material:	Quenched-and-tempered steel
Lubrication:	mineral lubricating oil
Max. drive:	3000 rpm
Max. drive, shaft upward ² :	1550 rpm (shaft D; x:1) 1460 rpm (shaft A, C; 1:1) 2800 rpm (shaft A, C; 2:1) 3000 rpm (shaft A, C; 3:1)
Seals:	NBR ³
Shaft seals:	Form A ⁴
Drive keys:	DIN 6885-1 Form A

General further information

Dimensions for hollow shaft, see page 22.

Illustration with bearing cover R;
dimensions for bearing cover Q, see page 23.

Important notes

- For type 1.1 / 1.2 / 1.3 / 1.3-HW
- For installation situation with vertical shaft, observe speed limitation
- Alternative materials on request
- Form AS for high dirt loads on request

Torques and side forces

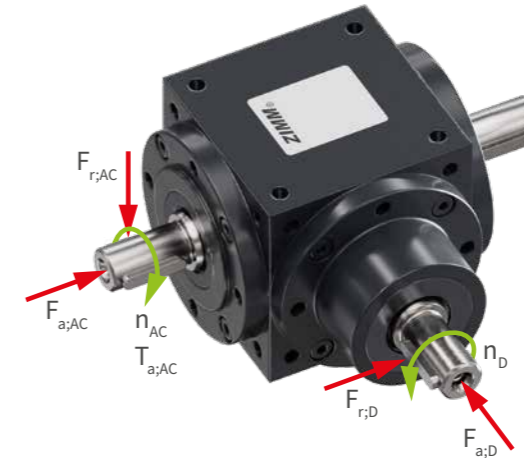

i	n _D	n _{AC}	P _a	P _t ¹⁾	T _{a,AC}	F _{a,D}	F _{r,D}	F _{a,AC}	F _{r,AC}
n _D : n _{AC}	min ⁻¹	min ⁻¹	kW	kW	Nm	N	N	N	N
1:1	50	50	1,05	5,4	200	1550	2100	2550	3900
	100	100	2,09	5,4	200	1300	1900	2100	3100
	250	250	4,97	5,4	190	1050	1450	1600	2600
	500	500	9,69	5,4	185	850	1100	1300	2050
	750	750	12,96	5,4	165	700	950	1200	1850
	1000	1000	16,02	5,4	153	610	870	1100	1700
	1500	1500	21,52	5,4	137	490	790	1050	1550
	2000	2000	26,18	5,4	125	450	740	1000	1450
2:1	2400	2400	29,65	5,4	118	430	720	950	1350
	3000	3000	34,55	5,4	110	410	680	900	1300

i	n _D	n _{AC}	P _a	P _t ¹⁾	T _{a,AC}	F _{a,D}	F _{r,D}	F _{a,AC}	F _{r,AC}
n _D : n _{AC}	min ⁻¹	min ⁻¹	kW	kW	Nm	N	N	N	N
1:1	50	25	0,52	5,4	200	1550	2100	2550	3900
	100	50	1,05	5,4	200	1300	1900	2100	3100
	250	125	2,49	5,4	190	1050	1450	1600	2600
	500	250	4,71	5,4	180	850	1100	1300	2050
	750	375	6,36	5,4	162	700	950	1200	1850
	1000	500	7,85	5,4	150	610	870	1100	1700
	1500	750	10,52	5,4	134	490	790	1050	1550
	2000	1000	12,77	5,4	122	450	740	1000	1450
2:1	2400	1200	14,45	5,4	115	430	720	950	1350
	3000	1500	16,49	5,4	105	410	680	900	1300

i	n _D	n _{AC}	P _a	P _t ¹⁾	T _{a,AC}	F _{a,D}	F _{r,D}	F _{a,AC}	F _{r,AC}
n _D : n _{AC}	min ⁻¹	min ⁻¹	kW	kW	Nm	N	N	N	N
1:1	50	17	0,31	5,4	175	1550	2100	2550	3900
	100	33	0,60	5,4	173	1300	1900	2100	3100
	250	83	1,48	5,4	170	1050	1450	1600	2600
	500	167	2,79	5,4	160	850	1100	1300	2050
	750	250	3,93	5,4	150	700	950	1200	1850
	1000	333	5,06	5,4	145	610	870	1100	1700
	1500	500	7,17	5,4	137	490	790	1050	1550
	2000	667	9,08	5,4	130	450	740	1000	1450
2:1	2400	800	10,22	5,4	122	430	720	950	1350
	3000	1000	11,94	5,4	114	410	680	900	1300

1) For S1 operation, clean indoor installation and 20°C ambient temperature

Variant

Hollow shaft | Bevel gearbox 1.3 / HW

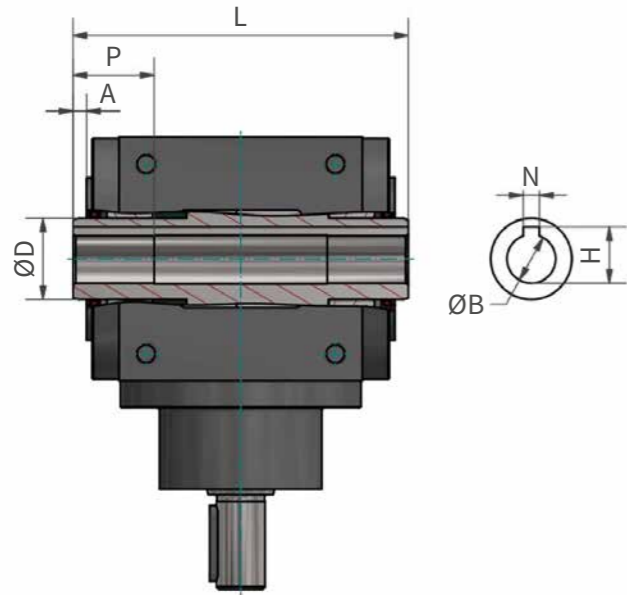

Keyway according to DIN 6885-1.
The dimensions listed are identical for all available drive ratios.
Dimensions not listed correspond to those of the standard type of construction.
For moments of inertia, see the standard type of construction.

ZK	ØB	H	N	P	ØD	A	L
	H7	+0,1	JS9				DIN ISO 2768-m
065	12	13,8	4	20	20	2	92
090	18	20,8	6	30	30	5	124
120	25	28,3	8	40	40	5	160
140	32	35,3	10	50	45	5	180



Variant

Square bearing cover | Bevel gearbox Q

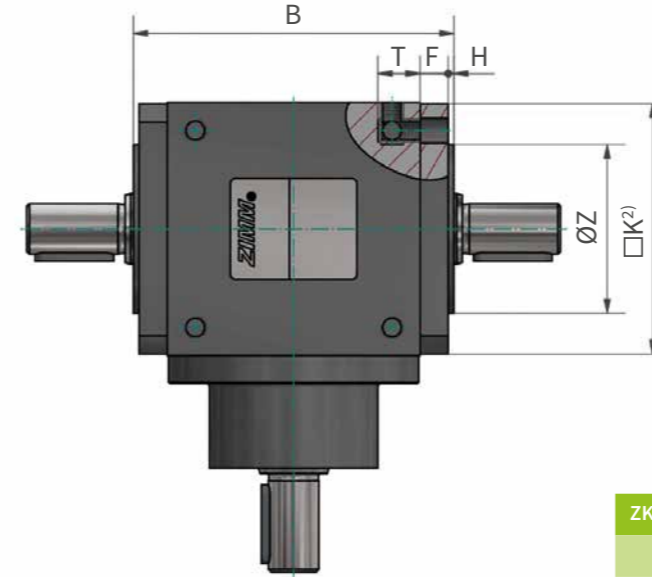

ZK ¹⁾	□K ²⁾	ØZ	H	□L	ØD ²⁾	F	G	T	T+F ²⁾	B	ØR ²⁾
		f7									
090	89	60	2	70	9	10	M8	15	25	114	117
120	119	80	3	100	11	12	M10	16	28	150	164
140	139	100	3	110	11	12	M10	18	30	170	192

1) Bearing cover Q is not available for size 065.
2) These dimensions are only present with bearing cover Q.
All other dimensions, as well as dimensions not listed, correspond to those of the standard type of construction with bearing cover R.

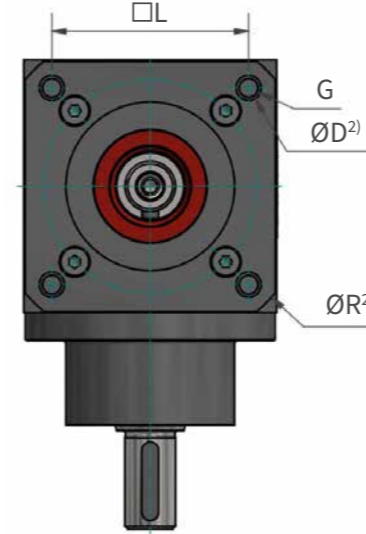

Order code

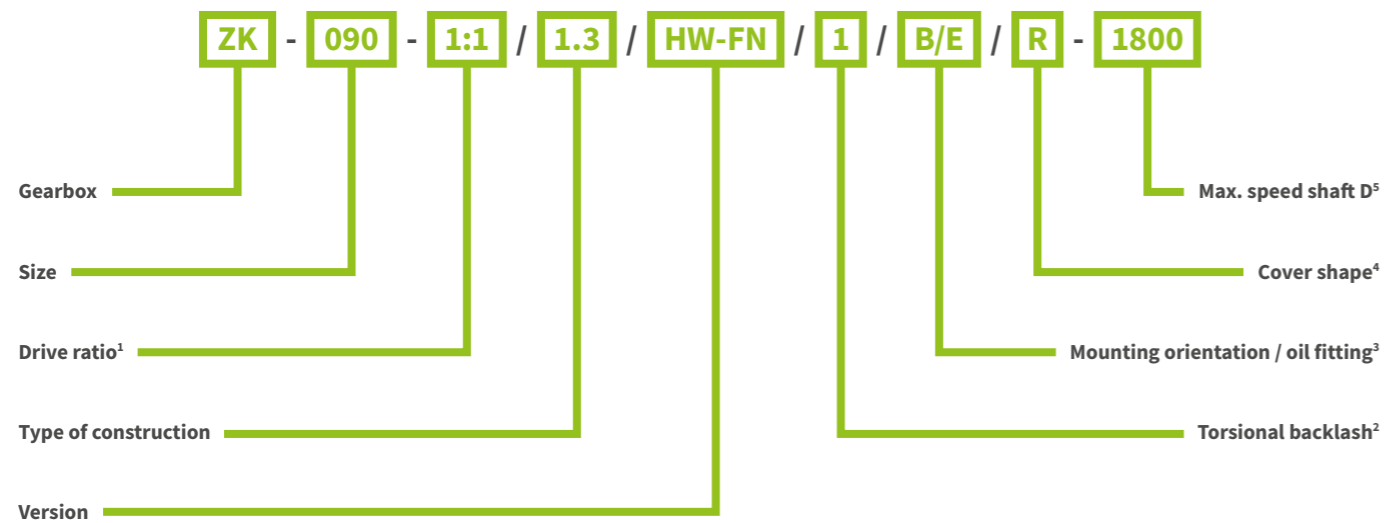

ZK- .. Gearbox series

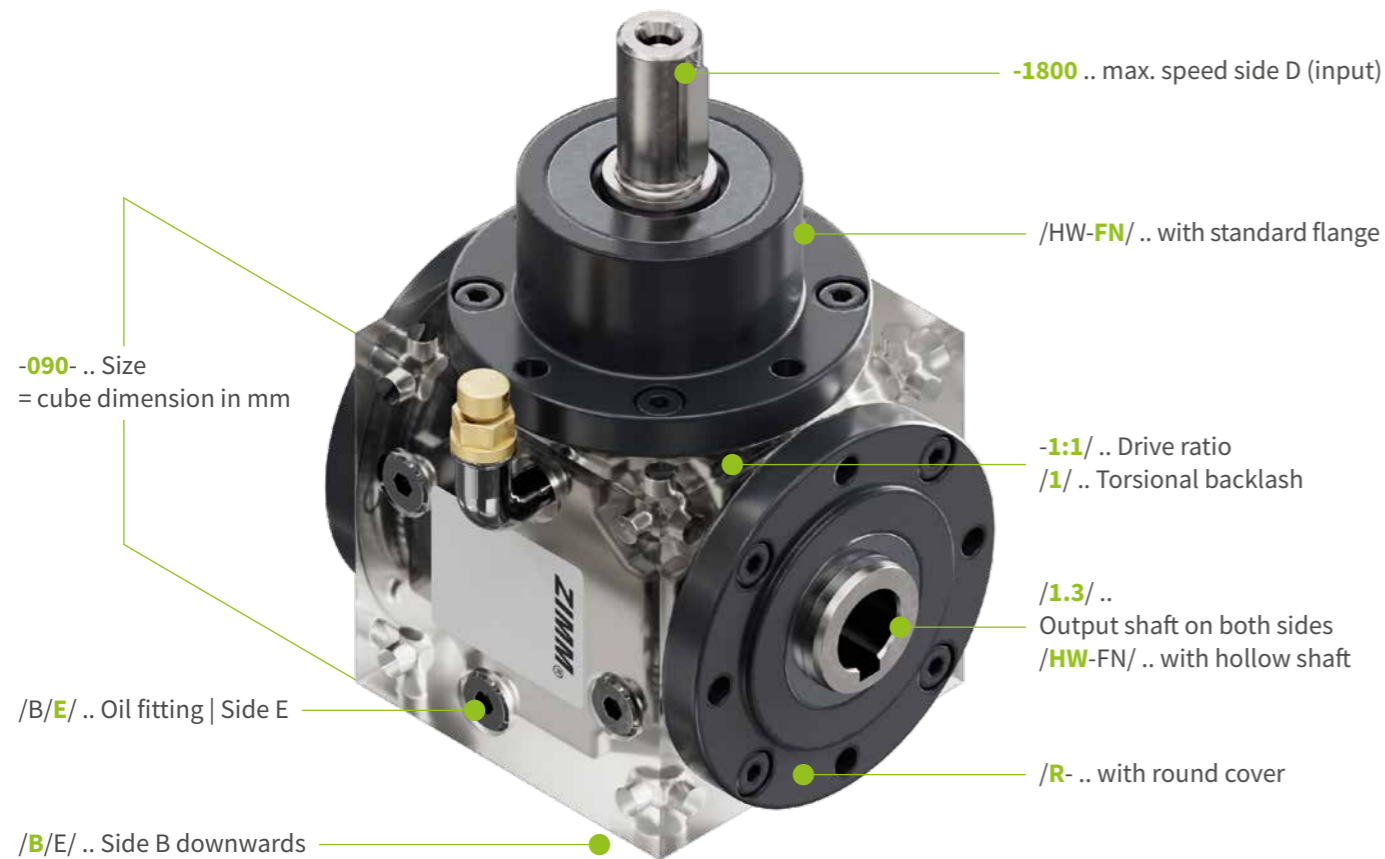

- 1) i = drive shaft : output shaft
- 2) 1 ± 15 arcmin, further on request
- 3) Oil drillings possible on side B, E, F; without oil drillings = .../O
- 4) R... round / Q... square cover
- 5) Shaft D = drive shaft

Technical information

Temperature

- The standard version (with standard lubricant and NBR seals) is designed for operating temperatures up to 80 °C.
- Higher temperatures are possible with high-temperature lubricants and FPM seals.

Contamination

- In case of increased contamination, radial shaft seals in AS version should be used.

Breather

- If a breather is provided, it is supplied loose, including pipe elbow.
- The highest-positioned sealing screw must be replaced by the breather unit before commissioning.

Oil sight glass

- Available from size 090.

Operation and maintenance

Commissioning

- Before commissioning, the direction of rotation must be checked.
- The nameplate is positioned so that the “ZIMM” lettering points towards the bevel gear.
- The first test run should be carried out with as little load as possible.

Lubrication

- A mineral lubricant is used as standard.
- The version is generally lubricated for life.
- In case of increased loads:
 - First lubricant change after 500 operating hours
 - Further changes every 6,000 operating hours
- With a low duty factor, the lubricant should be replaced after approx. 5 years at the latest.

Detailed enquiry?

Our checklists help

If you would like to specify your enquiry in detail, our checklists are available.

You can simply download them as a PDF and then attach them completed to your enquiry.

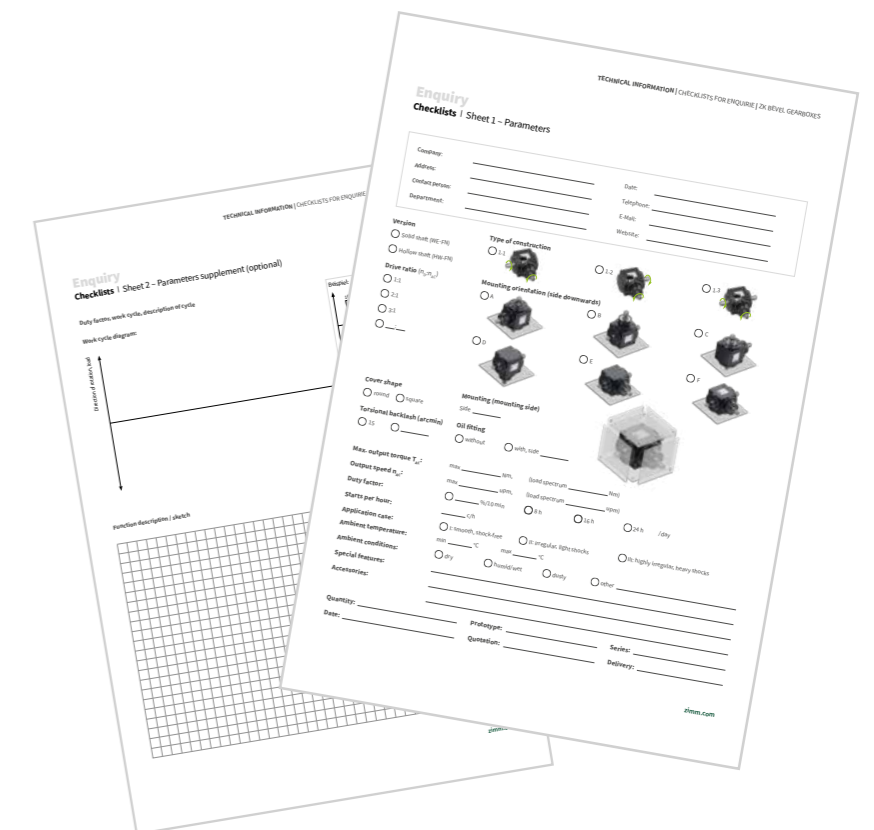

Quick and easy to the complete system

ZIMM modular system

Base element

ZIMM bevel gearboxes – can be flexibly combined with accessories such as connecting shafts, couplings and motors.

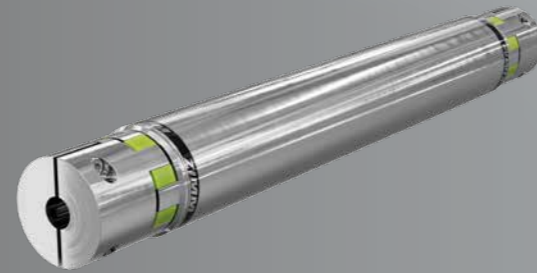

+ Connecting shafts

Transmit the power between gearbox and drive. Split aluminium profiles, radially mountable, precise running and backlash-free.

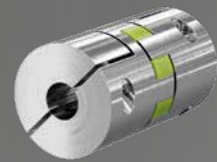

+ Couplings

Elastically couple motor/gearbox to the connecting shaft. Elastomer spider for backlash-free operation and good vibration damping.

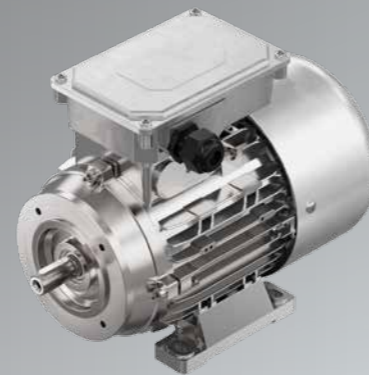

+ Motors

Compact three-phase motors for continuous operation. Can be combined directly with the bevel gearbox via coupling/connector.

Speed, technical know-how and customer focus are at the heart of ZIMM System.

The extended ZIMM modular system fits all gearbox series: the same accessories for bevel gearboxes, screw jacks and actuators – flexibly combinable.



More than a CAD configurator

Configure with guidance. Design in real time.

With the ZIMM Builder, you create complete bevel gearbox and screw jack systems directly in the browser – step by step.

All combinations are checked automatically. Only matching variants are displayed. This produces complete CAD data for your design in the shortest possible time.

From idea to solution – safe and efficient.



Straight to the point

CAD data without detours, without effort

Design with confidence

Plausibility check in real time

Flexible customization

Easily combine sizes and accessories

Better coordination

Share results, speed up approvals

Simply convincing

Clear, reliable and ready to use at any time

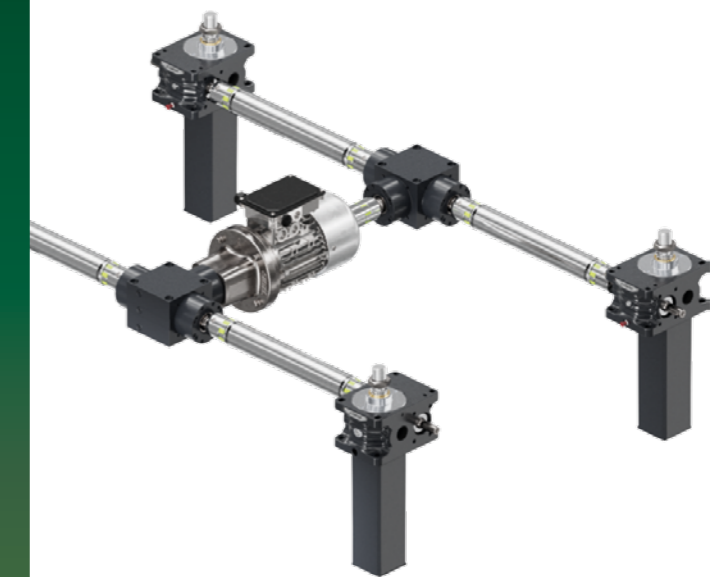

zimm.com/cad
Configure now

ZIMM. When precision matters.

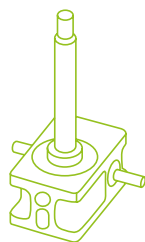

Screw jacks

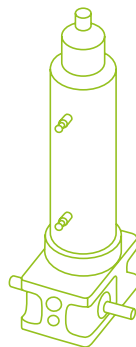

Actuators

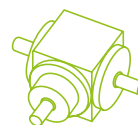

Bevel gearboxes



The drive starts here

ZIMM Group GmbH
Millennium Park 3,
6890 Lustenau/Austria
T +43 5577 806-0, E info@zimm.com
zimm.com



zimm.com/contact
Connect now