

Enquiries

Checklists | Sheet 1 – Parameter

1. max. lifting force in kN

per gearbox _____ kN entire system _____ kN
 in tension _____ kN in compression _____ kN
 Load: static _____ kN dynamic _____ kN

Installation axis

vertical horizontal pivoting

Type of load

smooth impact loads vibration

2. max. lift/travel _____ mm effective working stroke _____ mm

For short stroke applications

(eff. working stroke < gearbox height): regular lubrication stroke: practical not practical

3. Lifting speed

Typ N = 25 mm/s (1,5 m/min) Typ L = 6,25 mm/s (0,375 m/min) _____ mm/s

4. Duty factor, work cycle, description of cycle

_____ strokes per hour _____ strokes per day Hours per day: 8 16 24

i For high duty factors or long strokes, please provide an exact detailed description on the following page

5. Type S „Translating screw“ R „Rotating screw“

6. Version ZE-Screw jack GSZ-Screw jack

7. Motor Three-phase AC motor with brake Manual release _____

8. Operating conditions Dry Humid Dust Chipping _____

Guided movement No guides (no dyn. lateral forces)

Ambient temperature: min. _____ °C max. _____ °C (when < 10 °C and > 40 °C)

i If possible please provide an exact description or sketch on the following page

9. Standard layouts no.: _____ Size: MA1 _____ MA2 _____ MA3 _____ MA4 _____ MA5 _____

see standard layouts, checklists sheets 3 and 4 (for multi-jack systems)

10. Quantity Required _____ Series _____

11. Schedule Quotation _____ Delivery _____

Enquiries

Checklists | Sheet 2 – Parameter (optional)

8a. Purpose / description of the function / ambient conditions (description or sketch)

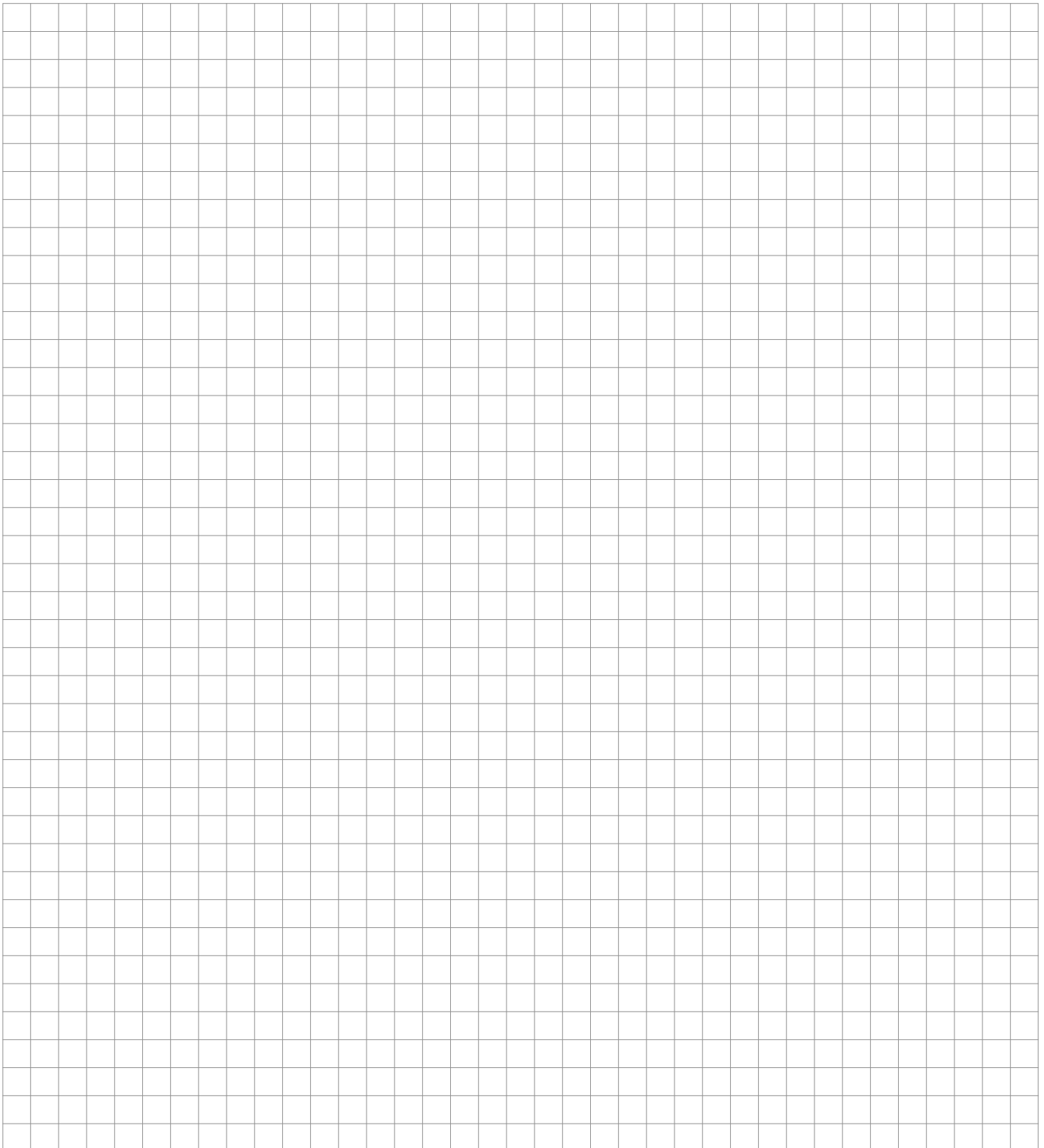
A large grid of graph paper, consisting of 20 columns and 30 rows of small squares, intended for drawing or sketching a technical diagram or function description.

Enquiries

Checklists | Sheet 3 – System layouts

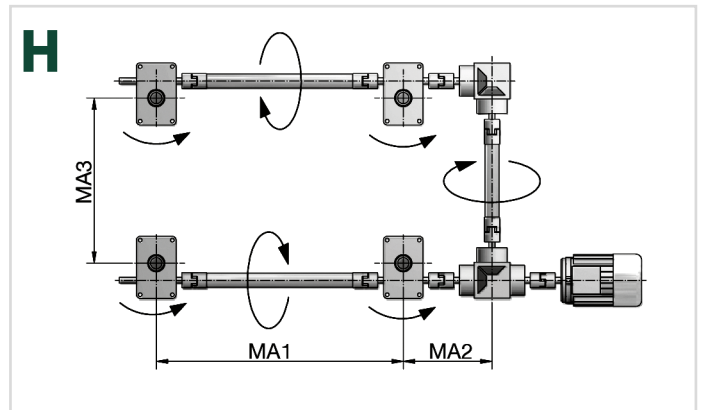
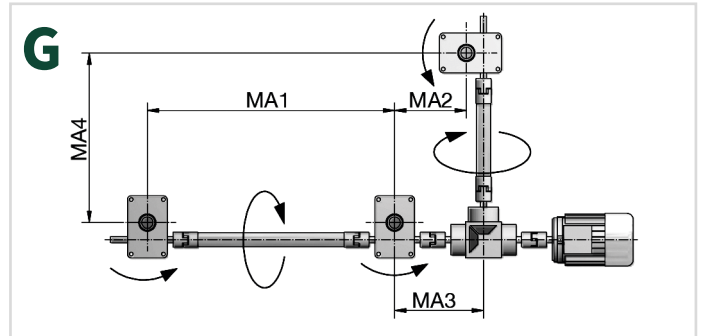
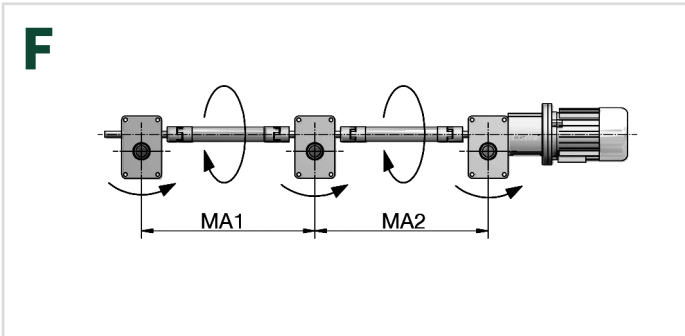
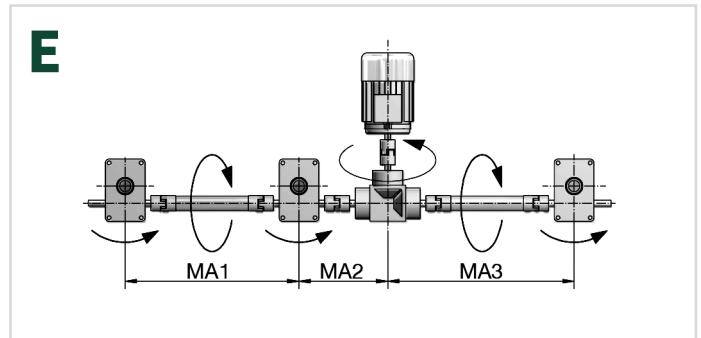
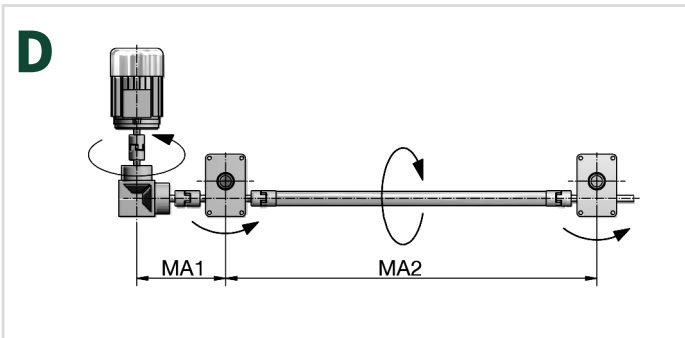
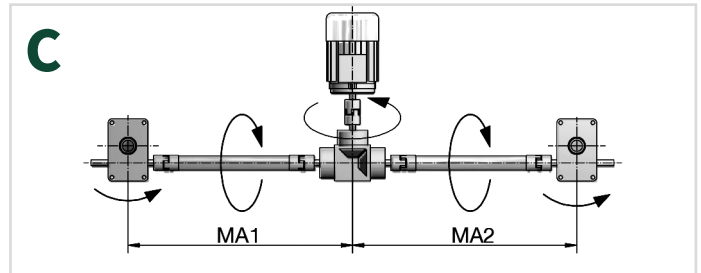
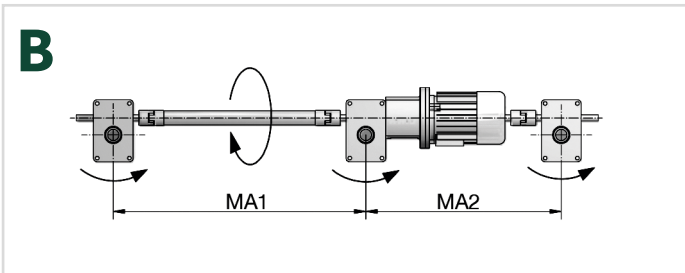
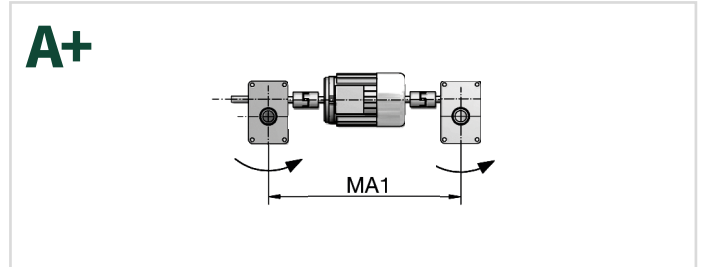
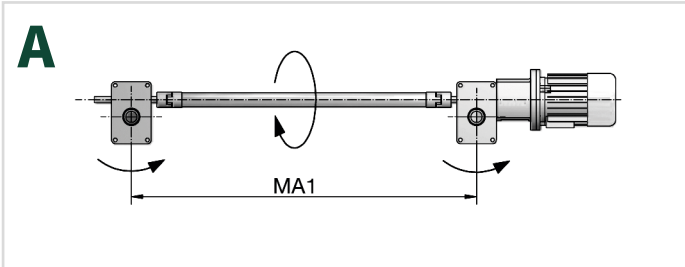

The most common layouts are shown.
If your design is different, be sure to check the direction of rotation.

Enquiries

Checklists | Sheet 4 – System layouts

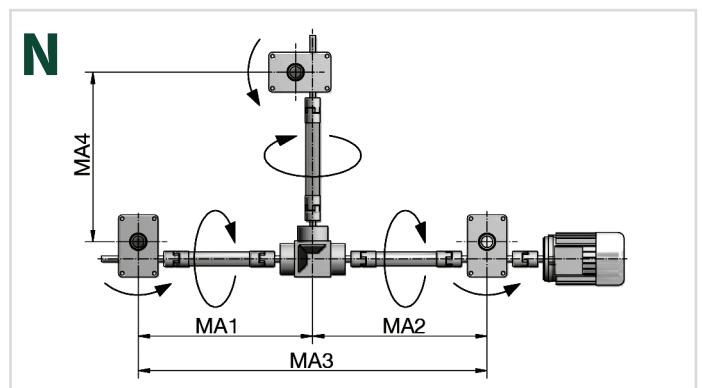
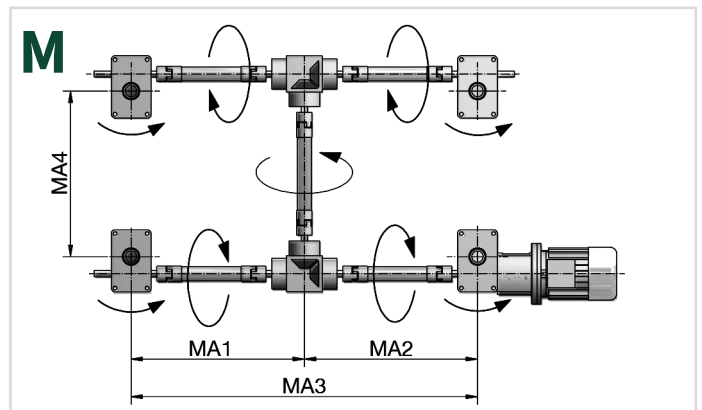
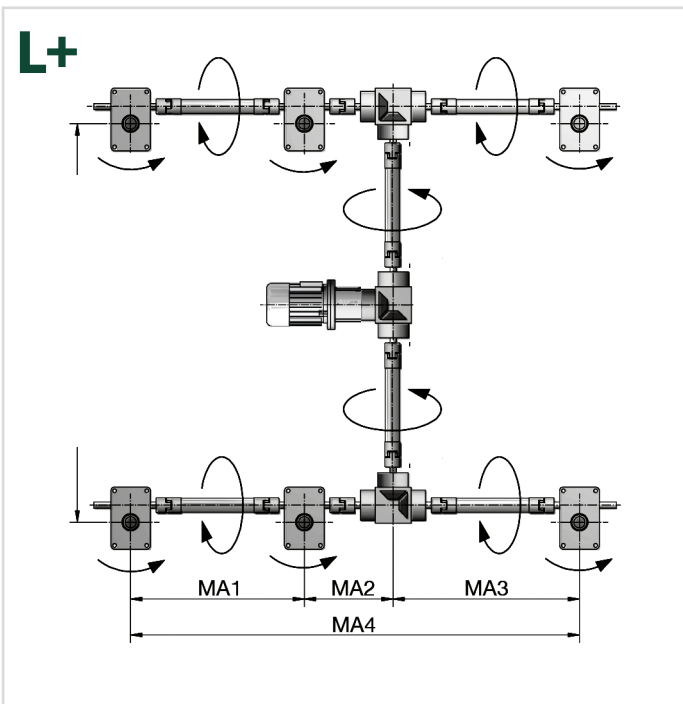
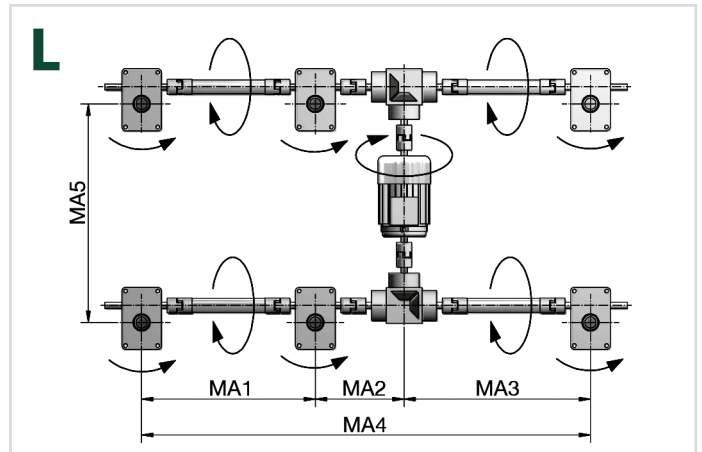
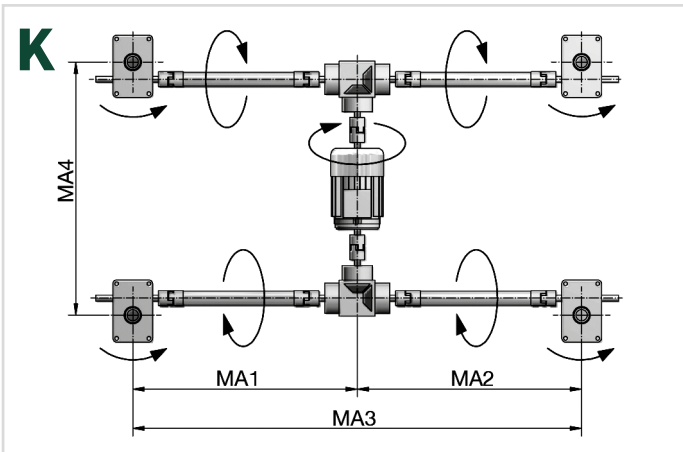
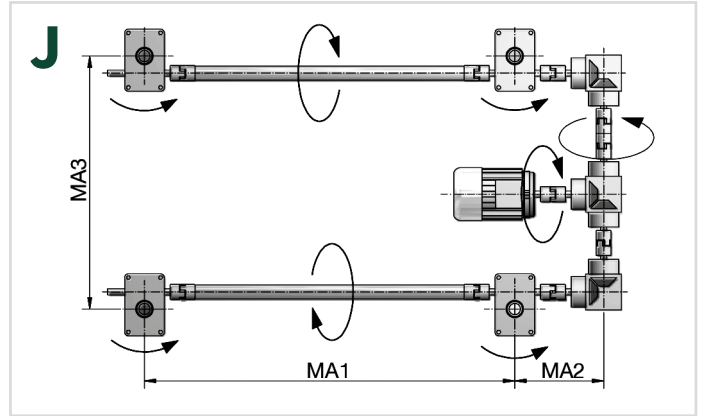
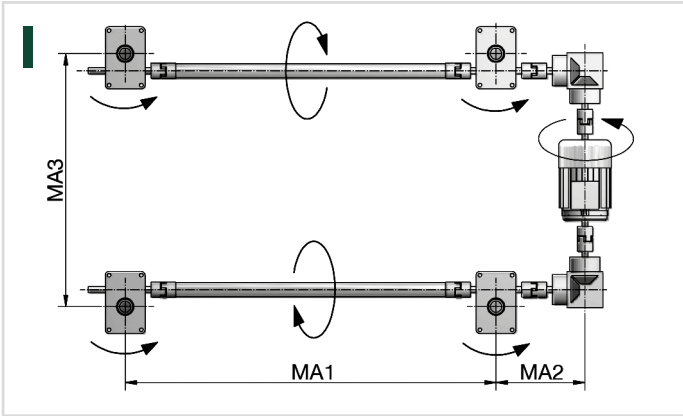

The most common layouts are shown.
If your design is different, be sure to check
the direction of rotation.



Enquiries

Checklists | Sheet 5 – List of components S

Type:

- SN (translating screw, normal)
- SL (translating screw, low speed)

Variant:

- Tr Screw
- SIFA Safety nut
with SIFA monitoring
- KGT Ball screw

Stroke:

_____ mm

- 1. Tension load (kN): static _____
- Tension load (kN): dynamic _____
- 2. Compression load (kN): static _____
- Compression load (kN): dynamic _____

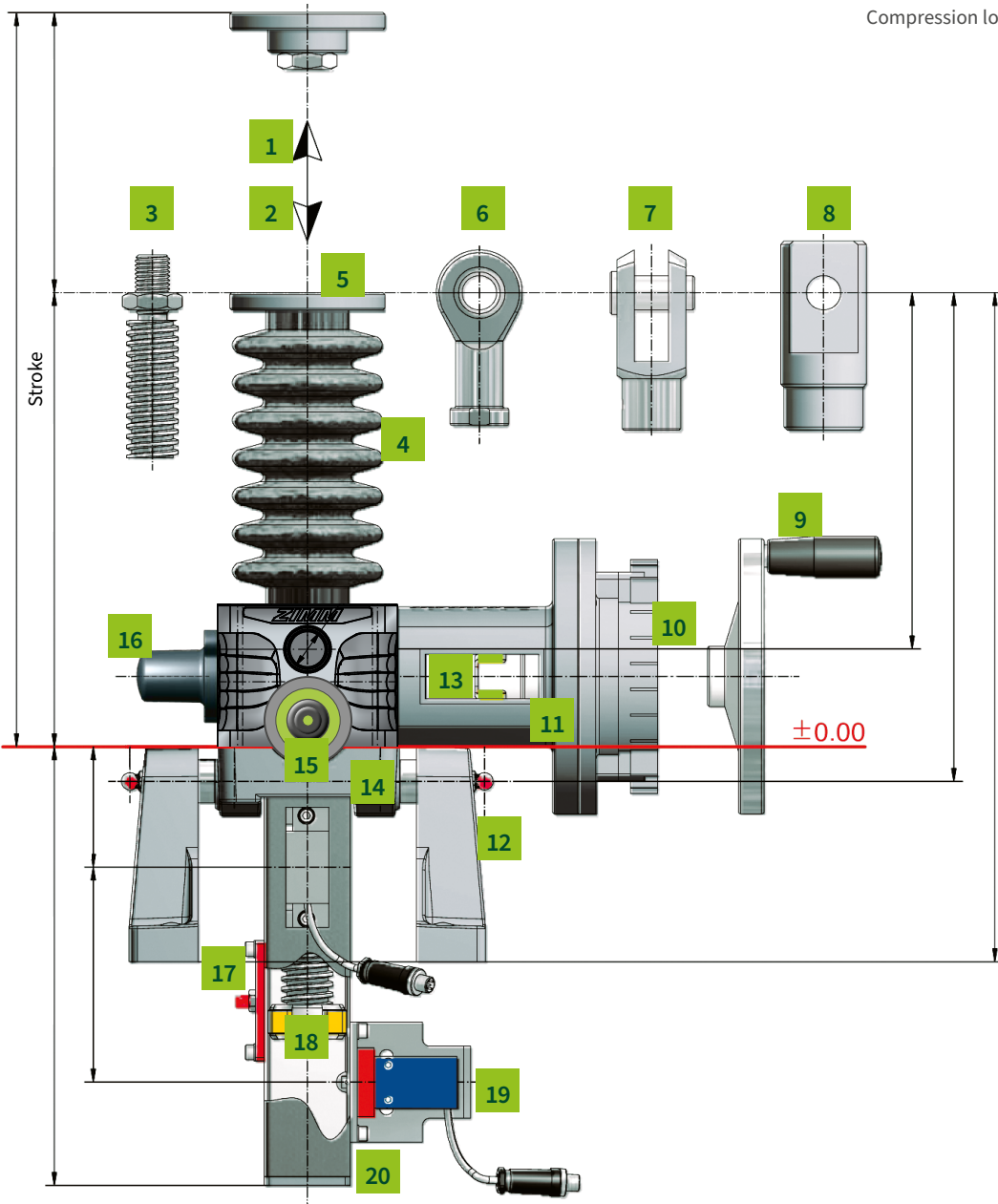

- 3. Standard screw end
- 4. Bellows FB
Spiral spring SF
- 5. Fixing flange BF
- 6. Rod end KGK
- 7. Forked end GK
- 8. Pivot bearing end SLK
- 9. Handwheel HR
Motor with brake
Motor without brake
- 10. Motor with brake
Motor without brake
- 11. Motor flange MF
- 12. Pivot mount LB
- 13. Coupling KUZ
- 14. Pivot bearing plate KAR
- 15. Lubricator Z-LUB
- 16. Protective cap SK
- 17. Lubrication strip SL
- 18. Rotation protection VS
Escape protection AS
- 19. 2x limit switch ES
- 20. Protective tube SRO
Pivoting support tube STRO

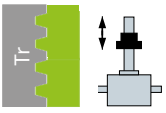

Enquiries

Checklists | Sheet 6 - List of components R

Type:

- RN (rotating screw, normal)
- RL (rotating screw, low speed)

Variant:

- Tr Screw
- SIFA Safety nut
with SIFA monitoring
- KGT Ball screw

Stroke:

_____ mm

- 1. Tension load (kN): static _____
- Tension load (kN): dynamic _____
- 2. Compression load (kN): static _____
- Compression load (kN): dynamic _____

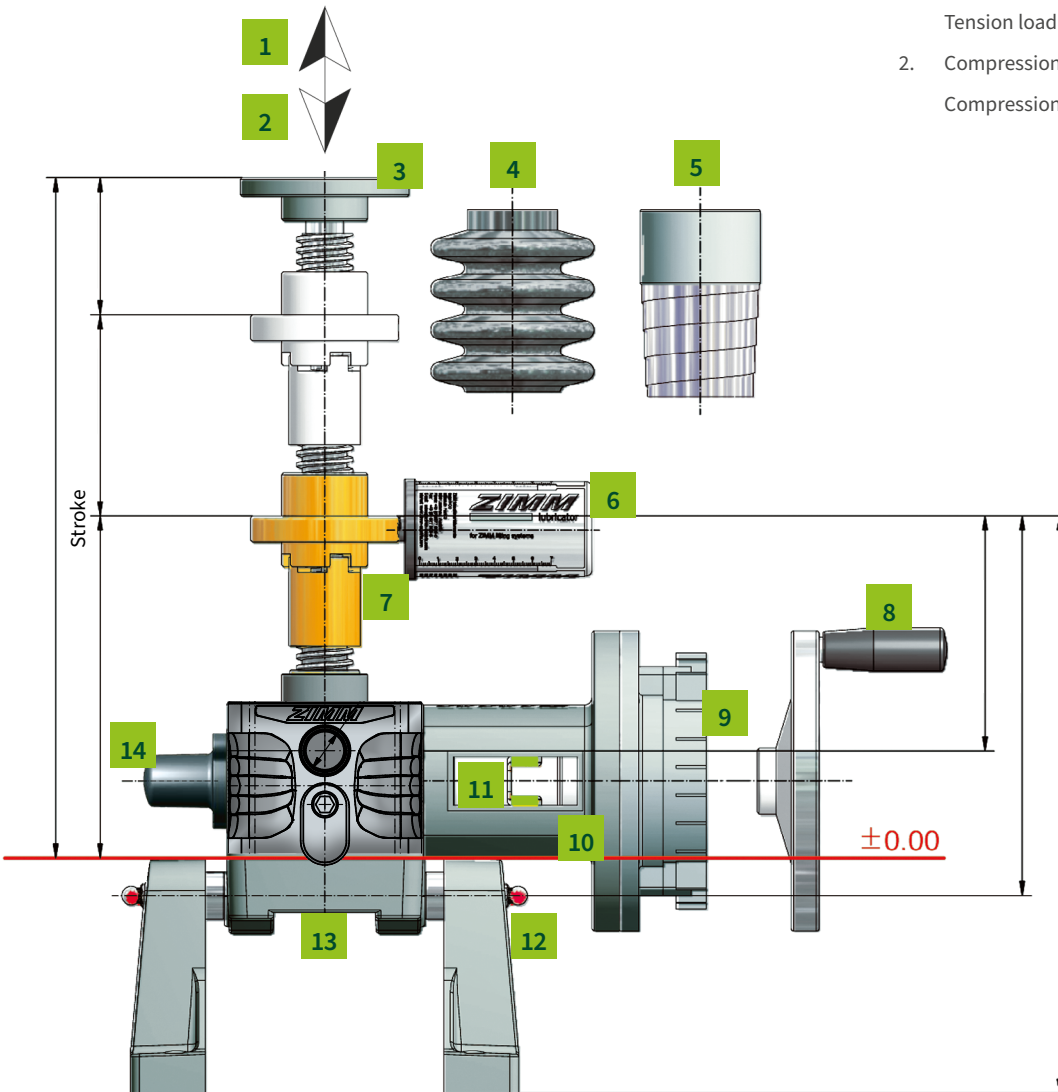

- 3. Opposed bearing plate GLP
- 4. Bellows FB
- 5. Spiral spring cover SF
- 6. Lubricator Z-LUB
- 7. Duplex nut DM
Tr Flange nut FM
Cardan adapter DMA
KGT Flange nut KGT-F
Self-aligning nut PM
Greaseless nut FFDM
Driving flange TRMFL
Safety nut SIFA
Wear monitoring-
SIFA Control
- 8. Handwheel HR
- 9. Motor with brake
Motor without brake
- 10. Motor flange MF
- 11. Coupling KUZ
- 12. Pivot mounts LB
- 13. Pivot bearing plat KAR
- 14. Protective cap SK